

# MOTOROLA SEMICONDUCTOR TECHNICAL DATA

## MC68HC11L6

### Technical Summary 8-Bit Microcontroller

#### Introduction

The design of the MC68HC11L6 high-performance microcontroller (MCU) is based on the MC68HC11E9, including also 16K of ROM, and an additional bidirectional port (port G). The MC68HC11L6 is a high-speed, low-power chip with a multiplexed bus capable of operating at up to 3 MHz. The fully static design allows it to operate at frequencies down to dc.

This summary of technical information is organized into sections, each containing a short description and block diagram of a subsystem and its registers. The bit descriptions included describe only those bits specific to the particular subsystem. For more detailed information on subsystems, programming, and the instruction set, refer to the *M68HC11 Reference Manual*, document number M68HC11 RM/AD.

#### Features

- M68HC11 CPU
- Power-Saving STOP and WAIT Modes
- 16K Bytes of ROM
- 512 Bytes of On-Chip Electrically Erasable PROM (EEPROM) with Block Protect for Extra Security
- 512 Bytes of On-Chip RAM (All Saved During Standby)
- 16-Bit Timer System
  - Four Output Compare Channels
  - Three Input Capture Channels
  - One Input Capture or Output Compare (Software Selectable)
- 8-Bit Pulse Accumulator
- Real-Time Interrupt Circuit
- Computer Operating Properly (COP) Watchdog System
- Synchronous Serial Peripheral Interface (SPI)
- Asynchronous Nonreturn to Zero (NRZ) Serial Communications Interface (SCI)
- Eight-Channel 8-Bit Analog to Digital (A/D) Converter
- 46 General-Purpose I/O Pins
  - 24 Bidirectional Input/Output (I/O) Pins
  - 11 Input-Only and 11 Output-Only Pins
- Available in a 64-Pin Surface Mount Quad Flat Pack or a 68-Pin Plastic Leaded Chip Carrier

#### Ordering Information

Package	Temperature	CONFIG	Description	MC Order Number
PLCC (FN suffix)	-40° to +85° C	\$0F	BUFFALO ROM	MC68HC11L6FN1
QFP (FU Suffix)	-40° to +85° C	\$0F	BUFFALO ROM	MC68HC11L6VFU1

This document contains information on a new product. Specifications and information herein are subject to change without notice.

**MOTOROLA**

# Freescale Semiconductor, Inc.

## Table of Contents

MC68HC11L6.....	1
Features .....	1
Register Index.....	3
64-Pin Quad Flat Pack (QFP) Pin Assignments.....	4
68-Pin Plastic-Leaded Chip Carrier (PLCC) Pin Assignments.....	5
Block Diagram.....	6
Operating Modes and Memory Maps.....	7
Address/Data Demultiplexing .....	7
Memory Maps.....	8
MC68HC11L6 Memory Map .....	8
Registers (Sheet 1 of 2) .....	9
Resets and Interrupts.....	13
Electrically Erasable Programmable Read Only Memory (EEPROM).....	17
Parallel Input/Output.....	20
Parallel I/O Handshake .....	20
Parallel I/O Control .....	22
Serial Communications Interface (SCI).....	26
SCI Baud Rate.....	29
Serial Peripheral Interface (SPI).....	33
SPI Transfer Format .....	35
Timer Summary.....	37
Main Timer.....	38
Timer Control Configuration.....	41
Real-Time Interrupt Rates.....	44
Pulse Accumulator.....	45
Pulse Accumulator System Block Diagram.....	45
Pulse Accumulator Timing.....	45
A/D Converter Block Diagram.....	48
A/D Conversion Sequence .....	49
Electrical Model of an Analog Input Pin (Sample Mode).....	49
A/D Converter Channel Assignments.....	50
Analog Input to 8-Bit Result Translation Table.....	51

# Freescale Semiconductor, Inc.

## Register Index

Register		Address	Page
ADCTL	A/D Control/Status	\$1030	50
ADR1-ADR4	A/D Results	\$1031-\$1034	51
BAUD	Baud Rate	\$102B	28
BPROT	Block Protect	\$1035	17
CFORC	Timer Compare Force	\$100B	39
CONFIG	EEPROM, ROM, COP Enables	\$103F	13, 19
COPRST	Arm/Reset COP Timer Circuitry	\$103A	15
DDRC	Data Direction for Port C	\$1007	23
DDRD	Data Direction for Port D	\$1009	24, 34
DDRG	Data Direction for Port G	\$1037	25
HPRIO	Highest Priority I-Bit Interrupt and Miscellaneous	\$103C	16
INIT	RAM and I/O Mapping	\$103D	12
OC1D	Output Compare 1 Data	\$100D	39
OC1M	Output Compare 1 Mask	\$100C	39
OPTION	System Configuration Options	\$1039	15, 18, 51
PACNT	Pulse Accumulator Counter	\$1027	47
PACTL	Pulse Accumulator Control	\$1026	24, 43, 47
PIOC	Parallel I/O Control	\$1002	21
PORTA	Port A Data	\$1000	21
PORTB	Port B Data	\$1004	23
PORTC	Port C Data	\$1003	22
PORTCL	Port C Latched	\$1005	23
PORTD	Port D Data	\$1008	23
PORTE	Port E Data	\$100A	24
PORTG	Port G Data	\$1036	25
PPROG	EEPROM Programming Control	\$103B	18
SCCR1	SCI Control 1	\$102C	30
SCCR2	SCI Control 2	\$102D	30
SCDR	SCI Data	\$102F	32
SCSR	SCI Status	\$102E	31
SPCR	Serial Peripheral Control	\$1028	28, 34
SPDR	SPI Data	\$102A	36
SPSR	Serial Peripheral Status	\$1029	35
TCNT	Timer Counter	\$100E, \$100F	39
TCTL2	Timer Control 2	\$1021	41
TEST1	Factory Test	\$103E	12
TFLG1	Timer Interrupt Flag 1	\$1023	42
TFLG2	Timer Interrupt Flag 2	\$1025	43, 46
TI4O5	Timer Input Capture 4/Output Compare 5	\$101E, \$101F	40
TMSK1	Timer Interrupt Mask 1	\$1022	41
TMSK2	Timer Interrupt Mask 2	\$1024	42, 46
TOC1-TOC4	Timer Output Compare	\$1016-\$101D	40

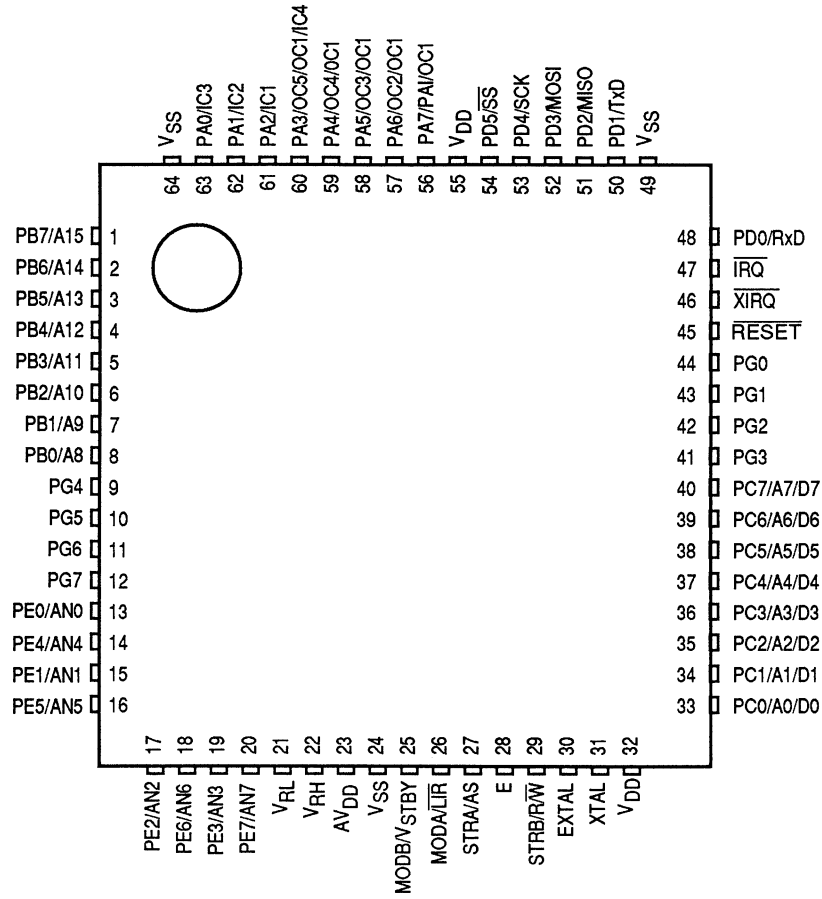

64-Pin Quad Flat Pack (QFP) Pin Assignments

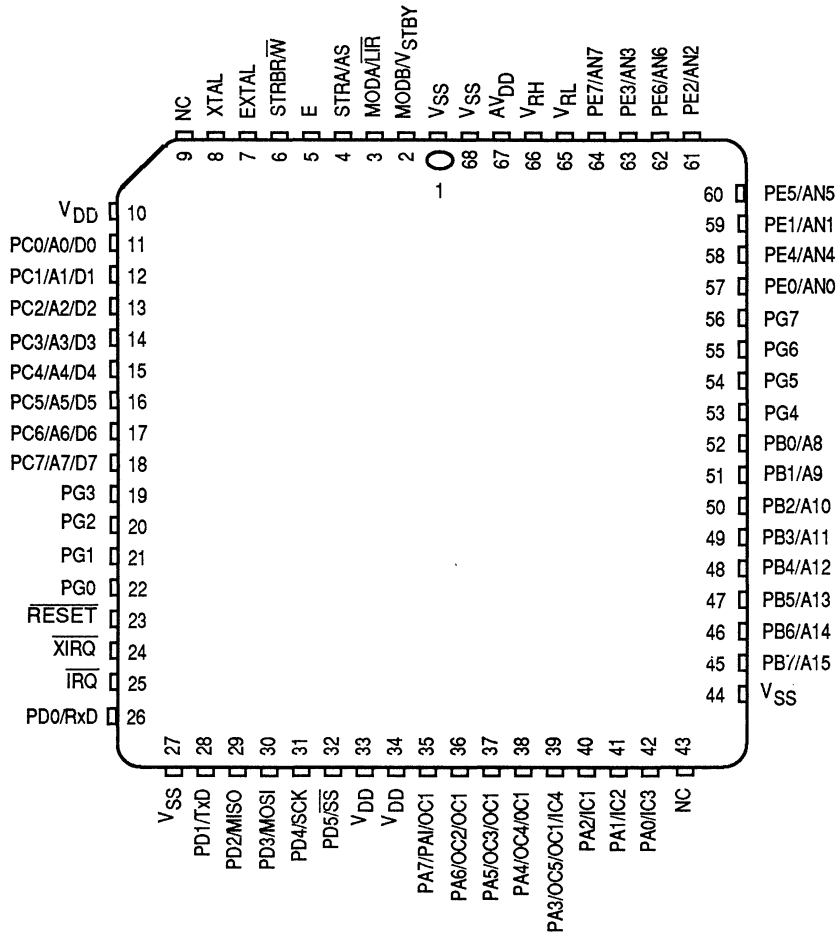

68-Pin Plastic-Leaded Chip Carrier (PLCC) Pin Assignments

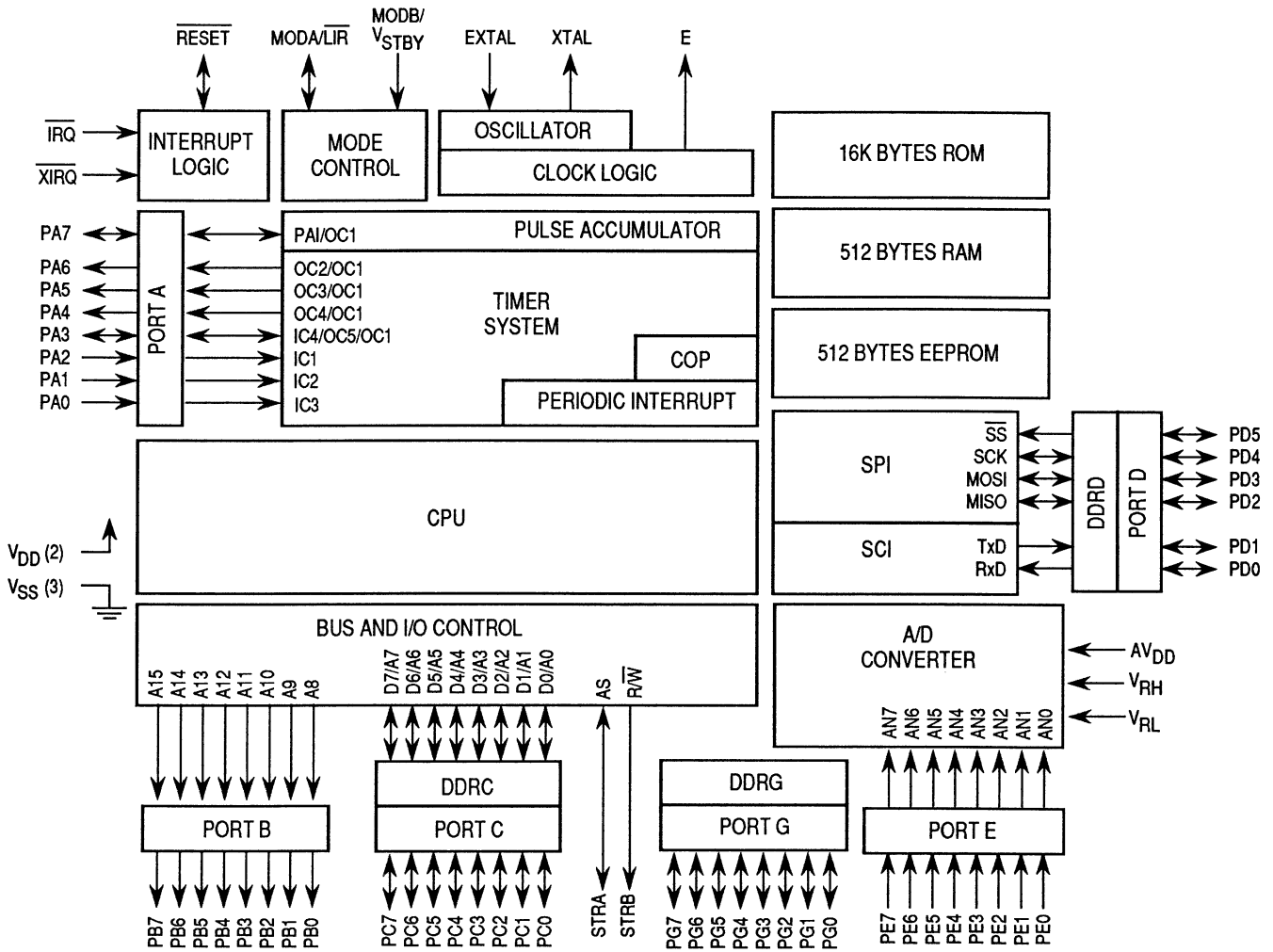

Block Diagram

## Operating Modes and Memory Maps

In single-chip operating mode, the MC68HC11L6 is a monolithic microcontroller without external address or data buses.

In expanded multiplexed operating mode, the MCU can access a 64K-byte address space. The space includes the same on-chip memory addresses used for single chip mode, in addition to external peripheral and memory devices. The expansion bus is made up of ports B and C, and control signals AS and R/W. The address, R/W, and AS signals are active and valid for all bus cycles, including accesses to internal memory locations. The following figure demonstrates a recommended method of demultiplexing low order addresses from data at port C.

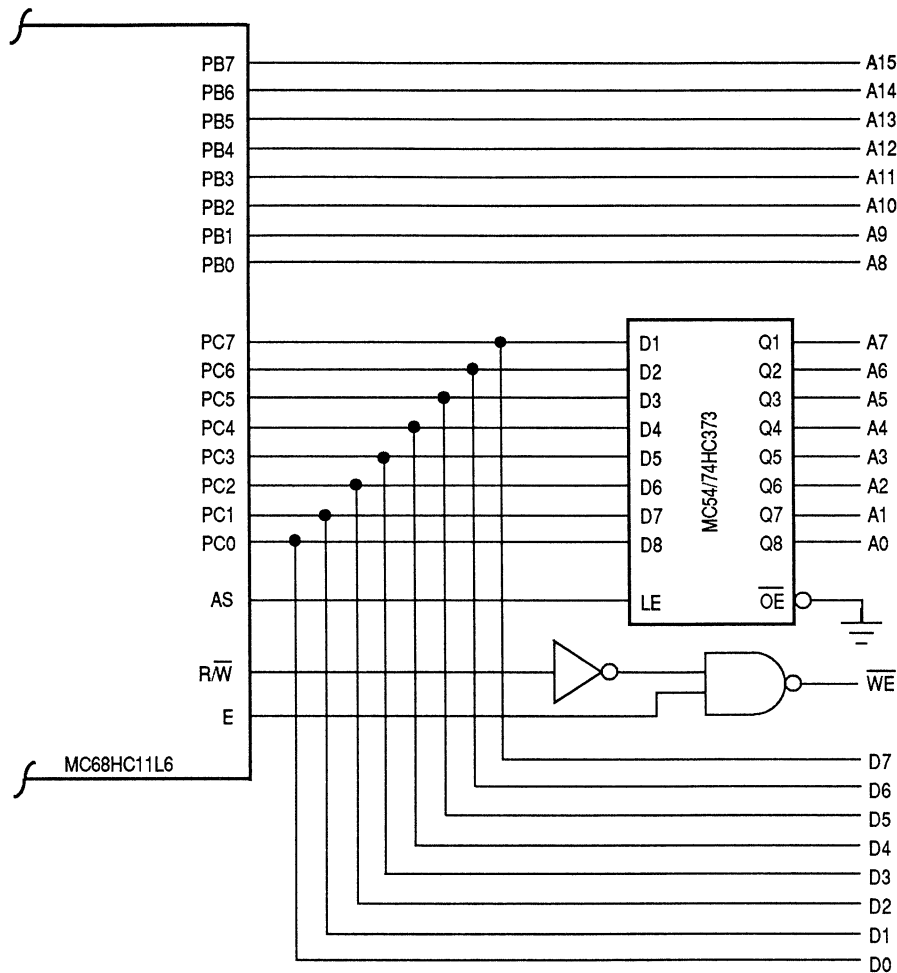

**Address/Data Demultiplexing**

The special bootstrap mode allows unlimited special purpose programs to be entered into internal RAM. The boot loader program uses the SCI to read a program of up to 512 bytes into on-chip RAM at \$0000 through \$01FF. After a four-character delay, or receiving the character for address \$01FF, control passes to the loaded program at \$0000.

Special test mode is used primarily for factory testing.

# Freescale Semiconductor, Inc.

## Memory Maps

Memory locations are the same for expanded multiplexed and single-chip modes. The 64-byte register block originates at \$1000 after reset and can be placed at any other 4K boundary (\$x000) after reset by writing an appropriate value to the INIT register. The on-board 512-byte RAM is located at \$0000 after reset and can be placed at any other 4K boundary (\$x000) by writing an appropriate value to the INIT register. The 512-byte EEPROM is located at \$B600 through \$B7FF after reset, if it is enabled. The 16K-byte ROM is located at \$C000 through \$FFFF, if it is enabled.

Hardware priority is built into the memory remapping. Registers have priority over RAM, and RAM has priority over ROM. The higher priority resource covers the lower, making the underlying locations inaccessible.

In special bootstrap mode, a bootloader ROM is enabled at locations \$BF40 through \$BFFF.

In special test mode and special bootstrap mode, reset and interrupt vectors are located at \$BFC0 through \$BFFF.

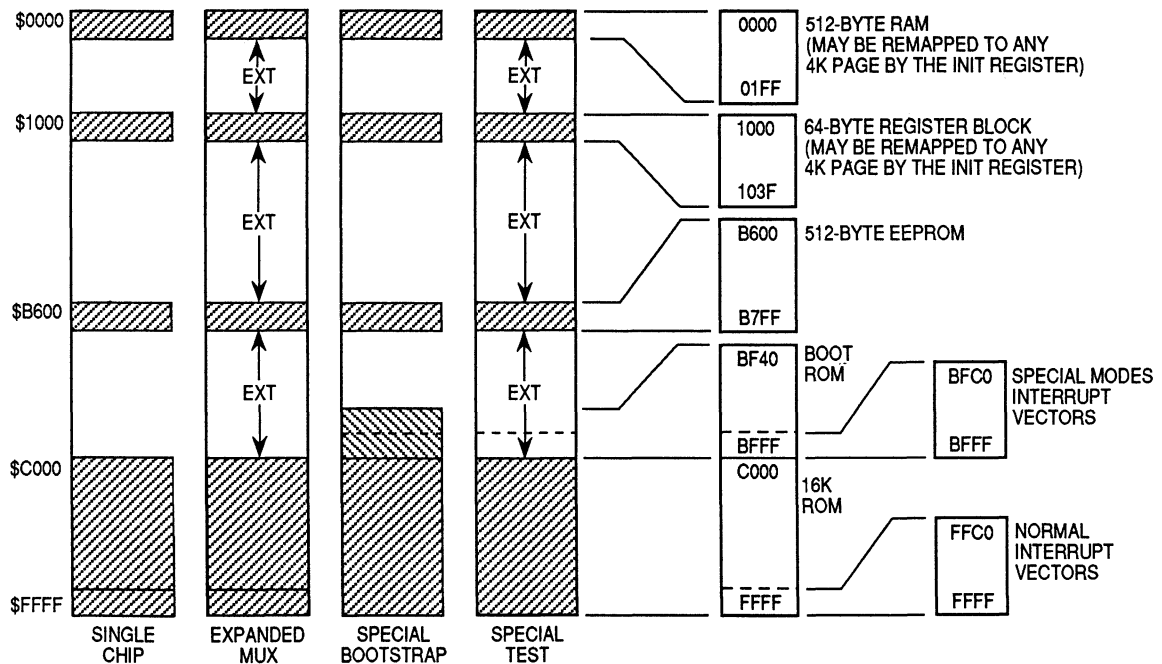

MC68HC11L6 Memory Map

# Freescale Semiconductor, Inc.

## Registers (Sheet 1 of 2)

(The register block can be remapped to any 4K boundary)

	Bit 7	6	5	4	3	2	1	Bit 0	
\$1000	PA7	PA6	PA5	PA4	PA3	PA2	PA1	PA0	PORTA
\$1001									Reserved
\$1002	STAF	STAI	CWOM	HNDS	OIN	PLS	EGA	INVB	PIOC
\$1003	PC7	PC6	PC5	PC4	PC3	PC2	PC1	PC0	PORTC
\$1004	PB7	PB6	PB5	PB4	PB3	PB2	PB1	PB0	PORTB
\$1005	PCL7	PCL6	PCL5	PCL4	PCL3	PCL2	PCL1	PCL0	PORTCL
\$1006									Reserved
\$1007	DDC7	DDC6	DDC5	DDC4	DDC3	DDC2	DDC1	DDC0	DDRC
\$1008	0	0	PD5	PD4	PD3	PD2	PD1	PD0	PORTD
\$1009	0	0	DDD5	DDD4	DDD3	DDD2	DDD1	DDD0	DDRD
\$100A	PE7	PE6	PE5	PE4	PE3	PE2	PE1	PE0	PORTE
\$100B	FOC1	FOC2	FOC3	FOC4	FOC5	0	0	0	CFORC
\$100C	OC1M7	OC1M6	OC1M5	OC1M4	OC1M3	0	0	0	OC1M
\$100D	OC1D7	OC1D6	OC1D5	OC1D4	OC1D3	0	0	0	OC1D
\$100E	Bit 15	14	13	12	11	10	9	Bit 8	TCNT (High)
\$100F	Bit 7	6	5	4	3	2	1	Bit 0	TCNT (Low)
\$1010	Bit 15	14	13	12	11	10	9	Bit 8	TIC1 (High)
\$1011	Bit 7	6	5	4	3	2	1	Bit 0	TIC1 (Low)
\$1012	Bit 15	14	13	12	11	10	9	Bit 8	TIC2 (High)
\$1013	Bit 7	6	5	4	3	2	1	Bit 0	TIC2 (Low)
\$1014	Bit 15	14	13	12	11	10	9	Bit 8	TIC3 (High)
\$1015	Bit 7	6	5	4	3	2	1	Bit 0	TIC3 (Low)
\$1016	Bit 15	14	13	12	11	10	9	Bit 8	TOC1 (High)
\$1017	Bit 7	6	5	4	3	2	1	Bit 0	TOC1 (Low)
\$1018	Bit 15	14	13	12	11	10	9	Bit 8	TOC2 (High)
\$1019	Bit 7	6	5	4	3	2	1	Bit 0	TOC2 (Low)
\$101A	Bit 15	14	13	12	11	10	9	Bit 8	TOC3 (High)
\$101B	Bit 7	6	5	4	3	2	1	Bit 0	TOC3 (Low)
\$101C	Bit 15	14	13	12	11	10	9	Bit 8	TOC4 (High)
\$101D	Bit 7	6	5	4	3	2	1	Bit 0	TOC4 (Low)
\$101E	Bit 15	14	13	12	11	10	9	Bit 8	TI4O5 (High)
\$101F	Bit 7	6	5	4	3	2	1	Bit 0	TI4O5 (Low)
\$1020	OM2	OL2	OM3	OL3	OM4	OL4	OM5	OL5	TCTL1

# Freescale Semiconductor, Inc.

## MC68HC11L6 Registers (Sheet 2 of 2)

	Bit 7	6	5	4	3	2	1	Bit 0	
\$1021	EDG4B	EDG4A	EDG1B	EDG1A	EDG2B	EDG2A	EDG3B	EDG3A	TCTL2
\$1022	OC1I	OC2I	OC3I	OC4I	I4O5I	IC1I	IC2I	IC3I	TMSK1
\$1023	OC1F	OC2F	OC3F	OC4F	I4O5F	IC1F	IC2F	IC3F	TFLG1
\$1024	TOI	RTII	PAOVI	PAII	0	0	PR1	PR0	TMSK2
\$1025	TOF	RTIF	PAOVF	PAIF	0	0	0	0	TFLG2
\$1026	DDRA7	PAEN	PAMOD	PEDGE	DDRA3	I4/O5	RTR1	RTR0	PACTL
\$1027	Bit 7	6	5	4	3	2	1	Bit 0	PACNT
\$1028	SPIE	SPE	DWOM	MSTR	CPOL	CPHA	SPR1	SPR0	SPCR
\$1029	SPIF	WCOL	0	MODF	0	0	0	Bit 0	SPSR
\$102A	Bit 7	6	5	4	3	2	1	Bit 0	SPDR
\$102B	TCLR	0	SCP1	SCP0	RCKB	SCR2	SCR1	SCR0	BAUD
\$102C	R8	T8	0	M	WAKE	0	0	0	SCCR1
\$102D	TIE	TCIE	RIE	ILIE	TE	RE	RWU	SBK	SCCR2
\$102E	TDRE	TC	RDRF	IDLE	OR	NF	FE	0	SCSR
\$102F	R7/T7	R6/T6	R5/T5	R4/T4	R3/T3	R2/T2	R1/T1	R0/T0	SCDR
\$1030	CCF	0	SCAN	MULT	OD	CC	CB	CA	ADCTL
\$1031	Bit 7	6	5	4	3	2	1	Bit 0	ADR1
\$1032	Bit 7	6	5	4	3	2	1	Bit 0	ADR2
\$1033	Bit 7	6	5	4	3	2	1	Bit 0	ADR3
\$1034	Bit 7	6	5	4	3	2	1	Bit 0	ADR4
\$1035	0	0	0	PTCON	BPRT3	BPRT2	BPRT1	BPRT0	BPROT
\$1036	PG7	PG6	PG5	PG4	PG3	PG2	PG1	PG0	PORTG
\$1037	DDG7	DDG6	DDG5	DDG4	DDG3	DDG2	DDG1	DDG0	DDRG
\$1038									Reserved
\$1039	ADPU	CSEL	IRQE	DLY	CME	0	CR1	CR0	OPTION
\$103A	Bit 7	6	5	4	3	2	1	Bit 0	COPRST
\$103B	ODD	EVEN	0	BYTE	ROW	ERASE	EELAT	EPPGM	PPROG
\$103C	RBOOT	SMOD	MDA	IRVNE	PSEL3	PSEL2	PSEL1	PSEL0	HPRIO
\$103D	RAM3	RAM2	RAM1	RAM0	REG3	REG2	REG1	REG0	INIT
\$103E	TILOP	0	OCCR	CBYP	DISR	FCM	FCOP	TCON	TEST1
\$103F	0	0	0	0	NOSEC	NOCOP	ROMON	EEON	CONFIG

**HPRIO** — Highest Priority I-Bit Interrupt and Miscellaneous

**\$103C**

	Bit 7	6	5	4	3	2	1	Bit 0
	RBOOT	SMOD	MDA	IRVNE	PSEL3	PSEL2	PSEL1	PSEL0
RESET:	—	—	—	—	0	1	0	1

RBOOT, SMOD, and MDA reset are dependant upon the state of the power-up initialization mode and can only be written in special modes.

**RBOOT** — Read Bootstrap ROM

Writable only when SMOD = 1.

0 = Bootloader ROM disabled and not in map

1 = Boot loader ROM enabled and in map at \$BF40–\$BFFF

**SMOD, MDA** — Special Mode Select, Mode Select A

Inputs		Mode	Latched at Reset		
MODB	MODA		RBOOT	SMOD	MDA
1	0	Single Chip	0	0	0
1	1	Expanded Multiplexed	0	0	1
0	0	Special Bootstrap	1	1	0
0	1	Special Test	0	1	1

**IRVNE** — Internal Read Visibility/Not E (IRVNE can be written once in any mode.)

In expanded modes, IRVNE determines whether IRV is on or off.

In special test mode, IRVNE is reset to 1 and in all other modes IRVNE is reset to 0.

0 = No internal read visibility on external bus

1 = Data from internal reads is driven out the external data bus.

In single chip modes this bit determines whether the E clock drives out of the chip.

0 = E is driven out from the chip

1 = E pin is driven low

Mode	IRVNE Out of Reset	E Clock Out of Reset	IRV Out of Reset	IRVNE Affects Only
Single Chip	0	On	Off	E
Expanded	0	On	Off	IRV
Boot	0	On	Off	E
Special Test	1	On	On	IRV

**PSEL3–PSEL0** — Priority Select Bits 3–0 (Refer to **Resets and Interrupts.**)

## INIT — RAM and I/O Mapping

**\$103D**

	Bit 7	6	5	4	3	2	1	Bit 0
	RAM3	RAM2	RAM1	RAM0	REG3	REG4	REG1	REG0
RESET:	0	0	0	0	0	0	0	1

### RAM3–RAM0 — Internal 512-Byte RAM Map Position

RAM3–RAM0 determine the upper four bits of the RAM address, positioning RAM at selected 4K boundary.

### REG3–REG0 — 64-Byte Register Block Map Position

REG3–REG0 determine the upper four bits of the REG address, positioning REG at selected 4K boundary.

### NOTE

Can be written only once in first 64 cycles out of reset in normal modes or at any time in special modes. For more information, refer to the text that accompanies the memory map .

## TEST1 — Factory Test

**\$103E**

	Bit 7	6	5	4	3	2	1	Bit 0
	TILOP	0	OCCR	CBYP	DISR	FCM	FCOP	TCON
RESET:	0	0	0	0	—	0	0	0

TEST1 bits are writable in test and bootstrap modes only.

TILOP — Test Illegal Opcode (TEST)

OCCR — Output Condition Code Register to Timer Port (TEST)

CBYP — Timer Divider Chain Bypass (TEST)

DISR — Disable Resets from COP and Clock Monitor (TEST)

DISR is forced to reset out of reset in special test and bootstrap modes.

FCM — Force Clock Monitor Failure (TEST)

FCOP — Force COP Watchdog Failure (TEST)

TCON — Test Configuration Register (TEST)

CONFIG — EEPROM, ROM, COP Enables

\$103F

	Bit 7	6	5	4	3	2	1	Bit 0
	0	0	0	0	NOSEC	NOCOP	ROMON	EEON
RESET:	0	0	0	0	—	—	—	—

NOSEC — EEPROM Security Disable (Refer to **EEPROM** section.)

NOCOP — COP System Disable (Refer to **Resets and Interrupts**.)

ROMON — ROM Enable

In single chip mode ROMON is forced to one out of reset.

- 0 = 16K ROM removed from the memory map
- 1 = 16K ROM present in the memory map

EEON — EEPROM Enable

- 0 = EEPROM is removed from the memory map
- 1 = EEPROM is present in the memory map

**Resets and Interrupts**

The MC68HC11L6 has 3 reset vectors and 18 interrupt vectors. The reset vectors are:

- $\overline{\text{RESET}}$ , or Power-On
- COP Clock Monitor Fail
- COP Failure

The 18 interrupt vectors service 23 interrupt sources (3 non-maskable, 20 maskable). The 3 non-maskable interrupt vectors are:

- Illegal Opcode Trap
- Software Interrupt
- XIRQ Pin (Pseudo Non-Maskable Interrupt)

The 20 interrupt sources are subject to masking by a global interrupt mask, the I-bit in the CCR. In addition to the global I bit, all of these sources, except the external interrupt ( $\overline{\text{IRQ}}$ ), are subject to local enable bits in control registers. Most interrupt sources in the M68HC11 have separate interrupt vectors, therefore there is usually no need for software to poll control registers to determine the cause of an interrupt. The maskable interrupt sources respond to a fixed-priority relationship, except that any one source can be dynamically elevated to the highest priority position of any maskable source. The following table contains a list of interrupt and reset vector assignments.

On-chip peripheral systems generate maskable interrupts, which are recognized only if the global interrupt mask bit (I) in the condition code register (CCR) is clear. Maskable interrupts are

## Freescale Semiconductor, Inc.

prioritized according to a default arrangement, but any one source can be elevated to the highest maskable priority position by the HPRIO register. The HPRIO register can be written at any time, provided the I-bit in the CCR is set.

### Interrupt and Reset Vector Assignments

Vector Address	Interrupt Source	CC Register Mask	Local Mask
FFC0, C1–FFD4, D5	Reserved	—	—
FFD6, D7	SCI Serial System	I-Bit	
	• SCI Transmit Complete		TCIE
	• SCI Transmit Data Register Empty		TIE
	• SCI Idle Line Detect		ILIE
	• SCI Receiver Overrun		RIE
	• SCI Receive Data Register Full		RIE
FFD8, D9	SPI Serial Transfer Complete	I-Bit	SPIE
FFDA, DB	Pulse Accumulator Input Edge	I-Bit	PAII
FFDC, DD	Pulse Accumulator Overflow	I-Bit	PAOVI
FFDE, DF	Timer Overflow	I-Bit	TOI
FFE0, E1	Timer Input Capture 4/ Output Compare 5	I-Bit	I4O5I
FFE3, E2	Timer Output Compare 4	I-Bit	OC4I
FFE4, E5	Timer Output Compare 3	I-Bit	OC3I
FFE6, E7	Timer Output Compare 2	I-Bit	OC2I
FFE8, E9	Timer Output Compare 1	I-Bit	OC1I
FFEA, EB	Timer Input Capture 3	I-Bit	IC3
FFEC, ED	Timer Input Capture 2	I-Bit	IC2I
FFEE, EF	Timer Input Capture 1	I-Bit	IC1I
FFF0, F1	Real-Time Interrupt	I-Bit	RTII
FFF2, F3	Parallel I/O Handshake	I-Bit	STAI
	$\overline{\text{IRQ}}$ (External Pin)		None
FFF4, F5	$\overline{\text{XIRQ}}$ Pin	I-Bit	None
FFF6, F7	Software Interrupt	None	None
FFF8, F9	Illegal Opcode Trap	None	None
FFFA, FB	COP Failure	None	NOCOP
FFFC, FD	COP Clock Monitor Fail	None	CME
FFFE, FF	$\overline{\text{RESET}}$	None	None

For some interrupt sources, such as the parallel I/O interrupt and the SCI interrupts, the flags are automatically cleared during the normal course of responding to the interrupt requests. For example, the RDRF flag in the SCI system is cleared by an automatic clearing mechanism consisting of a read of the SCI status register while RDRF is set, followed by a read of the SCI data register. The usual response to an RDRF interrupt request is to read the SCI status register to check for receive errors, then to read the received data from the SCI data register. These two steps satisfy the automatic clearing mechanism without requiring any special instructions.

**OPTION — System Configuration Options**

**\$1039**

	Bit 7	6	5	4	3	2	1	Bit 0
	ADPU	CSEL	IRQE*	DLY*	CME	0	CR1*	CR0*
RESET:	0	0	0	1	0	0	0	0

\* Can be written only once in first 64 cycles out of reset in normal modes or at any time in special modes.

**ADPU — A/D Power-Up** (Refer to **A/D Converter**.)

**CSEL — Clock Select** (Refer to **A/D Converter**, or **EEPROM** sections.)

**IRQE —  $\overline{\text{IRQ}}$  Select Edge Sensitive Only**

0 = Low level recognition

1 = Falling edge recognition

**DLY — Enable Oscillator Start-Up Delay on Exit from STOP**

0 = No stabilization delay on exit from STOP

1 = Stabilization delay enabled on exit from STOP

**CME — Clock Monitor Enable**

0 = Clock monitor disabled; slow clocks can be used

1 = Slow or stopped clocks cause clock failure reset

**CR1, CR0 — COP Timer Rate Select**

CR [1:0]	Divide $E/2^{15}$ By	XTAL = 4.0 MHz Timeout – 0/+32.8 ms	XTAL = 8.0 MHz Timeout – 0/+16.4 ms	XTAL = 12.0 MHz Timeout – 0/+10.9 ms
0 0	1	32.768 ms	16.384 ms	10.923 ms
0 1	4	131.072 ms	65.536 ms	43.691 ms
1 0	16	524.288 ms	262.140 ms	174.76 ms
1 1	64	2.097 sec	1.049 sec	699.05 ms
	E =	1.0 MHz	2.0 MHz	3.0 MHz

**COPRST — Arm/Reset COP Timer Circuitry**

**\$103A**

	Bit 7	6	5	4	3	2	1	Bit 0
	7	6	5	4	3	2	1	0
RESET:	0	0	0	0	0	0	0	0

Write \$55 to COPRST to arm COP watchdog clearing mechanism.

Write \$AA to COPRST to reset COP watchdog.

**HPRIO** — Highest Priority I-Bit Interrupt and Miscellaneous

**\$103C**

	Bit 7	6	5	4	3	2	1	Bit 0
	RBOOT	SMOD	MDA	IRVNE	PSEL3	PSEL2	PSEL1	PSEL0
RESET:	—	—	—	—	0	1	0	1

RBOOT, SMOD, and MDA reset depends on conditions at reset and can only be written in special modes (SMOD = 1).

RBOOT — Read Bootstrap ROM

- 0 = Boot loader ROM disabled and not in map
- 1 = Boot loader ROM enabled and in map at \$BF40–\$BFFF

SMOD, MDA — Special Mode Select, Mode Select A (Refer to **Operating Modes** .)

IRVNE — Internal Read Visibility/Not E (Refer to **Operating Modes**.)

PSEL3–PSEL0 — Priority Select Bit 3 through Bit 0

Writable only while the I-bit in the CCR is set (interrupts disabled). These bits select one interrupt source to be elevated above all other I-bit related sources.

PSEL [3:0]	Interrupt Source Promoted
0 0 0 0	Timer Overflow
0 0 0 1	Pulse Accumulator Overflow
0 0 1 0	Pulse Accumulator Input Edge
0 0 1 1	SPI Serial Transfer Complete
0 1 0 0	SCI Serial System
0 1 0 1	Reserved (Default to $\overline{IRQ}$ )
0 1 1 0	$\overline{IRQ}$ (External Pin or Parallel I/O)
0 1 1 1	Real-Time Interrupt
1 0 0 0	Timer Input Capture 1
1 0 0 1	Timer Input Capture 2
1 0 1 0	Timer Input Capture 3
1 0 1 1	Timer Output Compare 1
1 1 0 0	Timer Output Compare 2
1 1 0 1	Timer Output Compare 3
1 1 1 0	Timer Output Compare 4
1 1 1 1	Timer Output Compare 5/Input Capture 4

**Electrically Erasable Programmable Read-Only Memory (EEPROM)**

The 512 bytes of EEPROM in the MC68HC11L6 are located at \$B600 through \$B7FF. The EEON bit in CONFIG determines whether or not the EEPROM is in the memory map. When EEON = 1 (erased state), the EEPROM is enabled; when EEON = 0, the EEPROM is disabled and out of the memory map. EEON is reset to the value last programmed into CONFIG.

An on-chip charge pump develops the high voltage required for programming and erasing. When the frequency of the E clock is less than 1 MHz, select an internal clock to drive the EEPROM charge pump by writing one to the CSEL bit in the OPTION register.

Programming and erasing the EEPROM is controlled by the PPROG register and dependent upon the block protect (BPROT) register value.

To erase the EEPROM, ensure that the proper bits of the BPROT register are cleared, then complete the following steps using the PPROG register:

1. Write to PPROG with the ERASE, EELAT, and appropriate BYTE and ROW bits set.
2. Write to the appropriate EEPROM address with any data. Row erase only requires a write to any location in the row. Bulk erase is accomplished by writing to any location in the array.
3. Write to PPROG with ERASE, EELAT, EEPGM, and appropriate BYTE and ROW bits set.
4. Delay for 10 ms or more, as appropriate.
5. Clear the EEPGM bit in PPROG to turn off the high voltage.
6. Clear the PPROG register to reconfigure the EEPROM address and data buses for normal operation.

To program the EEPROM, ensure the proper bits of the BPROT register are cleared, then complete the following steps with the PPROG register:

1. Write to PPROG with the EELAT bit set.
2. Write data to the desired address.
3. Write to PPROG with the EELAT and EEPGM bits set.
4. Delay for 10 ms or more, as appropriate.
5. Clear the EEPGM bit in PPROG to turn off the high voltage.
6. Clear the PPROG register to reconfigure the EEPROM address and data buses for normal operation.

**BPROT — Block Protect**

**\$1035**

	Bit 7	6	5	4	3	2	1	Bit 0
	0	0	0	PTCON	BPRT3	BPRT2	BPRT1	BPRT0
RESET:	0	0	0	1	1	1	1	1

**NOTE**

Block protect register bits can be written to zero (protection disabled) within 64 cycles of a reset in normal modes, or any time in special modes. Block protect register bits can be written to one (protection enabled) at any time.

# Freescale Semiconductor, Inc.

PTCON — Protect for CONFIG

0 = CONFIG register can be programmed or erased normally

1 = CONFIG register can not be programmed or erased

BPRT3–BPRT0 — Block Protect Bits for EEPROM

0 = Protection disabled for associated block

1 = Protection enabled for associated block

Bit Name	Block Protected	Block Size
BPRT0	\$B600–\$B61F	32 Bytes
BPRT1	\$B620–\$B65F	64 Bytes
BPRT2	\$B660–\$B6DF	128 Bytes
BPRT3	\$B6E0–\$B7FF	288 Bytes

**OPTION** — System Configuration Options

**\$1039**

Bit 7	6	5	4	3	2	1	Bit 0
ADPU	CSEL	IRQE*	DLY*	CME	0	CR1*	CR0*

RESET: 0 0 0 1 0 0 0 0

\*Can be written only once in first 64 cycles out of reset in normal modes or at any time in special modes.

ADPU — A/D Power-Up (Refer to **A/D Converter**.)

CSEL — Clock Select

0 = A/D and EEPROM use system E clock

1 = A/D and EEPROM use internal RC clock

IRQE, DLY, CME, CR1, and CR0 — (Refer to **Resets and Interrupts**.)

**PPROG** — EEPROM Programming Control

**\$103B**

Bit 7	6	5	4	3	2	1	Bit 0
ODD	EVEN	0	BYTE	ROW	ERASE	EELAT	EEPGM

RESET: 0 0 0 0 0 0 0 0

ODD — Program Odd Rows in Half of EEPROM (TEST)

EVEN — Program Even Rows in Half of EEPROM (TEST)

BYTE — Byte/Other EEPROM Erase Mode

# Freescale Semiconductor, Inc.

ROW — Row/All EEPROM Erase Mode

BYTE	ROW	Action
0	0	Bulk Erase (All 512 Bytes)
0	1	Row Erase (16 Bytes)
1	0	Byte Erase
1	1	Byte Erase

ERASE — Erase/Normal Control for EEPROM

- 0 = Normal read or program mode
- 1 = Erase mode

EELAT — EEPROM Latch Control

- 0 = EEPROM address and data bus configured for normal reads
- 1 = EEPROM address and data bus configured for programming or erasing

EEPGM — EEPROM Program Command

- 0 = Programming or erase voltage to EEPROM array switched off
- 1 = Programming or erase voltage to EEPROM array switched on

CONFIG — EEPROM, ROM, COP Enables

\$103F

Bit 7	6	5	4	3	2	1	Bit 0
0	0	0	0	NOSEC	NOCOP	ROMON	EEON

RESET: 0 0 0 0 — — — —

NOSEC — EEPROM Security Disable

NOSEC has no meaning unless the security mask option was specified at time of manufacture.

- 0 = Security enabled
- 1 = Security disabled

NOCOP — COP System Disable

- 0 = COP enabled (forces reset on timeout)
- 1 = COP disabled (does not force reset on timeout)

ROMON — ROM Enable

In single chip mode ROMON is forced to one out of reset.

- 0 = 16K ROM removed from the memory map
- 1 = 16K ROM present in the memory map

EEON — EEPROM Enable

- 0 = EEPROM removed from the memory map
- 1 = EEPROM present in the memory map

## Parallel Input/Output

The MC68HC11L6 has up to 46 input/output lines, depending on the operating mode. Port A has three input-only pins, three output-only pins, and two bidirectional I/O pins. Port A shares functions with the timer system.

Port B is an eight-bit output-only port in single chip modes and is the high-order address in expanded modes.

Port C is an eight-bit bidirectional port in single chip modes and the multiplexed address and data bus in expanded modes.

Port D is an six-bit bidirectional port that shares functions with the serial systems.

Port E is an eight-bit input-only port that shares functions with the A/D Converter system.

Port G is an eight-bit bidirectional port in all modes.

## Parallel I/O Handshake

Simple and full handshake input and output functions are available on ports B and C in single-chip modes. The following is a description of the handshake functions.

In simple strobed mode, port B is a strobed output port and port C is a latching input port. The two activities are available simultaneously.

The STRB output is pulsed for two E clock periods each time there is a write to the PORTB register. The INVB bit in the PIOC register controls the polarity of STRB pulses. Port C levels are latched into the alternate port C latch (PORTCL) register on each assertion of the STRA input. STRA edge select, flag and interrupt enable bits are located in the PIOC register. Any or all of the port C lines may still be used as general purpose I/O while in strobed input mode.

Full handshake modes involve port C pins and the STRA and STRB lines. Input and output handshake modes are supported, and output handshake mode has a three-stated variation. STRA is an edge detecting input, and STRB is a handshake output. Control and enable bits are located in the PIOC register.

In full input handshake mode, the MCU uses STRB as a "ready" line to an external system. Port C logic levels are latched into PORTCL when the STRA line is asserted by the external system. The MCU then deasserts STRB. The MCU reasserts STRB after the PORTCL register is read. A mix of latched inputs, static inputs, and static outputs is allowed on port C, differentiated by the data direction bits and use of the PORTC and PORTCL registers.

In full output handshake mode, the MCU writes data to PORTCL, which in turn asserts the STRB output to indicate that data is ready. The external system reads port C and asserts the STRA input to acknowledge that data has been received.

In the three-state variation of output handshake mode, lines intended as three-state handshake outputs are configured as inputs by clearing the corresponding DDRC bits. The MCU writes data to PORTCL and asserts STRB. The external system responds by activating the STRA input, which forces the MCU to drive the data in PORTCL out on all of the port C lines. The mode variation does not allow part of port C to be used for static inputs while other port C pins are being used for handshake outputs. (Refer also to PIOC register description.)

**PORTA — Port A Data**

**\$1000**

	Bit 7	6	5	4	3	2	1	Bit 0
	PA7	PA6	PA5	PA4	PA3	PA2	PA1	PA0
RESET:	HiZ	0	0	0	HiZ	HiZ	HiZ	HiZ
Alt. Pin Func.:	PAI	OC2	OC3	OC4	OC5/IC4	IC1	IC2	IC3
And/or:	OC1	OC1	OC1	OC1	OC1	—	—	—

**PIOC — Parallel I/O Control**

**\$1002**

	Bit 7	6	5	4	3	2	1	Bit 0
	STAF	STAI	CWOM	HNDS	OIN	PLS	EGA	INVB
RESET:	0	0	0	0	0	U	1	1

**STAF — Strobe A Interrupt Status Flag**

Set when selected edge occurs on Strobe A. Cleared by PIOC read with STAF set followed by PORTCL read (simple strobed or full input handshake mode) or PORTCL write (output handshake mode).

**STAI — Strobe A Interrupt Enable Mask**

- 0 = STAF interrupts disabled
- 1 = STAF interrupts enabled

**CWOM — Port C Wire-OR Mode (affects all eight port C pins)**

- 0 = Port C outputs are normal CMOS outputs
- 1 = Port C outputs are open-drain outputs

**HNDS — Handshake Mode**

- 0 = Simple strobe mode
- 1 = Full input or output handshake mode

**OIN — Output or Input Handshake Select**

HNDS must be set to one for this bit to have meaning.

- 0 = Input handshake
- 1 = Output handshake

**PLS — Pulse/Interlocked Handshake Operation**

HNDS must be set to one for this bit to have meaning.

- 0 = Interlocked handshake
- 1 = Pulsed handshake (Strobe B pulses high for two E- clock cycles.)

**EGA — Active Edge for Strobe A**

- 0 = STRA falling edge selected
- 1 = STRA rising edge selected

# Freescale Semiconductor, Inc.

INVB — Invert Strobe B

0 = Active level is logic zero

1 = Active level is logic one

## Parallel I/O Control

	STAF Clearing Sequence	HND S	OIN	PLS	EGA	Port C	Port B
Simple strobed mode	Read PIOC with STAF =1 then read PORTCL	0	X	X		Inputs latched into PORTCL on any active edge on STRA	STRB pulses on writes to port B
Full input handshake	Read PIOC with STAF =1 then read PORTCL	1	0	0 = STRB active level 1 = STRB active pulse		Inputs latched into PORTCL on any active edge on STRA	Normal output port, unaffected in handshake modes
Full output handshake	Read PIOC with STAF =1 then write to PORTCL	1	1	0 = STRB active level 1 = STRB active pulse		Driven as outputs if STRA at active level, follows DDRC if STRA not at active level	Normal output port, unaffected in handshake modes

## PORTC — Port C Data

\$1003

	Bit 7	6	5	4	3	2	1	Bit 0
	PC7	PC6	PC5	PC4	PC3	PC2	PC1	PC0
S. Chip or Boot:	PC7	PC6	PC5	PC4	PC3	PC2	PC1	PC0
RESET:	0	0	0	0	0	0	0	0
Expan. or Test:	A7/D7	A6/D6	A5/D5	A4/D4	A3/D3	A2/D2	A1/D1	A0/D0

### NOTE

In single chip and boot modes, port C pins reset to high impedance inputs (DDRC registers are set to zero). In expanded and special test modes, port C pins become multiplexed address/data bus pins and the port C register address is treated as an external memory location.

**PORTB — Port B Data**

**\$1004**

	Bit 7	6	5	4	3	2	1	Bit 0
	PB7	PB6	PB5	PB4	PB3	PB2	PB1	PB0
S. Chip or Boot:	PB7	PB6	PB5	PB4	PB3	PB2	PB1	PB0
RESET:	0	0	0	0	0	0	0	0
Expn. or Test:	A15	A14	A13	A12	A11	A10	A9	A8

**PORTCL — Port C Latched**

**\$1005**

	Bit 7	6	5	4	3	2	1	Bit 0
	PCL7	PCL6	PCL5	PCL4	PCL3	PCL2	PCL1	PCL0
RESET:	U	U	U	U	U	U	U	U

Writes affect port C pins. PORTCL is used in the handshake clearing mechanism. When an active edge occurs on the STRA pin, port C data is latched into the PORTCL register.

**DDRC — Data Direction for Port C**

**\$1007**

	Bit 7	6	5	4	3	2	1	Bit 0
	DDC7	DDC6	DDC5	DDC4	DDC3	DDC2	DDC1	DDC0
RESET:	0	0	0	0	0	0	0	0

DDC7–DDC0 — Data Direction for Port C

- 0 = Input
- 1 = Output

**PORTD — Port D Data**

**\$1008**

	Bit 7	6	5	4	3	2	1	Bit 0
	0	0	PD5	PD4	PD3	PD2	PD1	PD0
RESET:	0	0	0	0	0	0	0	0
Alt. Pin Func.:	—	—	$\overline{SS}$	SCK	MOSI	MISO	TxD	RxD

**DDRD** — Data Direction for Port D

**\$1009**

	Bit 7	6	5	4	3	2	1	Bit 0
	0	0	DDD5	DDD4	DDD3	DDD2	DDD1	DDD0
RESET:	0	0	0	0	0	0	0	0
Alt. Pin Func.:	—	—	$\overline{SS}$	SCK	MOSI	MISO	TxD	RxD

**DDD5–DDD0** — Data Direction for Port D

When DDRD bit 5 is zero and MSTR = 1 in SPCR, PD5/SS is a general-purpose output, and mode fault logic is disabled.

- 0 = Input
- 1 = Output

**PORTE** — Port E Data

**\$100A**

	Bit 7	6	5	4	3	2	1	Bit 0
	PE7	PE6	PE5	PE4	PE3	PE2	PE1	PE0
RESET:	U	U	U	U	U	U	U	U
Alt. Pin Func.:	AN7	AN6	AN5	AN4	AN3	AN2	AN1	AN0

**PACTL** — Pulse Accumulator Control

**\$1026**

	Bit 7	6	5	4	3	2	1	Bit 0
	DDRA7	PAEN	PAMOD	PEDGE	DDRA3	I4/O5	RTR1	RTR0
RESET:	0	0	0	0	0	0	0	0

**DDRA7** — Data Direction for Port A Bit 7

- 0 = Input
- 1 = Output

**PAEN** — Pulse Accumulator System Enable (Refer to **Pulse Accumulator**.)

**PAMOD** — Pulse Accumulator Mode (Refer to **Pulse Accumulator**.)

**PEDGE** — Pulse Accumulator Edge Control (Refer to **Pulse Accumulator**.)

**DDRA3** — Data Direction for Port A Bit 3

Overridden if an output compare function is configured to control the PA3 pin.

- 0 = Input
- 1 = Output

# Freescale Semiconductor, Inc.

I4/O5 — Input Capture Four/Output Compare 5

0 = OC5 enabled

1 = IC4 enabled

RTR1 and RT0 — Real-Time Interrupt (RTI) Rate (Refer to **Main Timer**.)

---

**PORTG** — Port G Data

**\$1036**

	Bit 7	6	5	4	3	2	1	Bit 0
	PG7	PG6	PG5	PG4	PG3	PG2	PG1	PG0
RESET:	0	0	0	0	0	0	0	0

---

**DDRG** — Data Direction for Port G

**\$1037**

	Bit 7	6	5	4	3	2	1	Bit 0
	DDG7	DDG6	DDG5	DDG4	DDG3	DDG2	DDG1	DDG0
RESET:	0	0	0	0	0	0	0	0

DDG7–DDG0 — Data Direction for Port G

0 = Input

1 = Output

Serial Communications Interface (SCI)

The SCI is a universal asynchronous receiver transmitter (UART) serial communications interface, one of two independent serial I/O subsystems in the MC68HC11L6. It has a standard NRZ format (one start, eight or nine data, and one stop bit) and several of baud rates available. The SCI transmitter and receiver are independent but use the same data format and bit rate.

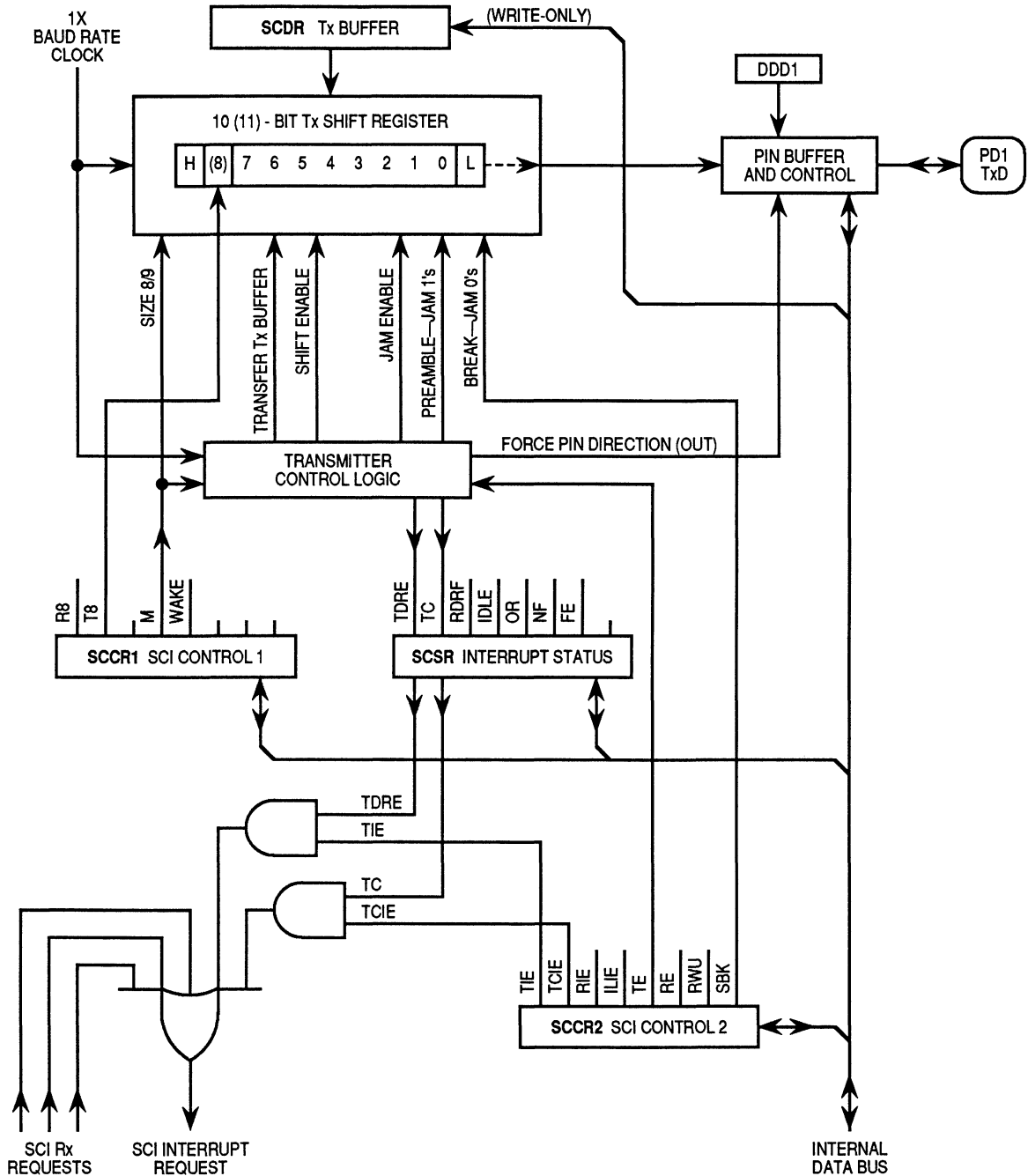

SCI Transmitter Block Diagram

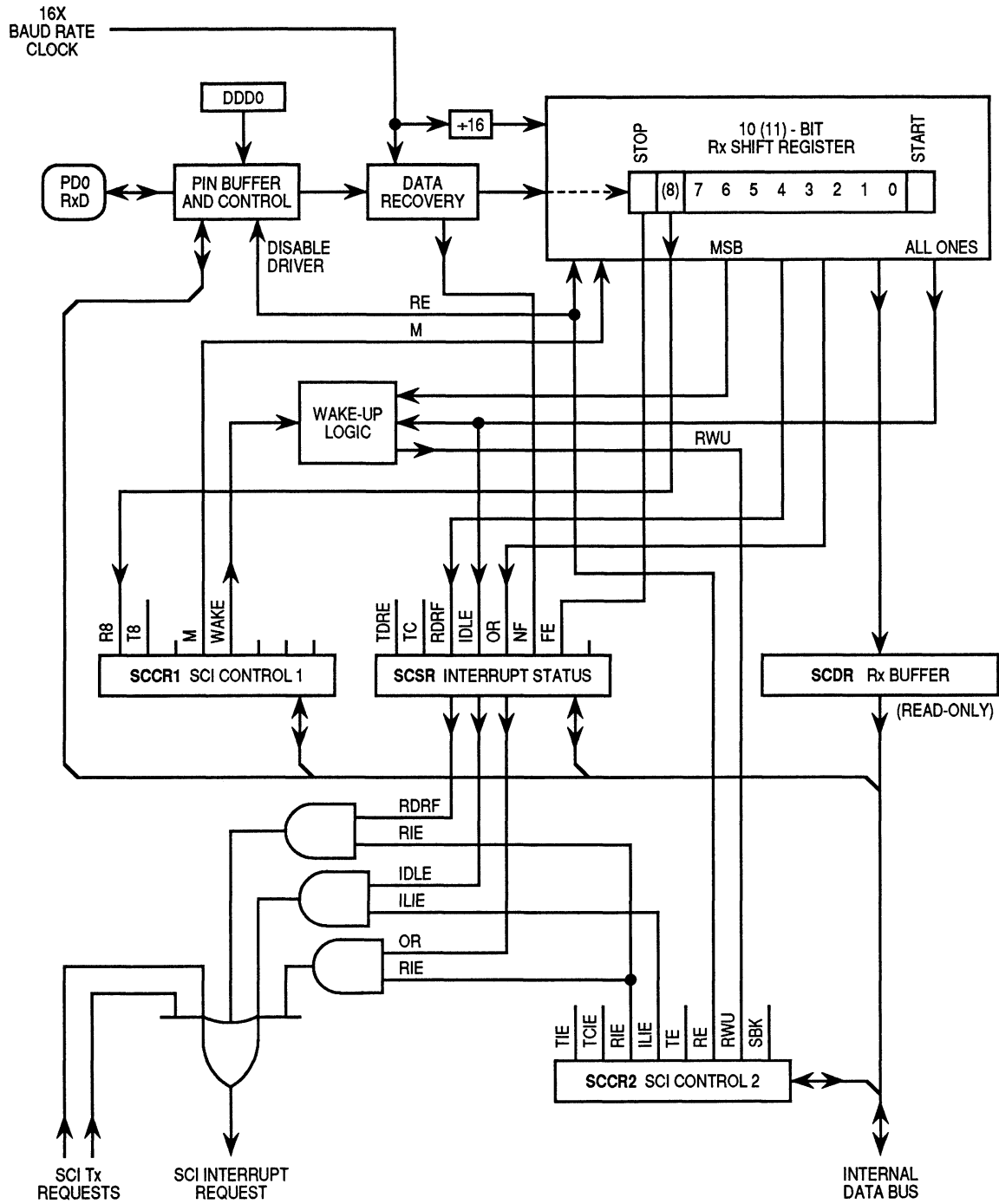

SCI Receiver Block Diagram

## SPCR — Serial Peripheral Control

\$1028

	Bit 7	6	5	4	3	2	1	Bit 0
	SPIE	SPE	DWOM	MSTR	CPOL	CPHA	SPR1	SPR0
RESET:	0	0	0	0	0	1	U	U

DWOM — Port D Wired-OR Mode (affects all six port D pins)

0 = Normal CMOS outputs

1 = Open-drain outputs

Refer to **SPI** section for all other bits.

## BAUD — Baud Rate

\$102B

	Bit 7	6	5	4	3	2	1	Bit 0
	TCLR	0	SCP1	SCP0	RCKB	SCR2	SCR1	SCR0
RESET:	0	0	0	0	0	U	U	U

TCLR — Clear Baud Rate Counters (TEST)

RCKB — SCI Baud Rate Clock Check (TEST)

SCP1, SCP0 — SCI Baud Rate Prescaler Selects

SCP [1:0]		Divide Internal Clock By	Crystal Frequency in MHz			
			4.0 MHz (Baud)	8.0 MHz (Baud)	10.0 MHz (Baud)	12.0 MHz (Baud)
1	0	1	62.50K	125.0K	156.25K	187.5K
0	1	3	20.83K	41.67K	52.08K	62.5K
1	0	4	15.625K	31.25K	38.4K	46.88K
1	1	13	4800	9600	12.02K	14.42K

SCR2, SCR1, and SCR0 — SCI Baud Rate Selects

Selects receiver and transmitter bit rate based on output from baud rate prescaler stage

SCR Bit [2:0]			Divide Prescaler By	Highest Baud Rate (Prescaler Output from Previous Table)		
				4800	9600	38.4K
0	0	0	1	4800	9600	38.4K
0	0	1	2	2400	4800	19.2K
0	1	0	4	1200	2400	9600
0	1	1	8	600	1200	4800
1	0	0	16	300	600	2400
1	0	1	32	150	300	1200
1	1	0	64	—	150	600
1	1	1	128	—	—	300

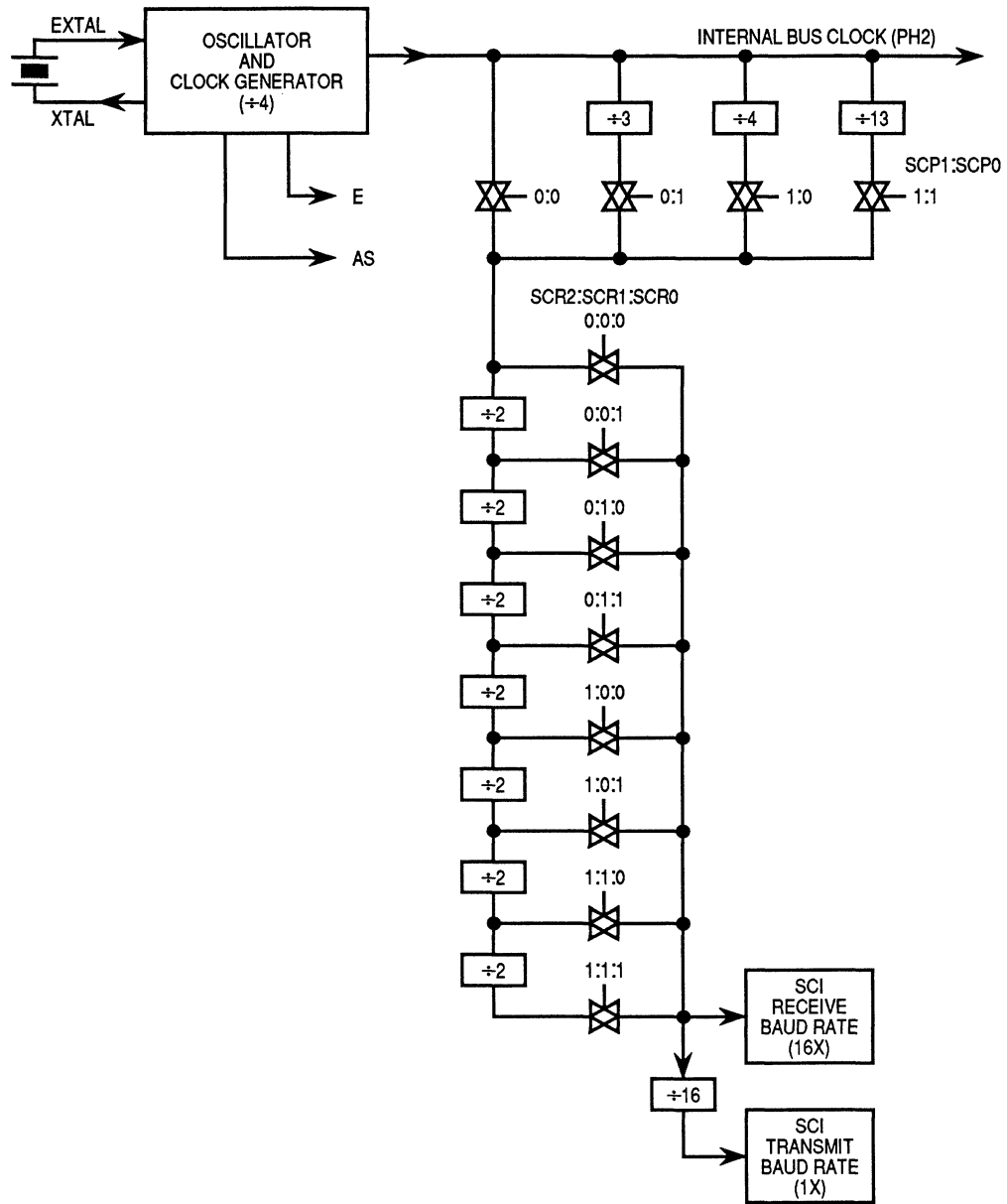

SCI Baud Rate

**SCCR1 — SCI Control 1**

**\$102C**

	Bit 7	6	5	4	3	2	1	Bit 0
	R8	T8	0	M	WAKE	0	0	0
RESET:	U	U	0	0	0	0	0	0

**R8 — Receive Data Bit 8**  
If M bit is set, R8 stores ninth bit in receive data character.

**T8 — Transmit Data bit 8**  
If M bit is set, T8 stores ninth bit in transmit data character.

**M — Mode (Select Character Format)**  
0 = Start, 8 data bits, 1 stop bit  
1 = Start, 9 data bits, 1 stop bit

**WAKE — Wake-Up by Address Mark/Idle**  
0 = Wake up by IDLE line recognition  
1 = Wake up by address mark (most significant data bit set)

**SCCR2 — SCI Control 2**

**\$102D**

	Bit 7	6	5	4	3	2	1	Bit 0
	TIE	TCIE	RIE	ILIE	TE	RE	RWU	SBK
RESET:	0	0	0	0	0	0	0	0

**TIE — Transmit Interrupt Enable**  
0 = TDRE interrupts disabled  
1 = SCI interrupt requested when TDRE status flag is set

**TCIE — Transmit Complete Interrupt Enable**  
0 = TC interrupts disabled  
1 = SCI interrupt requested when TC status flag is set

**RIE — Receiver Interrupt Enable**  
0 = RDRF and OR interrupts disabled  
1 = SCI interrupt requested when RDRF flag or the OR status flag is set

**ILIE — Idle Line Interrupt Enable**  
0 = IDLE interrupts disabled  
1 = SCI interrupt requested when IDLE status flag is set

**TE — Transmitter Enable**  
When TE goes from zero to one, one unit of idle character time (logic one) is queued as a preamble.  
0 = Transmitter disabled  
1 = Transmitter enabled

RE — Receiver Enable  
 0 = Receiver disabled  
 1 = Receiver enabled

RWU — Receiver Wake-Up Control  
 0 = Normal SCI receiver  
 1 = Wake-up enabled and receiver interrupts inhibited

SBK — Send Break  
 0 = Break generator off  
 1 = Break codes generated as long as SBK = 1

**SCSR — SCI Status**

**\$102E**

	Bit 7	6	5	4	3	2	1	Bit 0
	TDRE	TC	RDRF	IDLE	OR	NF	FE	0
RESET:	1	1	0	0	0	0	0	0

TDRE — Transmit Data Register Empty Flag  
 Set if transmit data can be written to SCDR; if TDRE = 0, transmit data register is busy.  
 Cleared by SCSR read with TDRE set, followed by SCDR write.

TC — Transmit Complete Flag  
 Set if transmitter is idle (no data, preamble, or break transmission in progress).  
 Cleared by SCSR read with TC set, followed by SCDR write.

RDRF — Receive Data Register Full Flag  
 Set if a received character is ready to be read from SCDR.  
 Cleared by SCSR read with RDRF set, followed by SCDR read.

IDLE — Idle Line Detected Flag  
 Set if the RxD line is idle. IDLE flag is inhibited when RWU = 1.  
 Cleared by SCSR read with IDLE set, followed by SCDR read.  
 Once cleared, IDLE is not be set again until the RxD line has been active and becomes idle again.

OR — Overrun Error Flag  
 Set if a new character is received before a previously received character is read from SCDR.  
 Cleared by SCSR read with OR set, followed by SCDR read.

NF — Noise Error Flag  
 Set if majority sample logic detects anything other than a unanimous decision.  
 Cleared by SCSR read with NF set, followed by SCDR read.

FE — Framing Error  
 Set if a 0 is detected where a stop bit was expected.  
 Cleared by SCSR read with FE set, followed by SCDR read.

---

SCDR — SCI Data

\$102F

	Bit 7	6	5	4	3	2	1	Bit 0
	R7/T7	R6/T6	R5/T5	R4/T4	R3/T3	R2/T2	R1/T1	R0/T0
RESET:	U	U	U	U	U	U	U	U

Receive and transmit are double buffered. Reads access the receive data buffer, and writes access the transmit data buffer.

---

Freescale Semiconductor, Inc.

**Serial Peripheral Interface (SPI)**

The SPI, an independent serial communications subsystem, allows the MCU to communicate synchronously with peripheral devices and other microprocessors. Data rates can be as high as one-half of the E-clock rate when configured as a master and as fast as the E clock when configured as a slave.

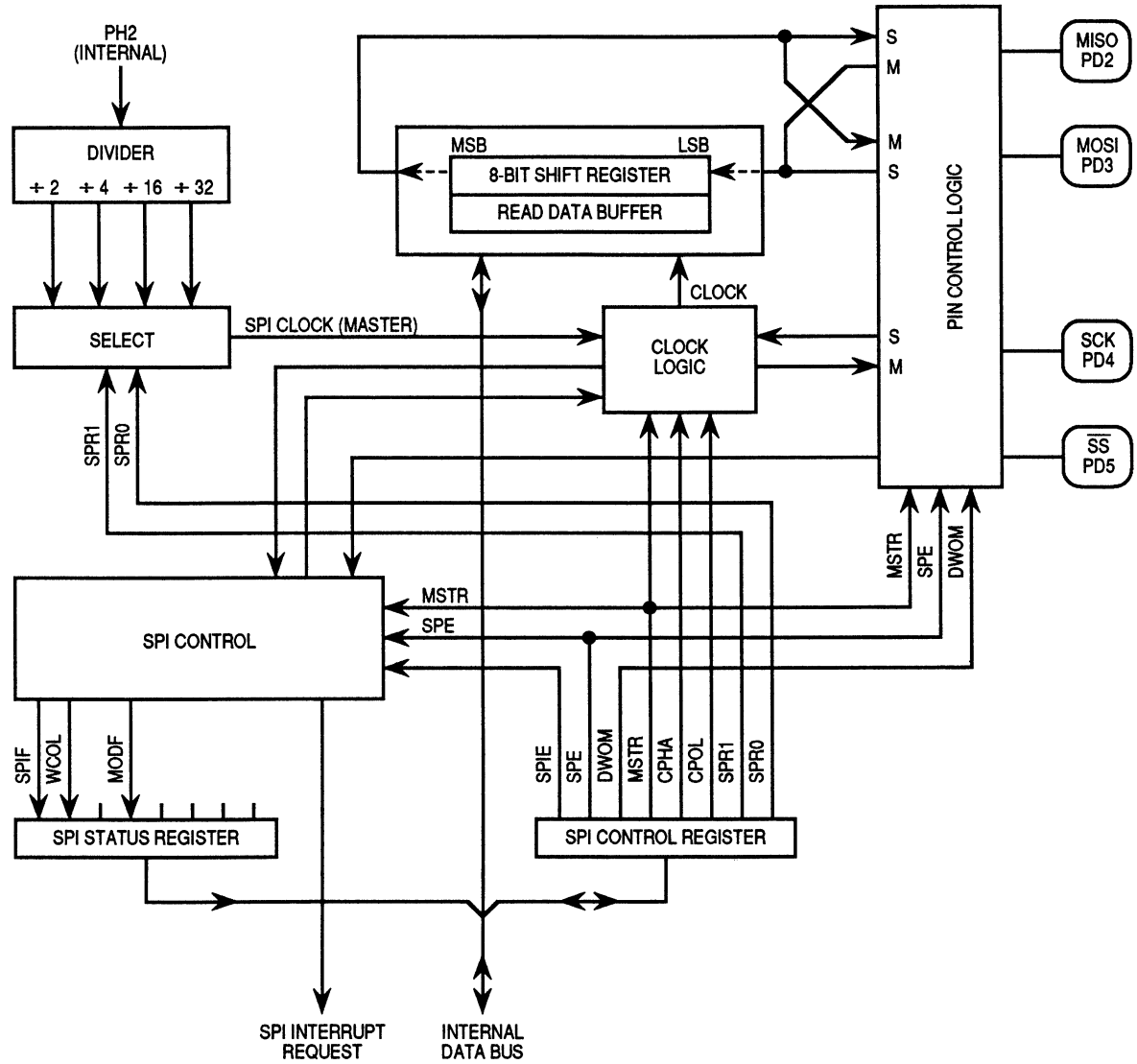

**SPI Block Diagram**

Freescale Semiconductor, Inc.

**DDRD** — Data Direction for Port D

\$1009

	Bit 7	6	5	4	3	2	1	Bit 0
	0	0	DDD5	DDD4	DDD3	DDD2	DDD1	DDD0
RESET:	0	0	0	0	0	0	0	0
Alt. Pin Func.:	—	—	$\overline{SS}$	SCK	MOSI	MISO	TxD	RxD

**DDD5–DDD0** — Data Direction for Port D

When DDRD bit 5 is zero and MSTR = 1 in SPCR, PD5/SS is a general-purpose output and mode fault logic is disabled.

0 = Input

1 = Output

**SPCR** — Serial Peripheral Control

\$1028

	Bit 7	6	5	4	3	2	1	Bit 0
	SPIE	SPE	DWOM	MSTR	CPOL	CPHA	SPR1	SPR0
RESET:	0	0	0	0	0	1	U	U

**SPIE** — Serial Peripheral Interrupt Enable

0 = SPI interrupts disabled

1 = SPI interrupts enabled

**SPE** — Serial Peripheral System Enable

0 = SPI off

1 = SPI on

**DWOM** — Port D Wired-OR Mode

DWOM affects all six port D pins

0 = Normal CMOS outputs

1 = Open-drain outputs

**MSTR** — Master Mode Select

0 = Slave mode

1 = Master mode

**CPOL, CPHA** — Clock Polarity, Clock Phase (Refer to the SPI transfer format.)

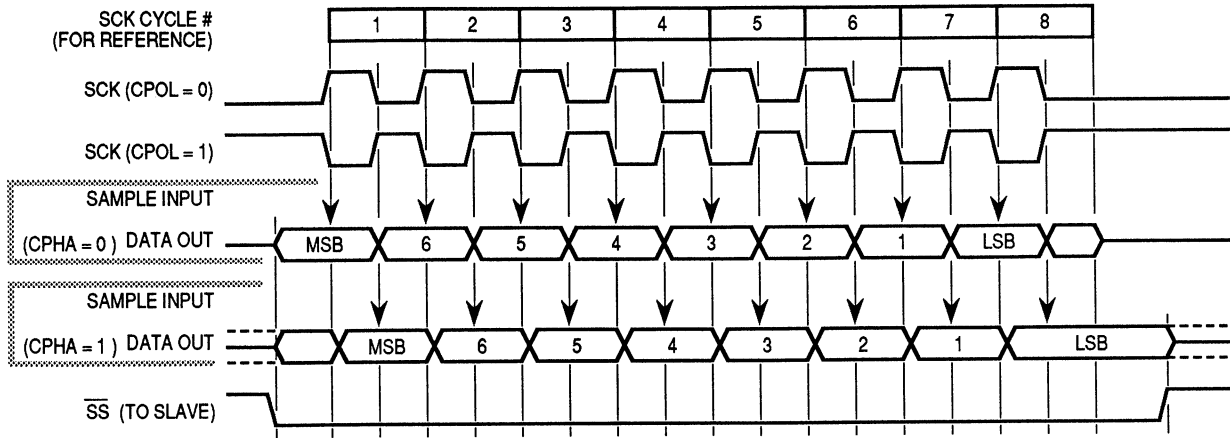

NOTE: This figure shows the LSBF = 0 default case. If LSBF = 1, data is transferred in reverse order (LSB first).

### SPI Transfer Format

SPR1 and SPR0 — SPI Clock Rate Selects

SPR [1:0]		E Clock Divide By	Frequency at E = 2 MHz (Baud)
0	0	2	1.0 MHz
0	1	4	500 kHz
1	0	16	125 kHz
1	1	32	62.5 kHz

SPSR — Serial Peripheral Status

\$1029

Bit 7	6	5	4	3	2	1	Bit 0
SPIF	WCOL	0	MODF	0	0	0	0
RESET:	0	0	0	0	0	0	0

SPIF — SPI Transfer Complete Flag

Set when an SPI transfer is complete.

Cleared by reading SPSR with SPIF set, followed by SPDR access.

WCOL — Write Collision

Set when SPDR is written while transfer is in progress.

Cleared by SPSR with WCOL set, followed by SPDR access.

# Freescale Semiconductor, Inc.

MODF — Mode Fault (A Mode Fault Terminates SPI Operation)

Set when  $\overline{SS}$  is pulled low while MSTR = 1.

Cleared by SPSR read with MODF set, followed by SPCR write.

---

SPDR — SPI Data

\$102A

Bit 7	6	5	4	3	2	1	Bit 0
Bit 7	6	5	4	3	2	1	Bit 0

### NOTE

SPI is double buffered in, single buffered out.

---

## Main Timer

The main timer is based on a free-running 16-bit counter with a four-stage programmable prescaler. A timer overflow function allows software to extend the system's timing capability beyond the counter's 16-bit range.

The timer has three channels of input capture, four channels of output compare, and one channel that can be configured as a fourth input capture or a fifth output compare.

The following table summarizes crystal-related frequencies and periods.

**Timer Summary**

Control Bits	XTAL Frequencies			
	4.0 MHz	8.0 MHz	12.0 MHz	Other Rates
	1.0 MHz	2.0 MHz	3.0 MHz	(E)
	1000 ns	500 ns	333 ns	(1/E)
PR [1:0]	Main Timer Count Rates			
0 0 1 count overflow	1.0 $\mu$ s 65.536 ms	500 ns 32.768 ms	333 ns 21.845 ms	(E/1) (E/2 <sup>16</sup> )
0 1 1 count overflow	4.0 $\mu$ s 262.14 ms	2.0 $\mu$ s 131.07 ms	1.333 $\mu$ s 87.381 ms	(E/4) (E/2 <sup>18</sup> )
1 0 1 count overflow	8.0 $\mu$ s 524.29 ms	4.0 $\mu$ s 262.14 ms	2.667 $\mu$ s 174.76 ms	(E/8) (E/2 <sup>19</sup> )
1 1 1 count overflow	16.0 $\mu$ s 1.049 s	8.0 $\mu$ s 524.29 ms	5.333 $\mu$ s 349.52 ms	(E/16) (E/2 <sup>20</sup> )
RTR [1:0]	Periodic (RTI) Interrupt Rates			
0 0	8.192 ms	4.096 ms	2.731 ms	(E/2 <sup>13</sup> )
0 1	16.384 ms	8.192 ms	5.461 ms	(E/2 <sup>14</sup> )
1 0	32.768 ms	16.384 ms	10.923 ms	(E/2 <sup>15</sup> )
1 1	65.536 ms	32.768 ms	21.845 ms	(E/2 <sup>16</sup> )
CR [1:0]	COP Watchdog Timeout Rates			
0 0	32.768 ms	16.384 ms	10.923 ms	(E/2 <sup>15</sup> )
0 1	131.07 ms	65.536 ms	43.691 ms	(E/2 <sup>17</sup> )
1 0	524.29 ms	262.14 ms	174.76 ms	(E/2 <sup>19</sup> )
1 1	2.097 s	1.049 s	699.05 ms	(E/2 <sup>21</sup> )
Timeout Tolerance (- 0 ms/+...)	32.768 ms	16.4 ms	10.9 ms	(E/2 <sup>15</sup> )



**CFORC — Timer Compare Force**
**\$100B**

	Bit 7	6	5	4	3	2	1	Bit 0
	FOC1	FOC2	FOC3	FOC4	FOC5	0	0	0
RESET:	0	0	0	0	0	0	0	0

**FOC5–FOC1 — Write ones to Force Compare(s)**

0 = Not affected

1 = Output x action occurs

**OC1M — Output Compare 1 Mask**
**\$100C**

	Bit 7	6	5	4	3	2	1	Bit 0
	OC1M7	OC1M6	OC1M5	OC1M4	OC1M3	0	0	0
RESET:	0	0	0	0	0	0	0	0

Set bit(s) to enable OC1 to control corresponding pin(s) of port A

**OC1D — Output Compare 1 Data**
**\$100D**

	Bit 7	6	5	4	3	2	1	Bit 0
	OC1D7	OC1D6	OC1D5	OC1D4	OC1D3	0	0	0
RESET:	0	0	0	0	0	0	0	0

If OC1Mx is set, data in OC1Dx is output to port A bit x on successful OC1 compares

**TCNT — Timer Counter**
**\$100E, \$100F**

\$100E	Bit 15	14	13	12	11	10	9	Bit 8	TCNT (High)
\$100F	Bit 7	6	5	4	3	2	1	Bit 0	TCNT (Low)

TCNT resets to \$0000.

In normal modes, TCNT is read-only.

**TIC1–TIC3 — Timer Input Capture**

**\$1010–\$1015**

\$1010	Bit 15	14	13	12	11	10	9	Bit 8	TIC1 (High)
\$1011	Bit 7	6	5	4	3	2	1	Bit 0	TIC1 (Low)
\$1012	Bit 15	14	13	12	11	10	9	Bit 8	TIC2 (High)
\$1013	Bit 7	6	5	4	3	2	1	Bit 0	TIC2 (Low)
\$1014	Bit 15	14	13	12	11	10	9	Bit 8	TIC3 (High)
\$1015	Bit 7	6	5	4	3	2	1	Bit 0	TIC3 (Low)

TICx is not affected by reset.

**TOC1–TOC4 — Timer Output Compare**

**\$1016–\$101D**

\$1016	Bit 15	14	13	12	11	10	9	Bit 8	TOC1 (High)
\$1017	Bit 7	6	5	4	3	2	1	Bit 0	TOC1 (Low)
\$1018	Bit 15	14	13	12	11	10	9	Bit 8	TOC2 (High)
\$1019	Bit 7	6	5	4	3	2	1	Bit 0	TOC2 (Low)
\$101A	Bit 15	14	13	12	11	10	9	Bit 8	TOC3 (High)
\$101B	Bit 7	6	5	4	3	2	1	Bit 0	TOC3 (Low)
\$101C	Bit 15	14	13	12	11	10	9	Bit 8	TOC4 (High)
\$101D	Bit 7	6	5	4	3	2	1	Bit 0	TOC4 (Low)

All TOCx register pairs reset to ones (\$FFFF).

**TI4O5 — Timer Input Capture 4/Output Compare 5**

**\$101E, \$101F**

\$101E	Bit 15	14	13	12	11	10	9	Bit 8	TI4O5 (High)
\$101F	Bit 7	6	5	4	3	2	1	Bit 0	TI4O5 (Low)

All TI4O5 register pairs reset to ones (\$FFFF).

**TCTL1 — Timer Control 1**

**\$1020**

	Bit 7	6	5	4	3	2	1	Bit 0
	OM2	OL2	OM3	OL3	OM4	OL4	OM5	OL5
RESET:	0	0	0	0	0	0	0	0

OM2–OM5 — Output Mode  
 OL2–OL5 — Output Level

OMx	OLx	Action Taken on Successful Compare
0	0	Timer disconnected from output pin logic.
0	1	Toggle OCx output line.
1	0	Clear OCx output line to 0.
1	1	Set OCx output line to 1.

**TCTL2 — Timer Control 2**

**\$1021**

	Bit 7	6	5	4	3	2	1	Bit 0
	EDG4B	EDG4A	EDG1B	EDG1A	EDG2B	EDG2A	EDG3B	EDG3A
RESET:	0	0	0	0	0	0	0	0

**Timer Control Configuration**

EDGxB	EDGxA	Configuration
0	0	Capture disabled
0	1	Capture on rising edges only
1	0	Capture on falling edges only
1	1	Capture on any edge

**TMSK1 — Timer Interrupt Mask 1**

**\$1022**

	Bit 7	6	5	4	3	2	1	Bit 0
	OC1I	OC2I	OC3I	OC4I	I4O5I	IC1I	IC2I	IC3I
RESET:	0	0	0	0	0	0	0	0

OC1I–OC4I — Output Compare x Interrupt Enable  
 I4O5I — Input Capture 4 or Output Compare 5 Interrupt Enable  
 IC1I–IC3I — Input Capture x Interrupt Enable

**NOTE**

Bits in TMSK1 correspond bit for bit with flag bits in TFLG1. Ones in TMSK1 enable the corresponding interrupt sources.

**TFLG1 — Timer Interrupt Flag 1**

**\$1023**

	Bit 7	6	5	4	3	2	1	Bit 0
	OC1F	OC2F	OC3F	OC4F	I4O5F	IC1F	IC2F	IC3F
RESET:	0	0	0	0	0	0	0	0

Clear flags by writing a one to the corresponding bit position(s).

**OC1F–OC4F — Output Compare x Flag**

Set each time the counter matches output compare x value

**I4O5F — Input Capture 4/Output Compare 5 Flag**

Set by IC4 or OC5, depending on which function was enabled by I4O5-bit in PACTL

**IC1F–IC3F — Input Capture x Flag**

Set each time a selected active edge is detected on the ICx input line

**TMSK2 — Timer Interrupt Mask 2**

**\$1024**

	Bit 7	6	5	4	3	2	1	Bit 0
	TOI	RTII	PAOVI	PAII	0	0	PR1	PR0
RESET:	0	0	0	0	0	0	0	0

TOI — Timer Overflow Interrupt Enable

RTII — Real-time Interrupt Enable

PAOVI — Pulse Accumulator Overflow Interrupt Enable (Refer to **Pulse Accumulator**.)

PAII — Pulse Accumulator Input Edge Interrupt Enable (Refer to **Pulse Accumulator**.)

**NOTE**

Bits in TMSK2 correspond bit for bit with flag bits in TFLG2. Ones in TMSK2 enable the corresponding interrupt sources.

## PR1 and PR0 — Timer Prescaler Select

In normal modes, PR1 and PR0 may only be written once, and the write must be within 64 cycles after reset. (Refer to the timer summary for specific timing values.)

PR [1:0]	Prescaler
0 0	1
0 1	4
1 0	8
1 1	16

## TFLG2 — Timer Interrupt Flag 2

\$1025

	Bit 7	6	5	4	3	2	1	Bit 0
	TOF	RTIF	PAOVF	PAIF	0	0	0	0
RESET:	0	0	0	0	0	0	0	0

Clear flags by writing a one to the corresponding bit position(s).

### TOF — Timer Overflow Flag

Set when TCNT changes from \$FFFF to \$0000.

### RTIF — Real-Time (Periodic) Interrupt Flag

Set periodically (Refer to RTR1:0 bits in PACTL register).

PAOVF — Pulse Accumulator Overflow Flag (Refer to **Pulse Accumulator**.)

PAIF — Pulse Accumulator Input Edge Flag (Refer to **Pulse Accumulator**.)

## PACTL — Pulse Accumulator Control

\$1026

	Bit 7	6	5	4	3	2	1	Bit 0
	DDRA7	PAEN	PAMOD	PEDGE	DDRA3	I4/O5	RTR1	RTR0
RESET:	0	0	0	0	0	0	0	0

DDRA7 — Data Direction for Port A Bit 7 (Refer to **Parallel I/O**.)

PAEN — Pulse Accumulator System Enable (Refer to **Pulse Accumulator**.)

PAMOD — Pulse Accumulator Mode (Refer to **Pulse Accumulator**.)

# Freescale Semiconductor, Inc.

PEDGE — Pulse Accumulator Edge Control (Refer to **Pulse Accumulator**.)

DDRA3 — Data Direction for Port A Bit 3 (Refer to **Parallel I/O**.)

RTR1 and RTR0 — Real-Time Interrupt (RTI) Rate

**Real-Time Interrupt Rates**

RTR [1:0]	Divide E By	XTAL = 4.0 MHz	XTAL = 8.0 MHz	XTAL = 12.0 MHz
0 0	$2^{13}$	8.19 ms	4.096 ms	2.731 ms
0 1	$2^{14}$	16.38 ms	8.192 ms	5.461 ms
1 0	$2^{15}$	32.77 ms	16.384 ms	10.923 ms
1 1	$2^{16}$	65.54 ms	32.768 ms	21.845 ms
	E =	1.0 MHz	2.0 MHz	3.0 MHz

---

**Pulse Accumulator**

The MC68HC11L6 has an 8-bit counter that can be configured to operate as a simple event counter or for gated time accumulation, depending on the PAMOD bit in the PACTL register. The pulse accumulator counter can be read or written at any time.

The port A bit 7 I/O pin can be configured as a clock in event counting mode or as a gate signal to enable a free-running clock (E divided by 64) in gated accumulation mode.

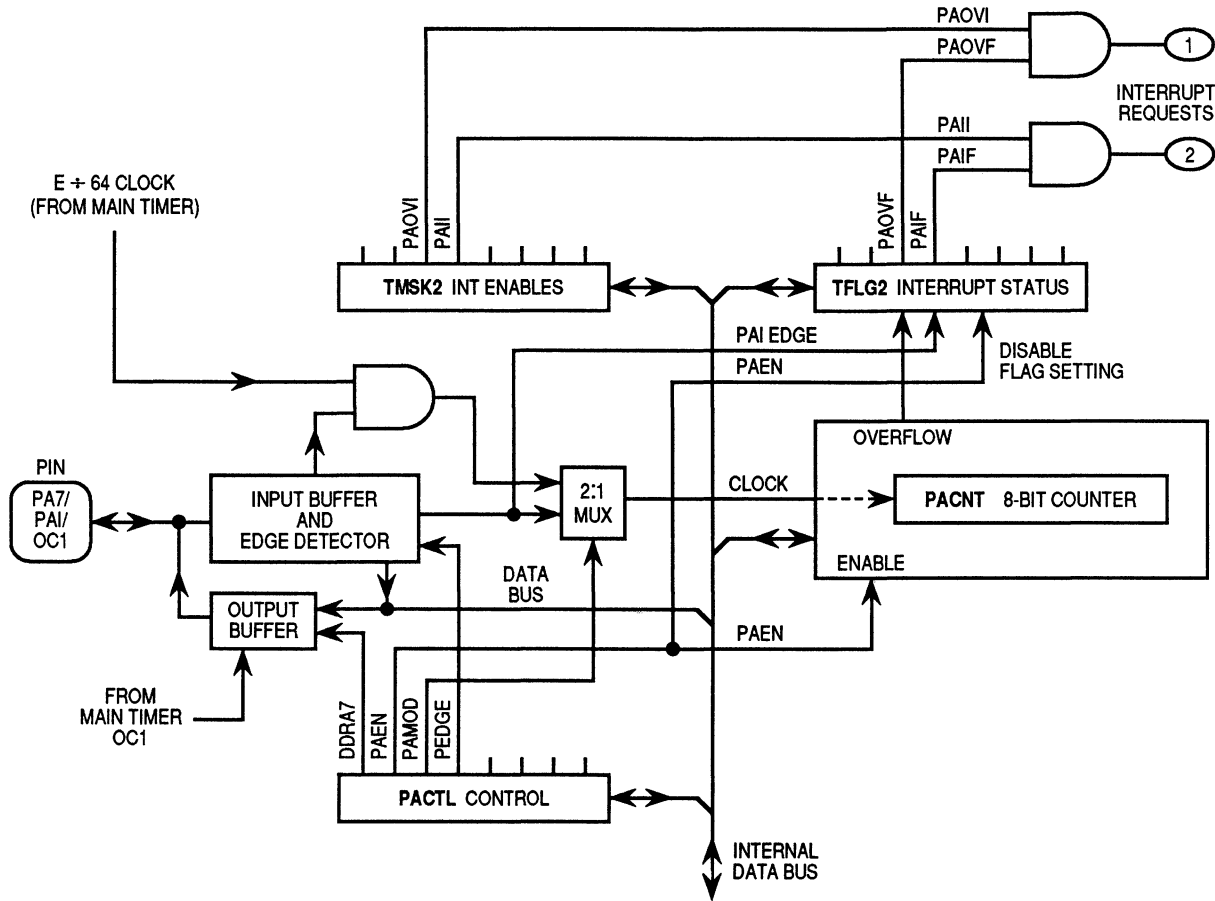

**Pulse Accumulator System Block Diagram**

**Pulse Accumulator Timing**

	Selected Crystal	Common XTAL Frequencies		
		4.0 MHz	8.0 MHz	12.0 MHz
<b>CPU Clock</b>	(E)	1.0 MHz	2.0 MHz	3.0 MHz
<b>Cycle Time</b>	(1/E)	1000 ns	500 ns	333 ns
<b>Pulse Accumulator (in Gated Mode)</b>				
(E/2 <sup>6</sup> ) (E/2 <sup>14</sup> )	1 count overflow	64.0 μs 16.384 ms	32.0 μs 8.192 ms	21.33 μs 5.461 ms

**TMSK2 — Timer Interrupt Mask 2**

**\$1024**

	Bit 7	6	5	4	3	2	1	Bit 0
	TOI	RTII	PAOVI	PAII	0	0	PR1	PR0
RESET:	0	0	0	0	0	0	0	0

TOI — Timer Overflow Interrupt Enable (Refer to **Main Timer**.)

RTII — Real-time Interrupt Enable (Refer to **Main Timer**.)

PAOVI — Pulse Accumulator Overflow Interrupt Enable  
 Set when pulse accumulator count rolls over from \$FF to \$00.  
 Cleared by writing to TFLG2 with a one in bit 4.

PAII — Pulse Accumulator Input Edge Interrupt Enable  
 Set each time a selected edge is detected at PA7/PAI/OC1.  
 Cleared by writing to TFLG2 with a one in bit 5.

**NOTE**

Bits in TMSK2 correspond bit for bit with flag bits in TFLG2. Ones in TMSK2 enable the corresponding interrupt sources.

PR1 and PR0 — Timer Prescaler Select (Refer to **Main Timer**.)

**TFLG2 — Timer Interrupt Flag 2**

**\$1025**

	Bit 7	6	5	4	3	2	1	Bit 0
	TOF	RTIF	PAOVF	PAIF	0	0	0	0
RESET:	0	0	0	0	0	0	0	0

Clear flags by writing a one to the corresponding bit position(s).

TOF — Timer Overflow Flag (Refer to **Main Timer**.)

RTIF — Real-Time (Periodic) Interrupt Flag (Refer to **Main Timer**.)

PAOVF — Pulse Accumulator Overflow Flag  
 Set when PACNT changes from \$FF to \$00.

PAIF — Pulse Accumulator Input Edge Flag  
 Set each time a selected active edge is detected on the PAI input line.

**PACTL — Pulse Accumulator Control**

**\$1026**

	Bit 7	6	5	4	3	2	1	Bit 0
	DDRA7	PAEN	PAMOD	PEDGE	DDRA3	I4/O5	RTR1	RTR0
RESET:	0	0	0	0	0	0	0	0

DDRA7 — Data Direction for Port A Bit 7 (Refer to **Parallel I/O**.)

PAEN — Pulse Accumulator System Enable  
 0 = Pulse Accumulator disabled  
 1 = Pulse Accumulator enabled

PAMOD — Pulse Accumulator Mode  
 0 = Event counter  
 1 = Gated time accumulation

PEDGE — Pulse Accumulator Edge Control

PAMOD	PEDGE	Action on Clock
0	0	PAI Falling Edge Increments the Counter
0	1	PAI Rising Edge Increments the Counter
1	0	A Zero on PAI Inhibits Counting
1	1	A One on PAI Inhibits Counting

DDRA3 — (Refer to **Parallel I/O** )

Input Capture 4/Output Compare 5 — (Refer to **Parallel I/O**.)

RTR1 and RTR0 — (Refer to **Main Timer**.)

**PACNT — Pulse Accumulator Counter**

**\$1027**

	Bit 7	6	5	4	3	2	1	Bit 0
	Bit 7	6	5	4	3	2	1	Bit 0

Readable and writable

**A/D Converter**

The A/D converter system uses an all-capacitive charge-redistribution technique to convert analog signals to digital values. The MC68HC11L6 A/D system, an 8-channel, 8-bit, multiplexed-input, successive-approximation converter, is accurate to  $\pm 1$  least significant bit (LSB). It does not require external sample and hold circuits because of the type of charge-redistribution technique used.

Dedicated lines  $V_{RH}$  and  $V_{RL}$  provide the reference supply voltage inputs.

A multiplexer allows the single A/D converter to select one of 16 analog signals.

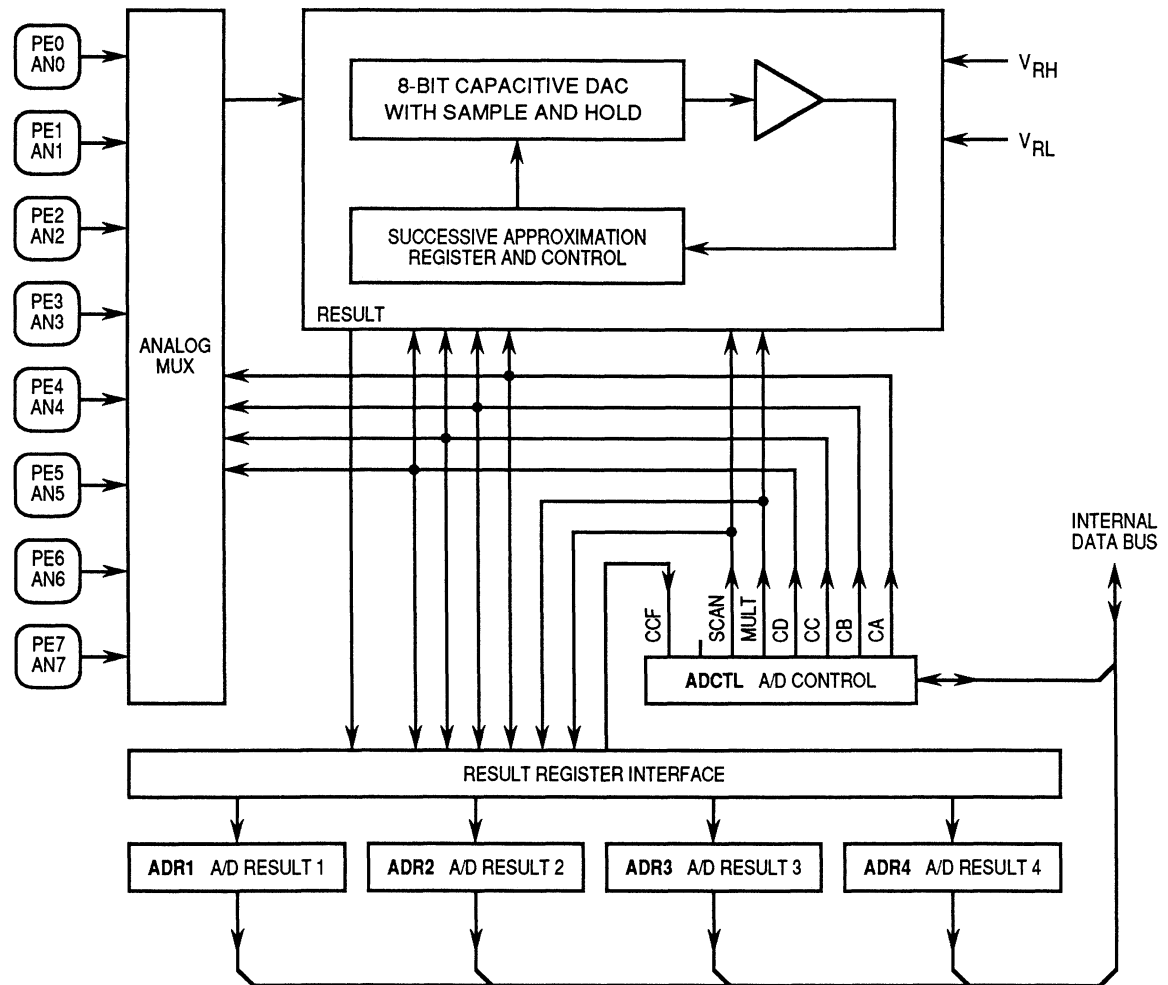

**A/D Converter Block Diagram**

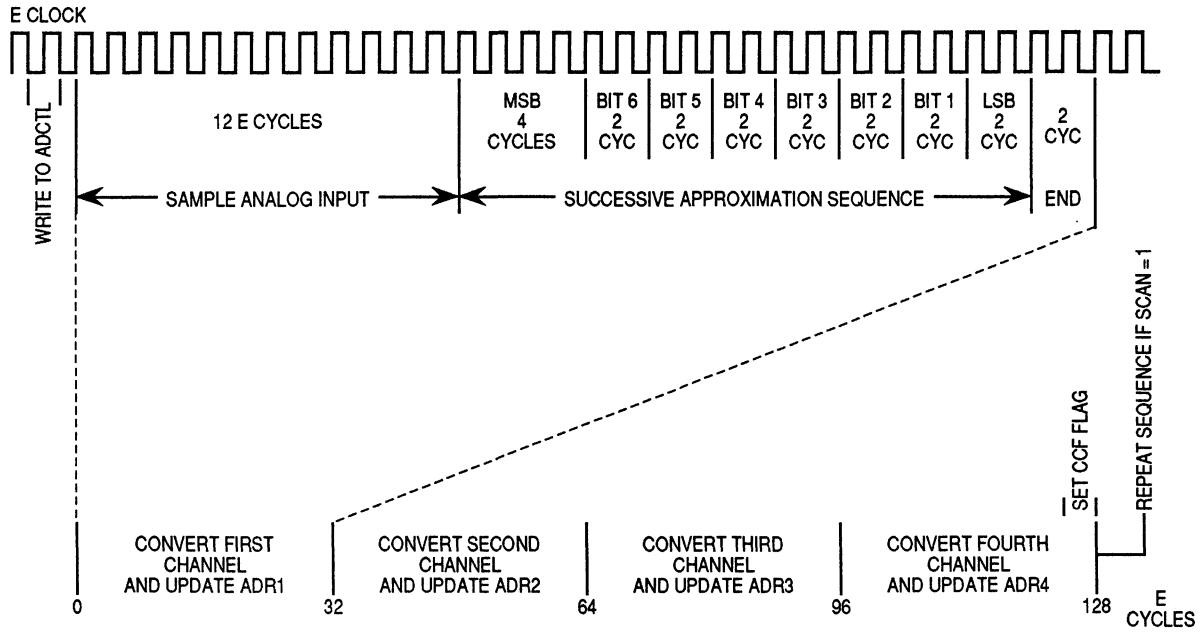

A/D Conversion Sequence

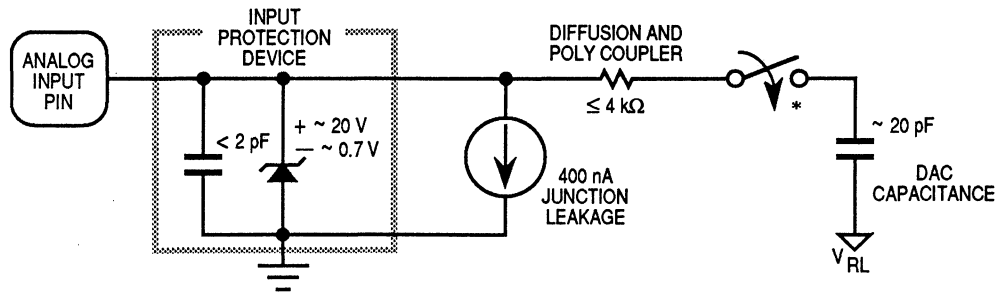

\* This analog switch is closed only during the 12-cycle sample time.

Electrical Model of an Analog Input Pin (Sample Mode)

ADCTL — A/D Control/Status

\$1030

	Bit 7	6	5	4	3	2	1	Bit 0
\$1030	CCF	0	SCAN	MULT	CD	CC	CB	CA
RESET:	0	0	U	U	U	U	U	U

CCF — Conversions Complete Flag

Set after the fourth conversion in an A/D conversion cycle, cleared when ADCTL is written

SCAN — Continuous Scan Control

0 = Do four conversions and stop

1 = Convert four channels in selected group continuously

MULT — Multiple Channel/Single Channel Control

0 = Convert single channel selected

1 = Convert four channels in selected group

CD-CA — Channel Select D through A

A/D Converter Channel Assignments

Channel Select Control Bits				Channel Signal	Result in ADRx if MULT = 1
CD	CC	CB	CA		
0	0	0	0	AN0	ADR1
0	0	0	1	AN1	ADR2
0	0	1	0	AN2	ADR3
0	0	1	1	AN3	ADR4
0	1	0	0	AN4	ADR1
0	1	0	1	AN5	ADR2
0	1	1	0	AN6	ADR3
0	1	1	1	AN7	ADR4
1	0	X	X	Reserved	—
1	1	0	0	VRH*	ADR1
1	1	0	1	VRL*	ADR2
1	1	1	0	(VRH)/2*	ADR3
1	1	1	1	Reserved*	ADR4

\*Used for factory testing

**ADR1–ADR4 — A/D Results**

**\$1031–\$1034**

\$1031	Bit 7	6	5	4	3	2	1	Bit 0	ADR1
\$1032	Bit 7	6	5	4	3	2	1	Bit 0	ADR2
\$1033	Bit 7	6	5	4	3	2	1	Bit 0	ADR3
\$1034	Bit 7	6	5	4	3	2	1	Bit 0	ADR4

**Analog Input to 8-Bit Result Translation Table**

	Bit 7	6	5	4	3	2	1	Bit 0
% (1)	50%	25%	12.5%	6.25%	3.12%	1.56%	0.78%	0.39%
Volts (2)	2.500	1.250	0.625	0.3125	0.1562	0.0781	0.0391	0.0195

(1) % of  $V_{RH}-V_{RL}$       (2) Volts for  $V_{RL} = 0$ ;  $V_{RH} = 5.0$  V

**OPTION — System Configuration Options**

**\$1039**

	Bit 7	6	5	4	3	2	1	Bit 0
	ADPU	CSEL	IRQE*	DLY*	CME	0	CR1*	CR0*
RESET:	0	0	0	1	0	0	0	0

\*Can be written only once in first 64 cycles out of reset in normal modes, or at any time in special modes.

**ADPU — A/D Power Up**  
 0 = A/D Powered down  
 1 = A/D Powered up

**CSEL — Clock Select**  
 0 = A/D and EEPROM use system E clock  
 1 = A/D and EEPROM use internal RC clock

**IRQE —  $\overline{IRQ}$  Select Edge Sensitive Only** (Refer to **Resets and Interrupts.**)

**DLY — Enable Oscillator Start-Up Delay on Exit from STOP** (Refer to **Resets and Interrupts.**)

**CME — Clock Monitor Enable** (Refer to **Resets and Interrupts.**)

**CR1, CR0 — COP Timer Rate Select** (Refer to **Resets and Interrupts.**)

Motorola reserves the right to make changes without further notice to any products herein to improve reliability, function or design. Motorola does not assume any liability arising out of the application or use of any product or circuit described herein; neither does it convey any license under its patent rights nor the rights of others. Motorola products are not designed, intended, or authorized for use as components in systems intended for surgical implant into the body, or other applications intended to support or sustain life, or for any other application in which the failure of the Motorola product could create a situation where personal injury or death may occur. Should Buyer purchase or use Motorola products for any such unintended or unauthorized application, Buyer shall indemnify and hold Motorola and its officers, employees, subsidiaries, affiliates, and distributors harmless against all claims, costs, damages, and expenses, and reasonable attorney fees arising out of, directly or indirectly, any claim of personal injury or death associated with such unintended or unauthorized use, even if such claim alleges that Motorola was negligent regarding the design or manufacture of the part. Motorola and  are registered trademarks of Motorola, Inc. Motorola, Inc. is an Equal Opportunity/Affirmative Action Employer.

#### Literature Distribution Centers:

USA: Motorola Literature Distribution; P.O. Box 20912; Phoenix, Arizona 85036.

EUROPE: Motorola Ltd.; European Literature Center; 88 Tanners Drive, Blakelands, Milton Keynes, MK14 5BP, England.

JAPAN: Nippon Motorola Ltd.; 4-32-1, Nishi-Gotanda, Shinagawa-ku, Tokyo 141 Japan.

ASIA-PACIFIC: Motorola Semiconductors H.K. Ltd.; Silicon Harbour Center, No. 2 Dai King Street, Tai Po Industrial Estate, Tai Po, N.T., Hong Kong.



**MOTOROLA**