

MC68HC705E6 EEPROM COPIER TOOL

User's Guide

Table of contents

1. Introduction	3
2. Check list and requirements	3
3. Installing	3
4. Link to programmer	6
Appendix 1	7
Appendix 2	8
Appendix 3	9

1. Introduction

This manual will guide you through the installation of the MC68HC705E6 EEPROM Copier Tool, referenced hereafter as the E6 Copier. The E6 Copier has been designed for serial EEPROM data access via autonomous control operation such as reading, writing, verifying EEPROM data into/from onboard IIC memory AT24C02.

2. Check list and Requirements

Hardware requirements

Power supply	- A 12-14 volt/300 mA linear power supply source
Tool	- E6 Copier board
Adapters	- four 28 SOIC to 28 DIP programming adapters

Additional tool requirements

IIC Memory EEPROM programmer:

- Any accessible programmer supported AT24C02 memory

Package check list

Contents:

- E6 Copier board
- Three 28 SOIC to 28 DIP programming adapters
- This manual

3. Installing

The E6 Copier is designed to accept MC68HC7(05)E6, MC68HC705P3 8-bit MCU EEPROM data memory. The E6 Copier supported devices:

- MC68HC705E6 (0H51A)
- MC68HC05E6 (0G72G; 0F28B)
- MC68HC705P3 (1F75B)
- MC68HC05P3 (1E25BH) * **Required corresponding programming adapter**

To understand E6 Copier components meaning see Figure 1 and Table1. To install and use the E6 Copier, follow these steps:

- Insert target IC for example, MC68HC705E6 into 28 pins on board socket (see Figure 1) Make sure JP1 mounted, JP2 and JP3 left free
- Note: Solder target IC on corresponding programming adapter (ETL shipped)
- Attach E6 Copier to power supply source (12...14V 200mA linear source)
- Now you should see LED2 "READY" appear to Green color - E6 Copier ready to operate
- Press "RESET" (S1) button and hold button 1...2 seconds to perform any operation

Read (Copy) from Microcontroller EEPROM memory (see Figure 2):

- Press "READ" (S4) button and waiting to complete operation. During "READ" operation 2 - Color LED4 appears to Green color slightly flashing. When operation successfully completed LED2 "READY" will flashing 4 times to confirm finish operation

Errors:

- LED1 appear to Red color continuously in case of unsuccessful operation

Solution:

- Press “RESET” (S1) button again and repeat operation
- Check connection between target IC and E6 Copier programming socket
- Check IRQ level (~ 10V; pin 1) of target IC

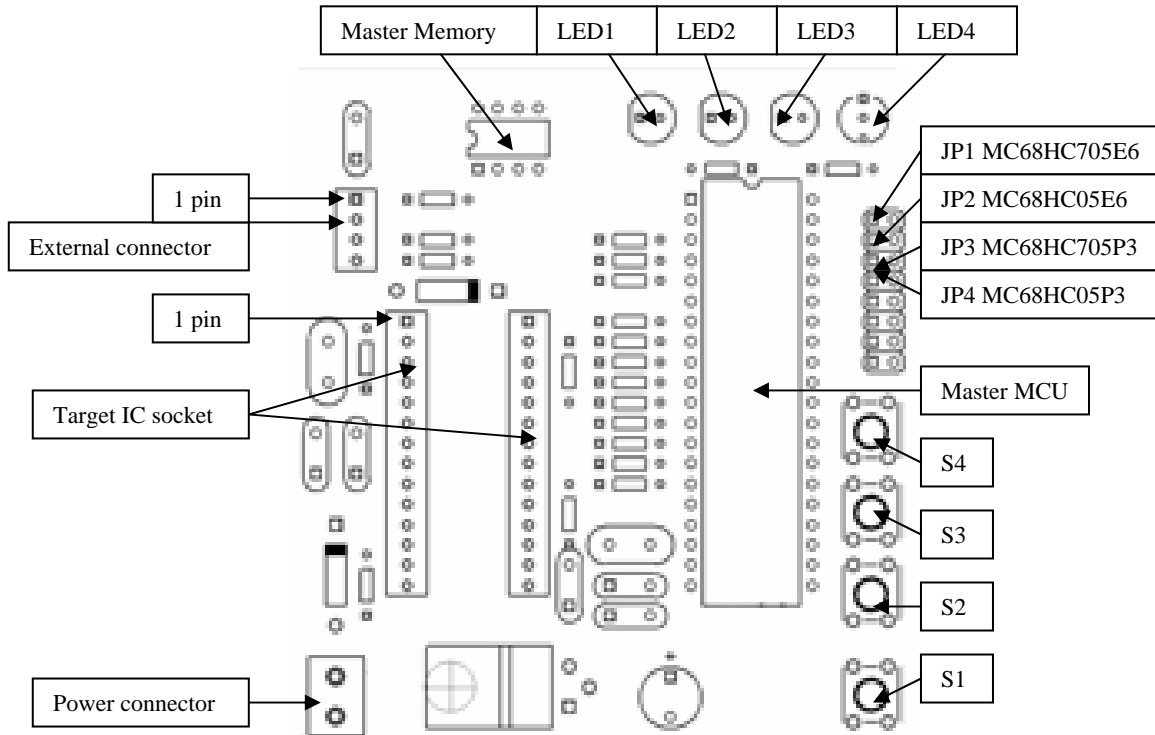

Figure 1.

LED1	“ERROR” LED	Red color
LED2	“READY” LED	Green color
LED3	“VERIFY” LED	Yellow color
LED4	“READ”, “WRITE” LED	Green/Red color; 2-color LED
S1	“RESET”	Reset button
S2	“VERIFY”	Verify button
S3	“WRITE”	Write button
S4	“READ”	Read Button
JP1	MC68HC705E6	Mounted; rest jumpers left free
JP2	MC68HC05E6	Mounted; rest jumpers left free
JP3	MC68HC705P3	Mounted; rest jumpers left free
JP4	MC68HC05P3	Mounted; rest jumpers left free
External connector	4 – pins connector	1-+5V; 2- GND; 3- SCL; 4 –SDA
Master Memory	8 – pins socket	AT24C02 IIC memory
Target IC socket	28 – pins socket	MC68HC7(05)E6/P3 IC socket

Table 1.

Write (Copy) to Microcontroller EEPROM memory (see Figure 2):

- Press “WRITE” (S3) button and waiting to complete operation. During “WRITE” operation 2 - Color LED4 appear to Red color slightly flashing. When operation successfully completed LED2 “READY” will flashing 4 times to confirm finish operation

Errors:

- LED1 appear to Red color continuously in case of unsuccessful operation

Solution:

- Press “RESET” (S1) button again and repeat operation
- Check connection between target IC and E6 Copier programming socket
- Check IRQ level (~ 10V; pin 1) of target IC

Verify EEPROM Microcontroller memory data follow after “WRITE” command:

- Press “VERIFY” (S2) button and waiting to complete operation. During “VERIFY” operation LED3 appear to Yellow color slightly flashing. When operation successfully completed LED2 “READY” will flashing 4 times to confirm complete operation

Errors:

- LED1 will flashing to Red color 8 times in case of unsuccessful finish operation

Solution:

- Press “RESET” (S1) button again and repeat operation
- Press “WRITE” (S3) button again and repeat operation
- Press “VERIFY” (S2) button again and repeat operation
- Check connection between target IC and E6 Copier programming socket
- Check IRQ level (~ 10V; pin 1) of target IC

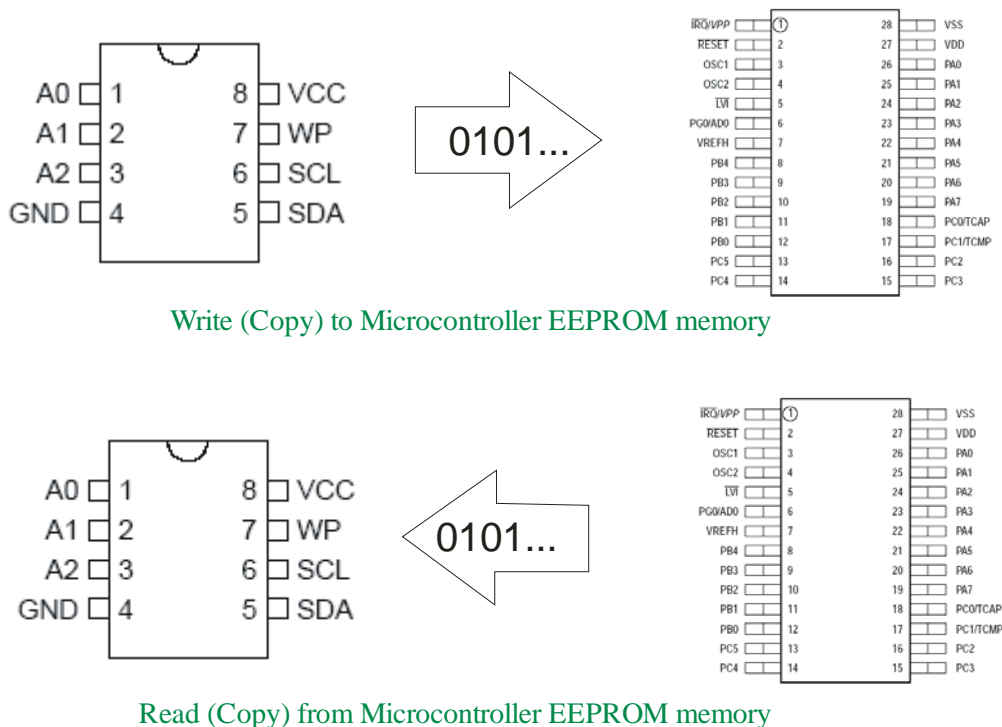

Figure 2.

Any accessible Serial EEPROM programmer supported AT24C02 memory can be use to modification of master memory (AT24C02) data.

4. Link to programmer

In case of necessary users have possibility attach E6 Copier tool direct to Universal Programmer via 4- pins External connector (see Figure 3). E6 Copier tool tested together with Dataman48 or Labtool48, ACE*. Requirements for external programmer: current -50 mA min. single pin driver output

Follow steps:

- Disconnect external power supply source from E6 Copier tool
- Attach flexible wires between 4 - pins External connector of E6 Copier tool and Universal Programmer
- Select AT24C02 device
- Choose corresponding command to access AT24C02 device (Read; Write; Verify)

When operation with AT24C02 device completed do next:

- Disconnect flexible wires between 4 - pins External connector of E6 Copier tool and Universal Programmer
- Connect external power supply source from E6 Copier tool

NOTE* <http://www.dataman.com> ; <http://www.aec.com.tw>;

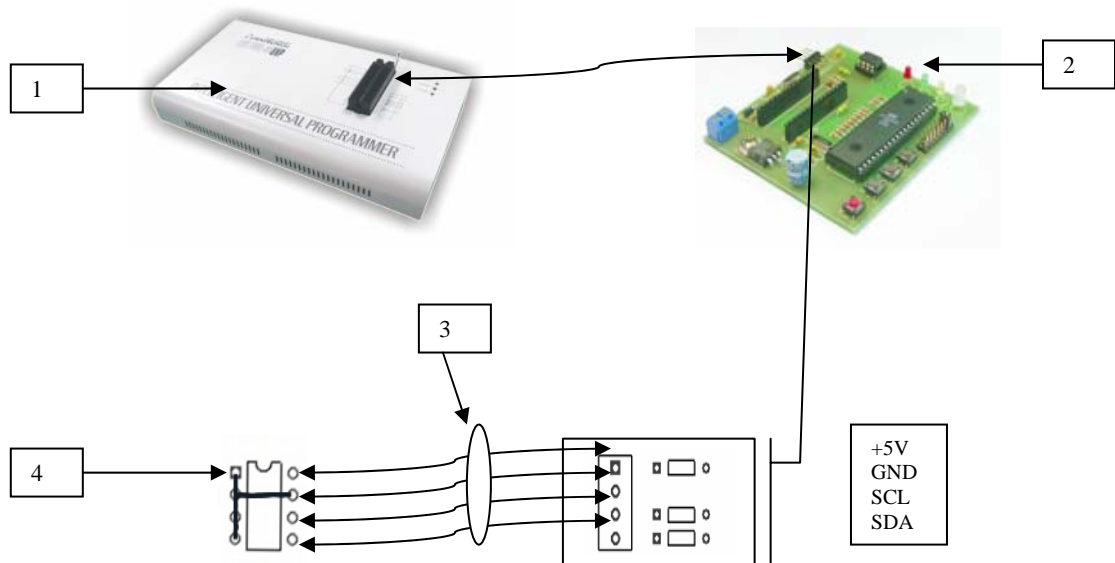

Figure 3.

1. – Universal programmer
2. – E6 Copier tool
3. – Flexible cable between Universal Programmer and E6 Copier tool
4. – Substitute of packaging socket AT24C02

Attention: Improper connection of the E6 Copier tool can damage your target equipment or/and your PC. Inserting or removing substitute of packaging socket AT24C02 while power supply is applied to E6 Copier tool can damage programming equipment.

APPENDIX 1

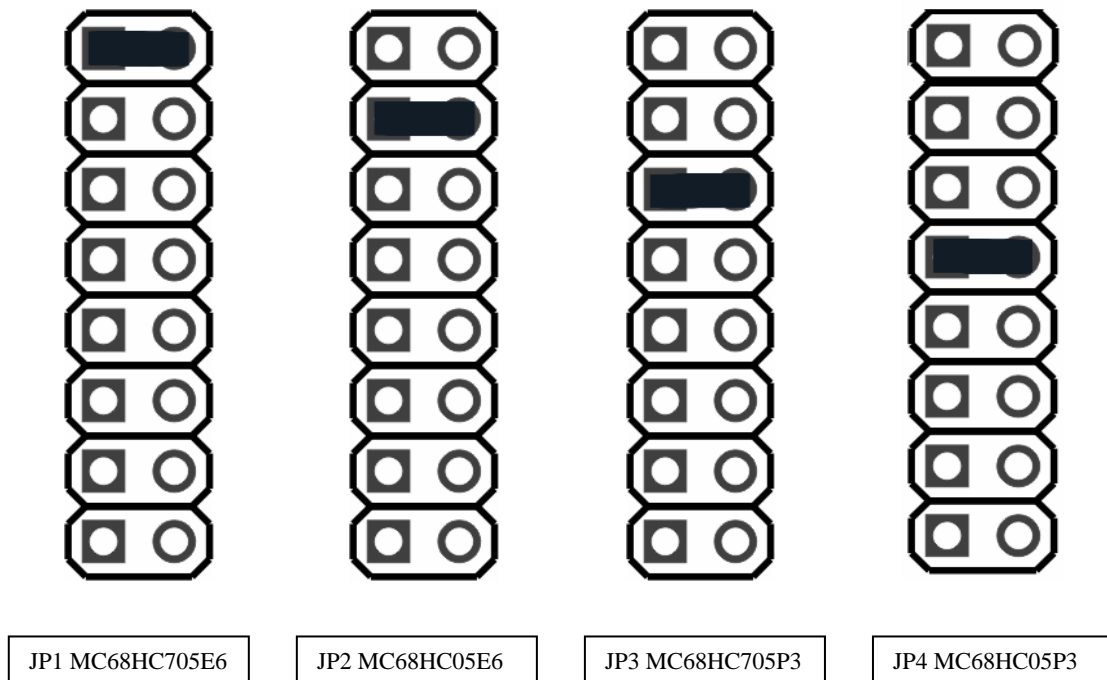

Figure 4.

Jumpers meaning (see Figure 4). One jumper can be mounted at the time only.

EEPROM of microcontrollers in memory map located:

MC68HC705E6:

The 160 byte block of EEPROM is located at address \$0100 to \$019F

MC68HC05E6:

The 160 byte block of EEPROM is located at address \$0100 to \$019F

MC68HC705P3:

The 128 byte block of EEPROM is located at address \$0100 to \$017F

MC68HC05P3:

The 128 byte block of EEPROM is located at address \$0100 to \$017F

Practice test

1. Solder target microcontroller on corresponding programming adapter **
(See Figure 5)
- **Note: MC68HC05P3 (1E25BH) programming adapter not included in set
2. Insert programming adapter into Target IC socket (see Figure 1) according with 1-pin orientation
3. Make sure that JP1, JP2, JP3, JP4 mounted to corresponding position (see Appendix 1)
4. Power ON power supply source (use linear power supply source)
5. Now you should see LED2 appear to Green color, this mean programming tool ready to operate
6. Press (hold button approx.2-3 sec.) S1“RESET” button
7. Press (hold button approx.2-3 sec.) S4 “READ” button and save EEPROM data of target microcontroller into AT24C02
8. Read AT24C02 memory (see Figure 3) by external programmer and save original dump
9. Write AT24C02 memory new data contents or corrected data
10. Press (hold button approx.2-3 sec.) S1“RESET” button
11. Press (hold button approx.2-3 sec.) S3 “WRITE” button and load data from AT24C02 memory into EEPROM of target microcontroller *****Original EEPROM data will lost during WRITE operation and will replace according with AT24C02 memory contents**
12. Press (hold button approx.2-3 sec.) S1“RESET” button
13. Press (hold button approx.2-3 seconds) S2 “VERIFY” button and compare data AT24C02 with data written into EEPROM of target microcontroller

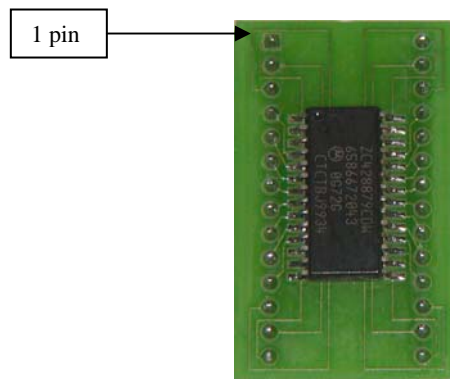

Figure 5.

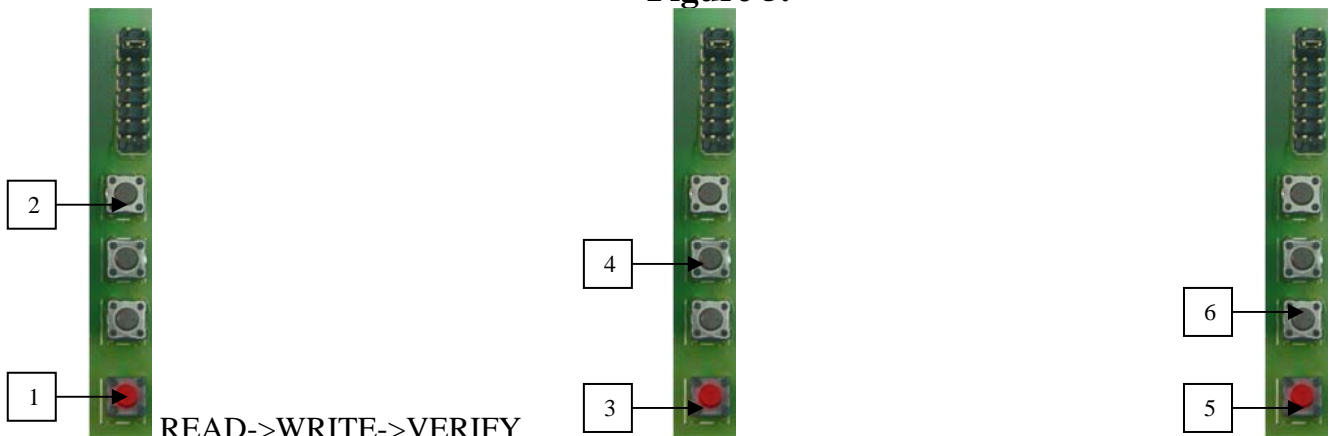

Figure 6.

APPENDIX 3

MC68HC05P3 (1E25H) PROGRAMMING ADAPTER

MC68HC705E6 COPIER TOOL ERRATA

Figure 1 shows the layout of the MC68HC05P3 (1E25BH) programming adapter. All resistors size 1206. As shown in the figure there are special mode to configure MCU according with programming requirements. Make sure before programming device that MC68HC05P3 (1E25BH) place on corresponding programming adapter MC68HC05P3AD.

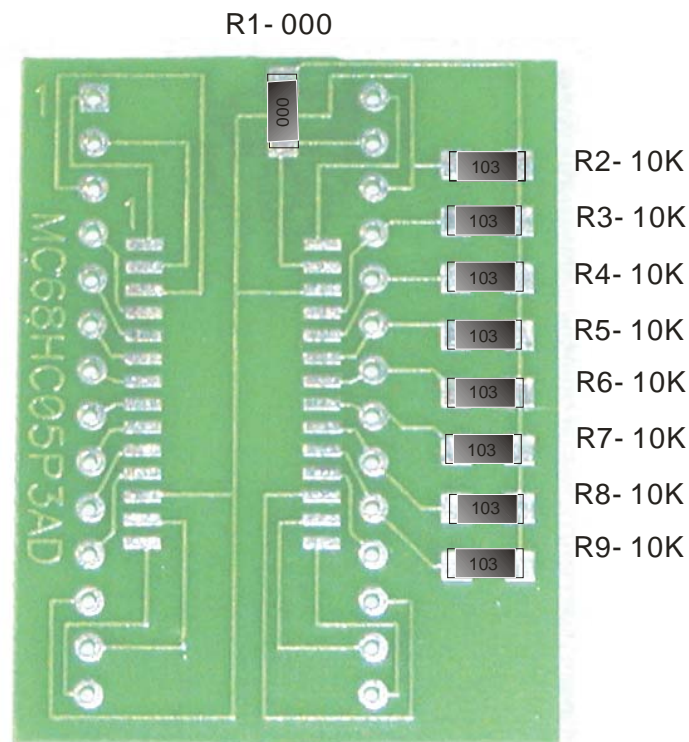

FIGURE 1