

# 68HC(7)05H12

## General Release Specification

### Rev. 1.0

November, 1998

*Motorola reserves the right to make changes without further notice to any products herein to improve reliability, function or design. Motorola does not assume any liability arising out of the application or use of any product or circuit described herein; neither does it convey any license under its patent rights nor the rights of others. Motorola products are not designed, intended, or authorized for use as components in systems intended for surgical implant into the body, or other applications intended to support or sustain life, or for any other application in which the failure of the Motorola product could create a situation where personal injury or death may occur. Should Buyer purchase or use Motorola products for any such unintended or unauthorized application, Buyer shall indemnify and hold Motorola and its officers, employees, subsidiaries, affiliates, and distributors harmless against all claims, costs, damages, and expenses, and reasonable attorney fees arising out of, directly or indirectly, any claim of personal injury or death associated with such unintended or unauthorized use, even if such claim alleges that Motorola was negligent regarding the design or manufacture of the part.*

## List of Sections

List of Sections . . . . .	1
Table of Contents. . . . .	3
List of Figures . . . . .	11
List of Tables . . . . .	15
General Description . . . . .	17
Memory . . . . .	25
CPU and Instruction Set. . . . .	37
Interrupts. . . . .	59
Resets . . . . .	67
Operating Modes . . . . .	75
Input/Output Ports . . . . .	79
Core Timer . . . . .	97
16-Bit Timers . . . . .	103
Serial Peripheral Interface (SPI) . . . . .	115
Serial Communications Interface (SCI). . . . .	125
Analog to Digital Converter . . . . .	143
EEPROM. . . . .	153

## List of Sections

<b>Pulse Width Modulator (PWM)</b> .....	<b>159</b>
<b>EPROM</b> .....	<b>167</b>
<b>Electrical Characteristics</b> .....	<b>173</b>
<b>Mechanical Specifications.</b> .....	<b>183</b>
<b>Index.</b> .....	<b>185</b>

## Table of Contents

### Section 1. General Description

1.1	Contents . . . . .	17
1.2	Introduction . . . . .	17
1.3	Features . . . . .	18
1.4	Mask Options . . . . .	20
1.5	Pin Assignments . . . . .	20
1.6	Functional Pin Description . . . . .	21
1.6.1	VDD and VSS . . . . .	21
1.6.2	AVDD . . . . .	21
1.6.3	OSC1, OSC2 . . . . .	21
1.6.4	RESET . . . . .	21
1.6.5	IRQ/VPP . . . . .	21
1.6.6	PA0–PA7/Keyboard Interrupt . . . . .	22
1.6.7	PB0–PB7/ECLK, MISO, MOSI, SCK . . . . .	22
1.6.8	PC0–PC7/TCAP0–3, TCMP0–1, RDI, TDO . . . . .	22
1.6.9	PD0–PD3/AN0–AN3 . . . . .	23
1.6.10	VREFH . . . . .	23
1.6.11	PE0–PE7 . . . . .	23
1.6.12	PF0–PF3 . . . . .	23
1.6.13	PVDD1, PVSS1, PVDD2, PVSS2 . . . . .	23

### Section 2. Memory

2.1	Contents . . . . .	25
2.2	Introduction . . . . .	25
2.3	Registers . . . . .	26
2.3.1	System Control Register . . . . .	34
2.4	RAM . . . . .	35
2.5	ROM . . . . .	35

2.6	Monitor ROM	35
2.7	User EPROM (for the 705 version only)	35
2.8	EEPROM	35

## Section 3. CPU and Instruction Set

3.1	Contents	37
3.2	Introduction	38
3.3	CPU Registers	38
3.3.1	Accumulator	39
3.3.2	Index Register	39
3.3.3	Stack Pointer	39
3.3.4	Program Counter	40
3.3.5	Condition Code Register	40
3.4	Arithmetic/Logic Unit (ALU)	42
3.5	Instruction Set Overview	42
3.6	Addressing Modes	42
3.6.1	Inherent	43
3.6.2	Immediate	43
3.6.3	Direct	43
3.6.4	Extended	43
3.6.5	Indexed, No Offset	44
3.6.6	Indexed, 8-Bit Offset	44
3.6.7	Indexed, 16-Bit Offset	44
3.6.8	Relative	45
3.7	Instruction Types	45
3.7.1	Register/Memory Instructions	46
3.7.2	Read-Modify-Write Instructions	47
3.7.3	Jump/Branch Instructions	48
3.7.4	Bit Manipulation Instructions	50
3.7.5	Control Instructions	51
3.8	Instruction Set Summary	52

## Section 4. Interrupts

4.1	Contents	59
-----	----------	----

4.2	Introduction . . . . .	60
4.3	CPU Interrupt Processing . . . . .	60
4.4	Reset Interrupt Sequence . . . . .	63
4.5	Software Interrupt (SWI) . . . . .	63
4.6	Hardware Interrupts . . . . .	63
4.7	External Interrupt (IRQ/Keyboard) . . . . .	63
4.8	8-Bit Timer Interrupt . . . . .	64
4.9	16-Bit Timer1 Interrupt . . . . .	64
4.10	16-Bit Timer2 Interrupt . . . . .	64
4.11	SCI Interrupt . . . . .	65
4.12	SPI Interrupt . . . . .	65
4.13	WAIT Mode . . . . .	65

## Section 5. Resets

5.1	Contents . . . . .	67
5.2	Introduction . . . . .	67
5.3	External Reset ( $\overline{\text{RESET}}$ ) . . . . .	67
5.4	Internal Resets . . . . .	68
5.5	Power-On Reset (POR) . . . . .	70
5.6	Computer Operating Properly Reset (COPR) . . . . .	70
5.6.1	Resetting the COP . . . . .	70
5.6.2	COP During WAIT Mode . . . . .	71
5.6.3	COP Watchdog Timer Considerations . . . . .	71
5.6.4	COP Register . . . . .	72
5.7	Illegal Address Reset . . . . .	72
5.8	Low Voltage Reset (LVR) . . . . .	72
5.8.1	LVR Operation in WAIT . . . . .	73
6.1	Contents . . . . .	75

**Section 6. Operating Modes**

6.2	Introduction . . . . .	75
6.3	User Mode . . . . .	75
6.4	Monitor Mode . . . . .	76
6.5	Low Power Modes . . . . .	76
6.5.1	WAIT Mode . . . . .	77
6.5.2	Data Retention Mode . . . . .	78
6.5.3	Slow Mode . . . . .	78

**Section 7. Input/Output Ports**

7.1	Contents . . . . .	79
7.2	Introduction . . . . .	79
7.3	Port A . . . . .	80
7.3.1	Port A Keyboard Interrupt . . . . .	80
7.3.2	Port A Interrupt Edge Register . . . . .	81
7.3.3	Port A Interrupt Control Register . . . . .	81
7.3.4	Port A Interrupt Status Register . . . . .	82
7.4	Port B . . . . .	82
7.5	Port C . . . . .	83
7.6	Port D . . . . .	83
7.7	Port E and Port F (Power Drivers) . . . . .	83
7.7.1	Power Drivers for 360° Air Core Driven Instruments . . . . .	85
7.7.2	H-Bridge Driver . . . . .	86
7.7.3	Power Driver Circuit . . . . .	87
7.7.4	Short Circuit Detection . . . . .	88
7.7.5	Port E and Port F Mismatch Registers . . . . .	89
7.7.6	Driver States . . . . .	90
7.7.7	Port E and Port F Configurations . . . . .	92
7.7.8	H-Bridge Control with the PWM . . . . .	94
7.8	Port E and Port F During WAIT Mode . . . . .	95
7.9	Input/Output Programming . . . . .	95
8.1	Contents . . . . .	97



## Section 8. Core Timer

8.2	Introduction	97
8.3	Registers	99
8.3.1	Core Timer Status and Control Register (CTSCR)	99
8.3.2	Computer Operating Properly (COP) Watchdog Reset	101
8.3.3	Core Timer Counter Register (CTCR)	101
8.4	Core Timer During WAIT	102

## Section 9. 16-Bit Timers

9.1	Contents	103
9.2	Introduction	103
9.3	Registers	105
9.3.1	Counter	105
9.3.2	Output Compare Registers	106
9.3.3	Output Compare Register 1	106
9.3.4	Output Compare Register 2	107
9.3.5	Input Capture Registers	108
9.3.6	Input Capture Register 1	108
9.3.7	Input Capture Register 2	109
9.3.8	Timer Control Register 1	110
9.3.9	Timer Control Register 2	112
9.3.10	Timer Status Register	113
9.4	Timer During WAIT Mode	114

## Section 10. Serial Peripheral Interface (SPI)

10.1	Contents	115
10.2	Introduction	115
10.3	SPI Signal Description	116
10.3.1	Master In Slave Out (MISO)	116
10.3.2	Master Out Slave In (MOSI)	117
10.3.3	Serial Clock (SCK)	117
10.4	SPI Functional Description	119
10.5	Registers	121
10.5.1	SPI Control Register (SPCR)	121

10.5.2	SPI Status Register (SPSR) .....	123
10.5.3	SPI Data I/O Register (SPDAT) .....	124
10.6	SPI During WAIT Mode .....	124

### Section 11. Serial Communications Interface (SCI)

11.1	Contents .....	125
11.2	Introduction .....	125
11.3	Data Format .....	130
11.4	Receiver Wake-up Operation .....	130
11.4.1	Idle Line Wake-up .....	131
11.4.2	Address Mark Wake-up .....	131
11.5	Receive Data (RDI) .....	132
11.6	Start Bit Detection .....	132
11.7	Transmit Data (TDO) .....	135
11.8	Registers .....	135
11.8.1	Serial Communications Data Register (SCDAT) .....	135
11.8.2	Serial Communications Control Register 1 (SCCR1) .....	136
11.8.3	Serial Communications Control Register 2 (SCCR2) .....	137
11.8.4	Serial Communications Status Register (SCSR) .....	138
11.8.5	Baud Rate Register (BAUD) .....	140
11.9	SCI During WAIT Mode .....	142

### Section 12. Analog to Digital Converter

12.1	Contents .....	143
12.2	Introduction .....	144
12.3	A/D Principle .....	144
12.4	A/D Operation .....	145
12.5	Internal and Master Oscillator .....	145
12.6	A/D Registers .....	146
12.6.1	A/D Status and Control Register (ADSCR) .....	146
12.6.2	A/D Data Register .....	148
12.7	A/D During WAIT Mode .....	148
12.8	Analog Input .....	148

12.9	Conversion Accuracy Definitions . . . . .	150
12.9.1	Transfer Curve . . . . .	150
12.9.2	Monotonicity . . . . .	150
12.9.3	Quantization Error . . . . .	151
12.9.4	Offset Error . . . . .	151
12.9.5	Gain Scale Error . . . . .	151
12.9.6	Differential Linearity Error . . . . .	151
12.9.7	Integral Linearity Error . . . . .	151
12.9.8	Total Unadjusted Error . . . . .	151

### **Section 13. EEPROM**

13.1	Contents . . . . .	153
13.2	Introduction . . . . .	153
13.3	EEPROM Control Register (EEPCR) . . . . .	154
13.4	EEPROM Options Register (EEOPR) . . . . .	155
13.5	EEPROM Read, Erase and Programming Procedures . . . . .	156
13.5.1	Read Procedure . . . . .	156
13.5.2	Erase Procedure . . . . .	156
13.5.3	Programming Procedure . . . . .	157
13.6	Operation in WAIT . . . . .	157

### **Section 14. Pulse Width Modulator (PWM)**

14.1	Contents . . . . .	159
14.2	Introduction . . . . .	159
14.3	Functional Description . . . . .	160
14.3.1	PWM Channel Microshifting . . . . .	161
14.4	Registers . . . . .	162
14.4.1	PWM Data Registers . . . . .	163
14.4.2	PWM Control Register . . . . .	164
14.4.3	PWM Channel Enable Register . . . . .	165
14.4.4	PWM Channel Polarity Register . . . . .	165
14.5	PWM During WAIT Mode . . . . .	166

## Section 15. EPROM

15.1	Contents	167
15.2	Introduction	167
15.3	EPROM Bootloader	167
15.3.1	Bootloader Functions	168
15.4	EPROM Programming	170
15.4.1	EPROM Programming Register (EPROG)	170
15.5	Mask Option Register (MOR)	171

## Section 16. Electrical Characteristics

16.1	Contents	173
16.2	Maximum Ratings	174
16.3	Thermal Characteristics	175
16.4	Power Considerations	175
16.5	DC Electrical Characteristics	176
16.6	Control Timing	178
16.7	A/D Converter Characteristics	178
16.8	EEPROM Characteristics	179
16.9	EPROM Characteristics	180
16.10	Power Driver Characteristics	180
16.11	Power-on Reset/Low Voltage Reset Characteristics	181

## Section 17. Mechanical Specifications

17.1	Contents	183
17.2	Pin Assignments	183
17.3	Package Dimensions	184

## Index

## List of Figures

Figure	Title	Page
1-1	MC68HC(7)05H12 Block Diagram . . . . .	19
1-2	MC68HC(7)05H12 Pin Assignments (52-pin PLCC package) . . . . .	20
2-1	MC68HC(7)05H12 Memory Map . . . . .	26
2-2	I/O Register Summary . . . . .	27
2-3	I/O Registers \$0000–\$000F . . . . .	29
2-4	I/O Registers \$0010–\$001F . . . . .	30
2-5	I/O Registers \$0020–\$002F . . . . .	31
2-6	I/O Registers \$0030–\$003F . . . . .	32
2-7	I/O Registers \$0040–\$004F . . . . .	33
2-8	System Control Register (SYSCR). . . . .	34
3-1	Programming Model . . . . .	38
3-2	Accumulator . . . . .	39
3-3	Index Register . . . . .	39
3-4	Stack Pointer . . . . .	39
3-5	Program Counter . . . . .	40
3-6	Condition Code Register . . . . .	40
4-1	Interrupt Processing Flowchart. . . . .	62
5-1	Internal Resets . . . . .	68
5-2	$\overline{\text{RESET}}$ and POR Timing Diagram . . . . .	69
5-3	COP Watchdog Timer Location Register (COPR) . . . . .	72
5-4	Low Voltage Reset . . . . .	73
6-1	WAIT Flowchart . . . . .	77
7-1	Port A Interrupt Edge Register (PAIED). . . . .	81
7-2	Port A Interrupt Control Register (PAICR) . . . . .	81
7-3	Port A Interrupt Status Register (PAISR) . . . . .	82
7-4	Port E and Port F (Power Drivers) . . . . .	84
7-5	Driving Cross Coupled Coils . . . . .	85

7-6	H-Bridge Driver Circuit . . . . .	86
7-7	Power Driver Circuit . . . . .	87
7-8	Short Circuit Detection Circuitry . . . . .	88
7-9	Port E Mismatch Register (PEMISM) . . . . .	89
7-10	Port F Mismatch Register (PFMISM) . . . . .	90
7-11	H-Bridge States . . . . .	91
7-12	Port E Configuration for two 360° instruments . . . . .	92
7-13	Port F Configuration for four 90° instruments (version 1) . . . . .	93
7-14	Port F Configuration for four 90° instruments (version 2) . . . . .	93
7-15	H-Bridge Control with PWM . . . . .	94
7-16	Correspondence between Data and PWM Values . . . . .	95
7-17	Port I/O Circuitry . . . . .	96
8-1	Core Timer Block Diagram . . . . .	98
8-2	Core Timer Status and Control Register (CTSCR) . . . . .	99
8-3	Core Timer Counter Register (CTCR) . . . . .	102
9-1	Timer Block Diagram (Timer1) . . . . .	104
9-2	16-Bit Timer Register Addresses (Timer1) . . . . .	105
9-3	Timer Control Register 1 (TCR1) . . . . .	110
9-4	Timer Control Register 2 (TCR2) . . . . .	112
9-5	Timer Status Register (TSR) . . . . .	113
10-1	Data Clock Timing Diagram . . . . .	118
10-2	Serial Peripheral Block Diagram . . . . .	119
10-3	Serial Peripheral Interface Master-Slave Interconnection . . . . .	120
10-4	SPI Control Register (SPCR) . . . . .	121
10-5	SPI Status Register (SPSR) . . . . .	123
10-6	SPI Data I/O Register (SPDAT) . . . . .	124
11-1	Serial Communications Interface Block Diagram . . . . .	128
11-2	Data Format . . . . .	130
11-3	Sampling Technique Used On All Bits . . . . .	132
11-4	Examples of Start Bit Sampling Techniques . . . . .	133
11-5	SCI Artificial Start Following a Framing Error . . . . .	134
11-6	SCI Start Bit Following a Break . . . . .	134
11-7	SCI Data Register (SCDAT) . . . . .	135
11-8	SCI Control Register 1 (SCCR1) . . . . .	136
11-9	SCI Control Register 2 (SCCR2) . . . . .	137

11-10	SCI Status Register (SCSR) . . . . .	138
11-11	SCI Baud Rate Register (BAUD) . . . . .	140
12-1	A/D Status and Control Register (ADSCR) . . . . .	146
12-2	A/D Data Register (ADDR) . . . . .	148
12-3	Electrical Model of an A/D Input Pin. . . . .	149
12-4	Transfer Curve of an Ideal 8-Bit A/D Converter . . . . .	150
13-1	EEPROM Control Register (EEPCR) . . . . .	154
13-2	EEPROM Options Register (EEOPR) . . . . .	155
14-1	PWM Block Diagram (one channel) . . . . .	160
14-2	PWM Microshifts . . . . .	161
14-3	PWM Data Registers (PWM0–7) . . . . .	163
14-4	PWM Control Register (PWMCTL) . . . . .	164
14-5	PWM Channel Enable Register (PWMEN) . . . . .	165
14-6	PWM Channel Polarity Register (PWMPOL) . . . . .	165
15-1	MC68HC705H12 Programming Circuit . . . . .	169
15-2	EPROM Programming Register (EPROG) . . . . .	170
15-3	Mask Options Registers (MOR1 and MOR2) . . . . .	171
17-1	52-Pin PLCC Pin Assignments . . . . .	183
17-2	52-Pin PLCC Package Dimensions . . . . .	184





## List of Tables

Table	Title	Page
3-1	Register/Memory Instructions . . . . .	46
3-2	Read-Modify-Write Instructions . . . . .	47
3-3	Jump and Branch Instructions . . . . .	49
3-4	Bit Manipulation Instructions . . . . .	50
3-5	Control Instructions . . . . .	51
3-6	Instruction Set Summary . . . . .	52
3-7	Opcode Map . . . . .	58
4-1	Reset/Interrupt Vector Addresses . . . . .	61
6-1	Operating Mode Entry Conditions . . . . .	75
7-1	I/O Pin Functions . . . . .	96
8-1	RTI Rates . . . . .	100
8-2	Minimum COP Reset Times . . . . .	101
10-1	SPI Clock Rate Selection . . . . .	122
11-1	First Prescaler Stage . . . . .	141
11-2	Second Prescaler Stage . . . . .	141
12-1	A/D Clock Selection . . . . .	147
12-2	A/D Channel Assignments . . . . .	147
13-1	Erase Mode Select . . . . .	154
14-1	PWM Clock Rate . . . . .	164
15-1	Bootloader Functions . . . . .	168



## Section 1. General Description

### 1.1 Contents

1.2	Introduction	17
1.3	Features	18
1.4	Mask Options	20
1.5	Pin Assignments	20
1.6	Functional Pin Description	21
1.6.1	VDD and VSS	21
1.6.2	AVDD	21
1.6.3	OSC1, OSC2	21
1.6.4	RESET	21
1.6.5	IRQ/VPP	21
1.6.6	PA0–PA7/Keyboard Interrupt	22
1.6.7	PB0–PB7/ECLK, MISO, MOSI, SCK	22
1.6.8	PC0–PC7/TCAP0–3, TCMP0–1, RDI, TDO	22
1.6.9	PD0–PD3/AN0–AN3	23
1.6.10	VREFH	23
1.6.11	PE0–PE7	23
1.6.12	PF0–PF3	23
1.6.13	PVDD1, PVSS1, PVDD2, PVSS2	23

### 1.2 Introduction

The MC68HC(7)05H12 HCMOS microcomputer is a member of the M68HC05 family. This 8 bit microcomputer unit (MCU) contains on-chip oscillator, CPU, RAM, (EP)ROM, monitor ROM, EEPROM, parallel I/O, one core timer, COP watchdog system, two 16-bit programmable timers, synchronous and asynchronous serial interface, a 4 channel A/D converter, and an 8 channel 8-bit PWM with on-chip power driver circuitry.

### 1.3 Features

- HC05 core
- 52 PLCC package
- 12032 bytes of user (EP)ROM + 240 bytes of monitor ROM + 16 bytes user vectors
- 256 bytes of RAM
- 256 bytes of EEPROM
- Multipurpose core timer, real time interrupt (RTI), COP watchdog timer
- Two 16-bit timers with two input captures and two output compares each
- Serial peripheral interface (SPI)
- Serial communications interface (SCI)
- 4 channel A/D converter (8-bit resolution)
- Keyboard interrupt for 8 I/O lines
- 8 channel 8-bit PWM system for control of H-bridge drivers
- 12 special power drivers to drive two major gauges and four minor gauges, with short circuit detection and slew rate limitation for reduced RFI (EMC)
- Power saving WAIT mode
- 2 selectable bus frequencies (slow mode)
- Low voltage reset (LVR) circuitry to hold the CPU in reset

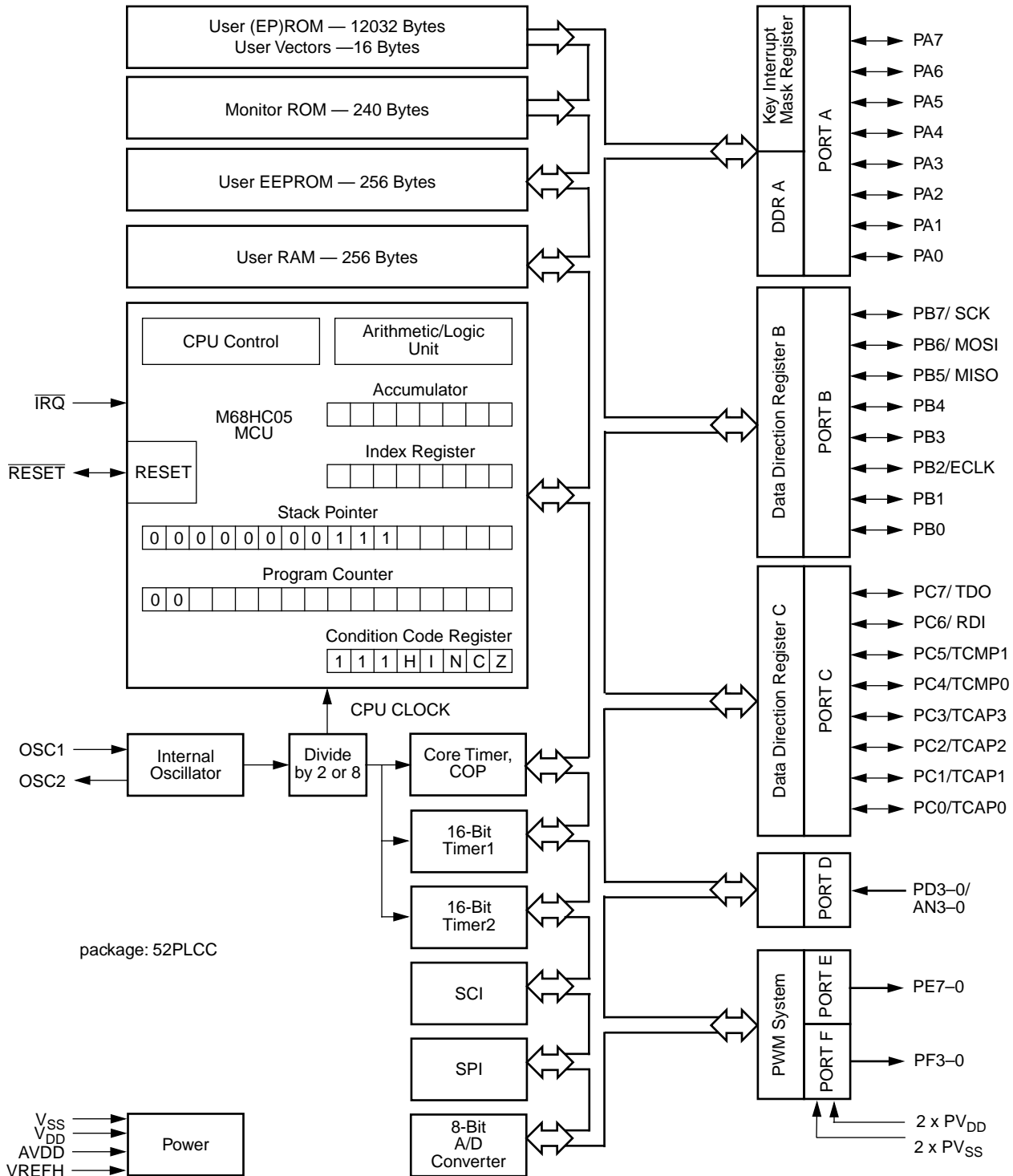


Figure 1-1. MC68HC(7)05H12 Block Diagram

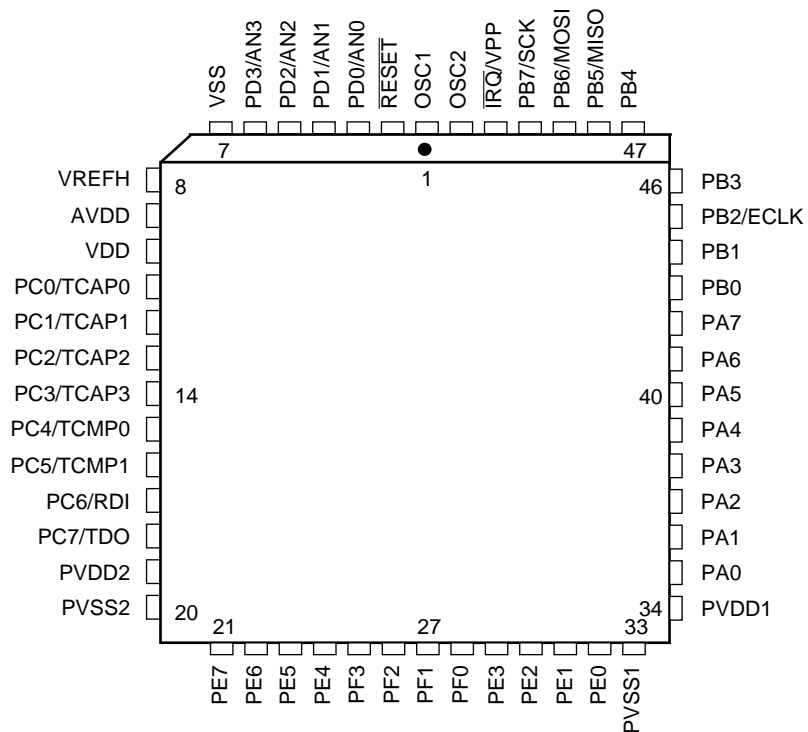
## 1.4 Mask Options

There are three mask options:

- COP watchdog timer (enable/disable)
- Low voltage reset (LVR) (enable/disable)
- Ports E/F in WAIT mode (enable/disable)

## 1.5 Pin Assignments

Figure 1-2 shows the PLCC pin assignments.



**Figure 1-2. MC68HC(7)05H12 Pin Assignments (52-pin PLCC package)**

## 1.6 Functional Pin Description

The following paragraphs give a description of the general function of each pin.

### 1.6.1 VDD and VSS

Power is supplied to the MCU through VDD and VSS. VDD is the positive supply, and VSS is ground.

### 1.6.2 AVDD

AVDD is a separate supply pin providing power to the A/D converter.

### 1.6.3 OSC1, OSC2

The OSC1 and OSC2 pins are the connections for the on-chip oscillator. A crystal connected across these pins or an external signal connected to OSC1 provides the oscillator clock. The frequency,  $f_{OSC}$ , of the oscillator or external clock source is divided by two or eight (slow mode) to produce the internal operating frequency,  $f_{OP}$ .

### 1.6.4 $\overline{RESET}$

This pin can be used as an input to reset the MCU to a known start-up state by pulling it to the low state. The  $\overline{RESET}$  pin contains an internal Schmitt trigger to improve its noise immunity as an input. The  $\overline{RESET}$  pin has an internal pulldown device that pulls the  $\overline{RESET}$  pin low when there is an internal COP watchdog reset, power-on reset (POR), illegal address reset, or an internal low voltage reset. Refer to **Section 5 Resets**. The  $\overline{RESET}$  pin contains an internal pullup device.

### 1.6.5 $\overline{IRQ}/VPP$

The interrupt triggering sensitivity of this pin can be programmed as falling edge sensitive or falling edge and low level sensitive. The  $\overline{IRQ}$  pin

contains an internal Schmitt trigger as part of its input to improve noise immunity. See **Section 4 Interrupts** for more details on the interrupts.

$\overline{\text{IRQ}}$ /VPP is also the EPROM programming power pin.

### 1.6.6 PA0–PA7/Keyboard Interrupt

These eight I/O lines comprise port A. The state of any pin is software programmable and all port A lines are configured as inputs during power-on or reset. The eight I/O lines are shared with the keyboard interrupt function. See **Section 7 Input/Output Ports** for more details on the I/O ports.

### 1.6.7 PB0–PB7/ECLK, MISO, MOSI, SCK

These eight I/O lines comprise port B. The state of any pin is software programmable and all port B lines are configured as inputs during power-on or reset. See **Section 7 Input/Output Ports** for more details on the I/O ports. The port pins PB5–PB7 are shared with the SPI system (MISO, MOSI, SCK). See **Section 10 Serial Peripheral Interface (SPI)** for more details on the operation of the SPI. Pin PB2 is shared with the internal system clock ECLK. See **Section 2.3.1 System Control Register**.

### 1.6.8 PC0–PC7/TCAP0–3, TCMP0–1, RDI, TDO

These eight I/O lines comprise port C. The state of any pin is software programmable and all port C lines are configured as inputs during power-on or reset. See **Section 7 Input/Output Ports** for more details on the I/O ports. The port pins PC0–PC5 are shared with the 16-bit timer (TCAP0–3, TCMP0–1). See **Section 9 16-Bit Timers** for more details on the operation of the 16-bit timers. The port pins PC6 and PC7 are shared with the SCI system (RDI and TDO). Refer to **Section 11 Serial Communications Interface (SCI)**.



### 1.6.9 PD0–PD3/AN0–AN3

These four input only lines comprise port D. See **Section 7 Input/Output Ports** for more details on the I/O ports. When the A/D converter is active, one of the 4 input lines may be selected by the A/D multiplexer for conversion. See **Section 12 Analog to Digital Converter** for more details on the operation of the A/D subsystem.

### 1.6.10 VREFH

This pin provides the positive reference voltage for the A/D converter. VSS provides the negative reference voltage for the A/D converter.

### 1.6.11 PE0–PE7

These eight output only lines comprise port E. See **Section 7 Input/Output Ports** for more details on the I/O ports. The eight lines are shared with four PWM H-bridge driver pairs. The outputs are formed by special power drivers. See **Section 14 Pulse Width Modulator (PWM)** for more details on the PWM subsystem.

### 1.6.12 PF0–PF3

These four output only lines comprise port F. See **Section 7 Input/Output Ports** for more details on the I/O ports. The four lines are shared with four PWM channels. The outputs are formed by special power drivers. See **Section 14 Pulse Width Modulator (PWM)** for more details on the PWM subsystem.

### 1.6.13 PVDD1, PVSS1, PVDD2, PVSS2

Power is supplied to the power drivers through PVDD and PVSS. PVDD1 and PVSS1 are the supply pins for PE0–3 and PF0–1 and PVDD2 and PVSS2 are the supply pins for PE4–7 and PF2–3.

The VSS pin and the PVSS1 and PVSS2 pins are connected internally.



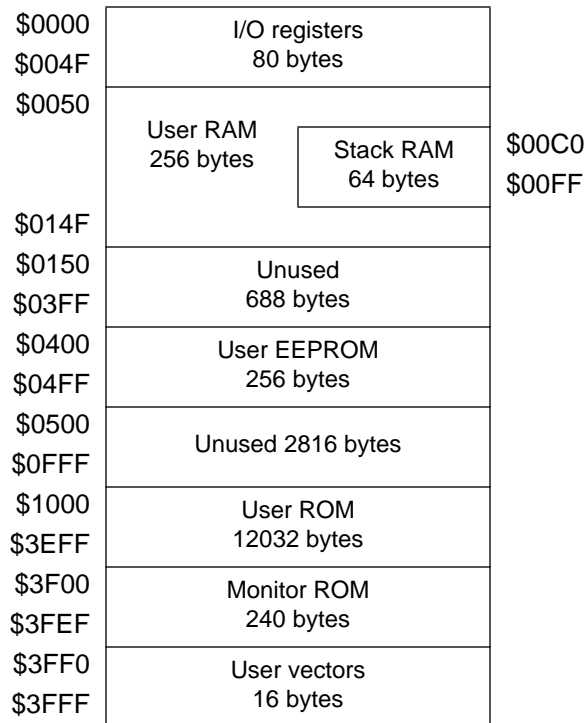
## Section 2. Memory

### 2.1 Contents

2.2	Introduction . . . . .	25
2.3	Registers . . . . .	26
2.3.1	System Control Register . . . . .	34
2.4	RAM . . . . .	35
2.5	ROM . . . . .	35
2.6	Monitor ROM . . . . .	35
2.7	User EPROM (for the 705 version only) . . . . .	35
2.8	EEPROM . . . . .	35

### 2.2 Introduction

The MC68HC(7)05H12 has a 16K byte memory map consisting of registers (for I/O, control and status), user RAM, user ROM (or EPROM), EEPROM, monitor ROM, and reset and interrupt vectors as shown in **Figure 2-1**.



**Figure 2-1. MC68HC(7)05H12 Memory Map**

## 2.3 Registers

The I/O and control registers reside in locations \$0000–\$004F. The overall organization of these registers is shown in **Figure 1-2**. The bit assignments for each register are shown in **Figure 2-3**, **Figure 2-4**, **Figure 2-5**, **Figure 2-6**, and **Figure 2-7**.

<b>Addr</b>	<b>Register Name</b>
\$0000	Port A Data Register
\$0001	Port B Data Register
\$0002	Port C Data Register
\$0003	Port D Data Register
\$0004	Port A Data Direction Register
\$0005	Port B Data Direction Register
\$0006	Port C Data Direction Register
\$0007	Port C Control Register
\$0008	Core Timer Control/Status (CTCSR)
\$0009	Core Timer Counter (CTCR)
\$000A	Unused
\$000B	Unused
\$000C	Unused
\$000D	Port A Interrupt Edge
\$000E	Port A Interrupt Control
\$000F	Port A Interrupt Status
\$0010	PWM Data 0
\$0011	PWM Data 1
\$0012	PWM Data 2
\$0013	PWM Data 3
\$0014	PWM Data 4
\$0015	PWM Data 5
\$0016	PWM Data 6
\$0017	PWM Data 7
\$0018	PWM Control/Sign
\$0019	PWM Channel Enable
\$001A	PWM Channel Polarity
\$001B	Unused
\$001C	EEPROM Control
\$001D	RESERVED for 705 version
\$001E	Unused
\$001F	TEST
\$0020	Timer1 Capture 1 High
\$0021	Timer1 Capture 1 Low
\$0022	Timer1 Compare 1 High
\$0023	Timer1 Compare 1 Low
\$0024	Timer1 Capture 2 High
\$0025	Timer1 Capture 2 Low
\$0026	Timer1 Compare 2 High

**Figure 2-2. I/O Register Summary**

Addr	Register Name
\$0027	Timer1 Compare 2 Low
\$0028	Timer1 Counter High
\$0029	Timer1 Counter Low
\$002A	Timer1 Alternate Counter High
\$002B	Timer1 Alternate Counter Low
\$002C	Timer1 Control 1
\$002D	Timer1 Control 2
\$002E	Timer1 Status
\$002F	Unused
\$0030	Timer2 Capture 1 High
\$0031	Timer2 Capture 1 Low
\$0032	Timer2 Compare 1 High
\$0033	Timer2 Compare 1 Low
\$0034	Timer2 Capture 2 High
\$0035	Timer2 Capture 2 Low
\$0036	Timer2 Compare 2 High
\$0037	Timer2 Compare 2 Low
\$0038	Timer2 Counter High
\$0039	Timer2 Counter Low
\$003A	Timer2 Alternate Counter High
\$003B	Timer2 Alternate Counter Low
\$003C	Timer2 Control 1
\$003D	Timer2 Control 2
\$003E	Timer2 Status
\$003F	Unused
\$0040	Port E Data Register
\$0041	Port E Mismatch Register
\$0042	Port F Data Register
\$0043	Port F Mismatch Register
\$0044	SPI Control
\$0045	SPI Status
\$0046	SPI Data I/O
\$0047	SCI SCDAT
\$0048	SCI SCCR1
\$0049	SCI SCCR2
\$004A	SCI SCSR
\$004B	SCI BAUD
\$004C	Unused
\$004D	System Control Register
\$004E	A/D DATA
\$004F	A/D STATUS/CTL

**Figure 2-2. I/O Register Summary**

Addr	Register	R/W	Bit 7	Bit 6	Bit 5	Bit 4	Bit 3	Bit 2	Bit 1	Bit 0
\$0000	Port A Data	R W	PA7	PA6	PA5	PA4	PA3	PA2	PA1	PA0
\$0001	Port B Data	R W	PB7	PB6	PB5	PB4	PB3	PB2	PB1	PB0
\$0002	Port C Data	R W	PC7	PC6	PC5	PC4	PC3	PC2	PC1	PC0
\$0003	Port D Data	R W	0	0	0	0	PD3	PD2	PD1	PD0
\$0004	Port A Data Direction	R W	DDRA7	DDRA6	DDRA5	DDRA4	DDRA3	DDRA2	DDRA1	DDRA0
\$0005	Port B Data Direction	R W	DDRB7	DDRB6	DDRB5	DDRB4	DDRB3	DDRB2	DDRB1	DDRB0
\$0006	Port C Data Direction	R W	DDRC7	DDRC6	DDRC5	DDRC4	DDRC3	DDRC2	DDRC1	DDRC0
\$0007	Port C Control	R W	0	0	TCMP1	TCMP0	0	0	0	0
\$0008	CTSCR	R W	TOF	RTIF	TOFE	RTIE	0 RTOF	0 RTIF	RT1	RT0
\$0009	CTCR	R W	bit 7	bit 6	bit 5	bit 4	bit 3	bit 2	bit 1	bit 0
\$000A	Unimplemented	R W								
\$000B	Unimplemented	R W								
\$000C	Unimplemented	R W								
\$000D	PAIED	R W	EDGE7	EDGE6	EDGE5	EDGE4	EDGE3	EDGE2	EDGE1	EDGE0
\$000E	PAICR	R W	PAIE7	PAIE6	PAIE5	PAIE4	PAIE3	PAIE2	PAIE1	PAIE0
\$000F	PAISR	R W	PAIF7	PAIF6	PAIF5	PAIF4	PAIF3	PAIF2	PAIF1	PAIF0

**Figure 2-3. I/O Registers \$0000–\$000F**

# Memory

Addr	Register	R/W	Bit 7	Bit 6	Bit 5	Bit 4	Bit 3	Bit 2	Bit 1	Bit 0
\$0010	PWM Data 0	R W	bit 7	bit 6	bit 5	bit 4	bit 3	bit 2	bit 1	bit 0
\$0011	PWM Data 1	R W	bit 7	bit 6	bit 5	bit 4	bit 3	bit 2	bit 1	bit 0
\$0012	PWM Data 2	R W	bit 7	bit 6	bit 5	bit 4	bit 3	bit 2	bit 1	bit 0
\$0013	PWM Data 3	R W	bit 7	bit 6	bit 5	bit 4	bit 3	bit 2	bit 1	bit 0
\$0014	PWM Data 4	R W	bit 7	bit 6	bit 5	bit 4	bit 3	bit 2	bit 1	bit 0
\$0015	PWM Data 5	R W	bit 7	bit 6	bit 5	bit 4	bit 3	bit 2	bit 1	bit 0
\$0016	PWM Data 6	R W	bit 7	bit 6	bit 5	bit 4	bit 3	bit 2	bit 1	bit 0
\$0017	PWM Data 7	R W	bit 7	bit 6	bit 5	bit 4	bit 3	bit 2	bit 1	bit 0
\$0018	PWMCTL	R W	0 PWMRS	PWMC3	PWMC2	PWMC1	SIGN3	SIGN2	SIGN1	SIGN0
\$0019	PWMEN	R W	PWME7	PWME6	PWME5	PWME4	PWME3	PWME2	PWME1	PWME0
\$001A	PWMPOL	R W	PPOL7	PPOL6	PPOL5	PPOL4	PPOL3	PPOL2	PPOL1	PPOL0
\$001B	Unimplemented	R W								
\$001C	EEPCR	R W	0	0	0	EEOSC	ER1	EER0	EELAT	EEPGM
\$001D	Reserved for 705 version	R W								
\$001E	Unimplemented	R W								
\$001F	TEST	R W	0 +++++	0 +++++	0 +++++	0 +++++	0 +++++	0 +++++	0 +++++	0 +++++

**Figure 2-4. I/O Registers \$0010–\$001F**



Addr	Register	R/W	Bit 7	Bit 6	Bit 5	Bit 4	Bit 3	Bit 2	Bit 1	Bit 0
\$0020	Timer 1 Input Capture1 High	R	bit 15	bit 14	bit 13	bit 12	bit 11	bit 10	bit 9	bit 8
		W								
\$0021	Timer 1 Input Capture1 Low	R	bit 7	bit 6	bit 5	bit 4	bit 3	bit 2	bit 1	bit 0
		W								
\$0022	Timer 1 Output Compare1 High	R	bit 15	bit 14	bit 13	bit 12	bit 11	bit 10	bit 9	bit 8
		W								
\$0023	Timer 1 Output Compare1 Low	R	bit 7	bit 6	bit 5	bit 4	bit 3	bit 2	bit 1	bit 0
		W								
\$0024	Timer 1 Input Capture2 High	R	bit 15	bit 14	bit 13	bit 12	bit 11	bit 10	bit 9	bit 8
		W								
\$0025	Timer 1 Input Capture2 Low	R	bit 7	bit 6	bit 5	bit 4	bit 3	bit 2	bit 1	bit 0
		W								
\$0026	Timer 1 Output Compare2 High	R	bit 15	bit 14	bit 13	bit 12	bit 11	bit 10	bit 9	bit 8
		W								
\$0027	Timer 1 Output Compare2 Low	R	bit 7	bit 6	bit 5	bit 4	bit 3	bit 2	bit 1	bit 0
		W								
\$0028	Timer 1 Counter High	R	bit 15	bit 14	bit 13	bit 12	bit 11	bit 10	bit 9	bit 8
		W								
\$0029	Timer 1 Counter Low	R	bit 7	bit 6	bit 5	bit 4	bit 3	bit 2	bit 1	bit 0
		W								
\$002A	Timer 1 Alternate Counter High	R	bit 15	bit 14	bit 13	bit 12	bit 11	bit 10	bit 9	bit 8
		W								
\$002B	Timer 1 Alternate Counter Low	R	bit 7	bit 6	bit 5	bit 4	bit 3	bit 2	bit 1	bit 0
		W								
\$002C	Timer 1 Control 1	R	IC1E	IC2E	OC1E	TOIE	CO1E	IEDG1	IEDG2	OLVL1
		W								
\$002D	Timer 1 Control 2	R	0	0	OC2E	0	CO2E	0	0	OLVL2
		W								
\$002E	Timer 1 Status	R	IC1F	IC2F	OC1F	TOF	TCAP1	TCAP2	OC2F	0
		W								
\$002F	Unimplemented	R								
		W								

**Figure 2-5. I/O Registers \$0020–\$002F**

# Memory

Addr	Register	R/W	Bit 7	Bit 6	Bit 5	Bit 4	Bit 3	Bit 2	Bit 1	Bit 0
\$0030	Timer 2 Input Capture1 High	R	bit 15	bit 14	bit 13	bit 12	bit 11	bit 10	bit 9	bit 8
		W								
\$0031	Timer 2 Input Capture1 Low	R	bit 7	bit 6	bit 5	bit 4	bit 3	bit 2	bit 1	bit 0
		W								
\$0032	Timer 2 Output Compare1 High	R	bit 15	bit 14	bit 13	bit 12	bit 11	bit 10	bit 9	bit 8
		W								
\$0033	Timer 2 Output Compare1 Low	R	bit 7	bit 6	bit 5	bit 4	bit 3	bit 2	bit 1	bit 0
		W								
\$0034	Timer 2 Input Capture2 High	R	bit 15	bit 14	bit 13	bit 12	bit 11	bit 10	bit 9	bit 8
		W								
\$0035	Timer 2 Input Capture2 Low	R	bit 7	bit 6	bit 5	bit 4	bit 3	bit 2	bit 1	bit 0
		W								
\$0036	Timer 2 Output Compare2 High	R	bit 15	bit 14	bit 13	bit 12	bit 11	bit 10	bit 9	bit 8
		W								
\$0037	Timer 2 Output Compare2 Low	R	bit 7	bit 6	bit 5	bit 4	bit 3	bit 2	bit 1	bit 0
		W								
\$0038	Timer 2 Counter High	R	bit 15	bit 14	bit 13	bit 12	bit 11	bit 10	bit 9	bit 8
		W								
\$0039	Timer 2 Counter Low	R	bit 7	bit 6	bit 5	bit 4	bit 3	bit 2	bit 1	bit 0
		W								
\$003A	Timer 2 Alternate Counter High	R	bit 15	bit 14	bit 13	bit 12	bit 11	bit 10	bit 9	bit 8
		W								
\$003B	Timer 2 Alternate Counter Low	R	bit 7	bit 6	bit 5	bit 4	bit 3	bit 2	bit 1	bit 0
		W								
\$003C	Timer 2 Control 1	R	IC1E	IC2E	OC1E	TOIE	CO1E	IEDG1	IEDG2	OLVL1
		W								
\$003D	Timer 2 Control 2	R	0	0	OC2E	0	CO2E	0	0	OLVL2
		W								
\$003E	Timer 2 Status	R	IC1F	IC2F	OC1F	TOF	TCAP1	TCAP2	OC2F	0
		W								
\$003F	Unimplemented	R								
		W								

**Figure 2-6. I/O Registers \$0030–\$003F**

Addr	Register	R/W	Bit 7	Bit 6	Bit 5	Bit 4	Bit 3	Bit 2	Bit 1	Bit 0
\$0040	Port E Data	R W	PE7	PE6	PE5	PE4	PE3	PE2	PE1	PE0
\$0041	Port E Mismatch	R W	bit 7	bit 6	bit 5	bit 4	bit 3	bit 2	bit 1	bit 0
\$0042	Port F Data	R W	0	0	0	0	PF3	PF2	PF1	PF0
\$0043	Port F Mismatch	R W	0	0	0	0	bit 3	bit 2	bit 1	bit 0
\$0044	SPI Control	R W	SPIE	SPE	DOD	MSTR	CPOL	CPHA	SPR1	SPR0
\$0045	SPI Status	R W	SPIF	WCOL	0	0	0	0	0	0
\$0046	SPI Data	R W	bit 7	bit 6	bit 5	bit 4	bit 3	bit 2	bit 1	bit 0
\$0047	SCI Data	R W	bit 7	bit 6	bit 5	bit 4	bit 3	bit 2	bit 1	bit 0
\$0048	SCI Control 1	R W	R8	T8	0	M	WAKE	0	0	0
\$0049	SCI Control 2	R W	TIE	TCIE	RIE	ILIE	TE	RE	RWU	SBK
\$004A	SCI Status	R W	TDRE	TC	RDRF	IDLE	OR	NF	FE	0
\$004B	SCI BAUD	R W	0 TCLR	SPP	SCP1	SCP0	0 RCKB	SCR2	SCR1	SCR0
\$004C	Unimplemented	R W								
\$004D	System Control	R W	0	0	0	SC	IRQ	0	0	ECLK
\$004E	A/D Data	R W	bit 7	bit 6	bit 5	bit 4	bit 3	bit 2	bit 1	bit 0
\$004F	A/D Status/Control	R W	COCO	ADRC	ADON	0	CH3	CH2	CH1	CH0

Figure 2-7. I/O Registers \$0040–\$004F

## 2.3.1 System Control Register

The MC68HC(7)05H12 contains a system control register which is located at \$004D. This register is used to control the IRQ interrupt sensitivity, the bus frequency, and the external availability of the internal bus clock.

\$004D	Bit 7	6	5	4	3	2	1	Bit 0
Read:	0	0	0	SC	IRQ	0	0	ECLK
Write:								
Reset:	0	0	0	0	0	0	0	0

**Figure 2-8. System Control Register (SYSCR)**

### SC — System Clock Option

After power on reset the internal bus frequency  $f_{OP}$  is  $= f_{OSC}/2$ . The SC bit allows the user to reduce the system speed to  $f_{OSC}/8$ .

1 =  $f_{OP} = f_{OSC}/8$  (Slow Mode)

0 =  $f_{OP} = f_{OSC}/2$

### IRQ — IRQ Sensitivity

IRQ edge or level sensitive

1 = IRQ input edge and level sensitive

0 = IRQ input edge sensitive

### ECLK — Internal System Clock Available

The ECLK bit makes the internal system clock (bus frequency  $f_{OP}$ ) available to the user. Refer to **Section 7.4 Port B** for more details.

1 = The PB2/ECLK pin provides the internal system clock

independently of the value of the port B data direction register

0 = The internal system clock is not available, the PB2/ECLK pin is an ordinary I/O port line

## 2.4 RAM

The user RAM consists of 256 bytes ranging from \$0050 to \$014F. The stack begins at address \$00FF. The stack pointer can access 64 bytes of RAM in the range \$00FF to \$00C0.

The stack is located in the middle of the RAM address space. Data written to addresses within the stack address range could be overwritten during stack activity.

## 2.5 ROM

The 12032 bytes of the user ROM are located from \$1000 to \$3EFF, plus 16 bytes of user vectors from \$3FF0 to \$3FFF.

## 2.6 Monitor ROM

The monitor ROM ranges from \$3F00 to \$3FEF. The vectors for the bootloader are located from \$3FE0 to \$3FEF.

## 2.7 User EPROM (for the 705 version only)

The 12032 bytes of the user EPROM are located from \$1000 to \$3EFD, including two bytes of mask option registers (MOR) at \$3EFE and \$3EFF, plus 16 bytes of user vectors from \$3FF0 to \$3FFF. Refer to **Section 15 EPROM** for programming details.

## 2.8 EEPROM

This device contains 256 bytes of EEPROM. Programming the EEPROM is performed by the user on a single-byte basis by manipulating the EEPROM control register, located at address \$001C. Refer to **Section 13 EEPROM** for programming details.



## Section 3. CPU and Instruction Set

### 3.1 Contents

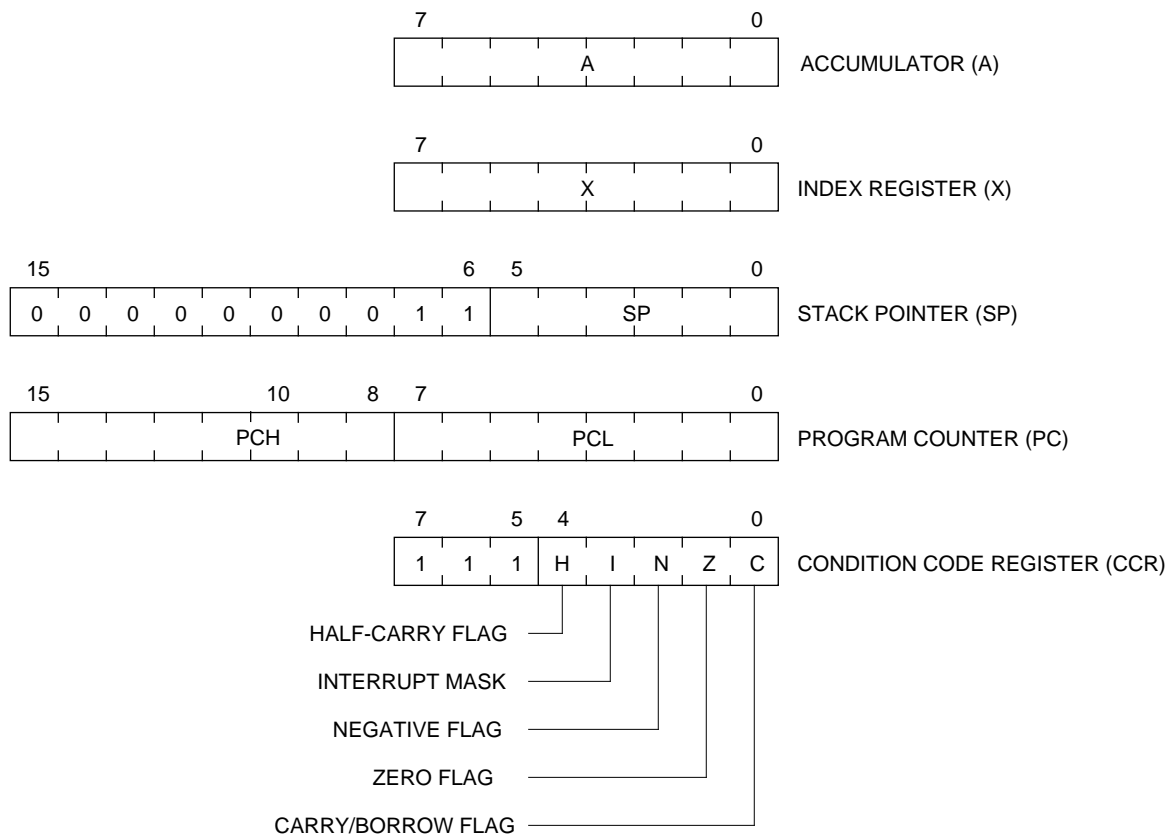
3.2	Introduction . . . . .	38
3.3	CPU Registers . . . . .	38
3.3.1	Accumulator . . . . .	39
3.3.2	Index Register . . . . .	39
3.3.3	Stack Pointer . . . . .	39
3.3.4	Program Counter . . . . .	40
3.3.5	Condition Code Register . . . . .	40
3.4	Arithmetic/Logic Unit (ALU) . . . . .	42
3.5	Instruction Set Overview . . . . .	42
3.6	Addressing Modes . . . . .	42
3.6.1	Inherent . . . . .	43
3.6.2	Immediate . . . . .	43
3.6.3	Direct . . . . .	43
3.6.4	Extended . . . . .	43
3.6.5	Indexed, No Offset . . . . .	44
3.6.6	Indexed, 8-Bit Offset . . . . .	44
3.6.7	Indexed, 16-Bit Offset . . . . .	44
3.6.8	Relative . . . . .	45
3.7	Instruction Types . . . . .	45
3.7.1	Register/Memory Instructions . . . . .	46
3.7.2	Read-Modify-Write Instructions . . . . .	47
3.7.3	Jump/Branch Instructions . . . . .	48
3.7.4	Bit Manipulation Instructions . . . . .	50
3.7.5	Control Instructions . . . . .	51
3.8	Instruction Set Summary . . . . .	52

## 3.2 Introduction

This chapter describes the CPU registers and the HC05 instruction set.

## 3.3 CPU Registers

**Figure 3-1** shows the five CPU registers. CPU registers are not part of the memory map.

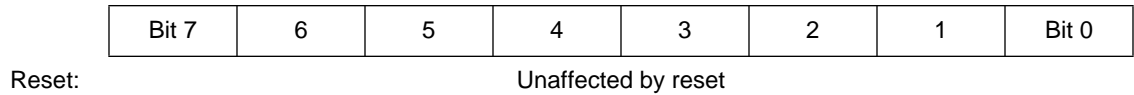


**Figure 3-1. Programming Model**



### 3.3.1 Accumulator

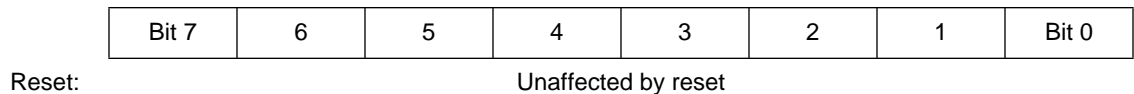
The accumulator is a general-purpose 8-bit register. The CPU uses the accumulator to hold operands and results of arithmetic and non-arithmetic operations.



**Figure 3-2. Accumulator**

### 3.3.2 Index Register

In the indexed addressing modes, the CPU uses the byte in the index register to determine the conditional address of the operand.

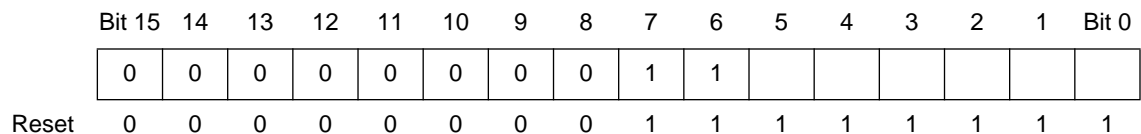


**Figure 3-3. Index Register**

The 8-bit index register can also serve as a temporary data storage location.

### 3.3.3 Stack Pointer

The stack pointer is a 16-bit register that contains the address of the next location on the stack. During a reset or after the reset stack pointer (RSP) instruction, the stack pointer is preset to \$00FF. The address in the stack pointer decrements as data is pushed onto the stack and increments as data is pulled from the stack.



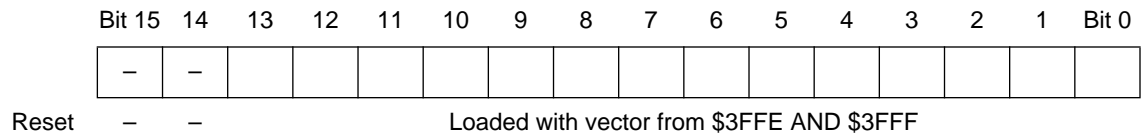
**Figure 3-4. Stack Pointer**

The ten most significant bits of the stack pointer are permanently fixed at 00000011, so the stack pointer produces addresses from \$00C0 to \$00FF. If subroutines and interrupts use more than 64 stack locations, the stack pointer wraps around to address \$00FF and begins writing over the previously stored data. A subroutine uses two stack locations. An interrupt uses five locations.

### 3.3.4 Program Counter

The program counter is a 16-bit register that contains the address of the next instruction or operand to be fetched. The two most significant bits of the program counter are ignored internally.

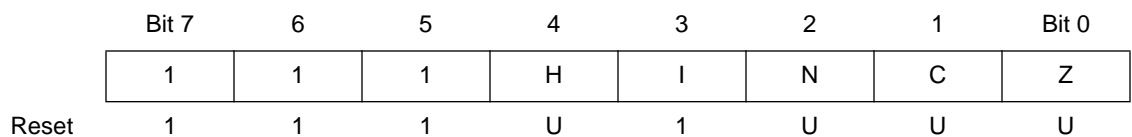
Normally, the address in the program counter automatically increments to the next sequential memory location every time an instruction or operand is fetched. Jump, branch, and interrupt operations load the program counter with an address other than that of the next sequential location.



**Figure 3-5. Program Counter**

### 3.3.5 Condition Code Register

The condition code register is an 8-bit register whose three most significant bits are permanently fixed at 111. The condition code register contains the interrupt mask and four flags that indicate the results of the instruction just executed. The following paragraphs describe the functions of the condition code register.



**Figure 3-6. Condition Code Register**

### **Half-Carry Flag**

The CPU sets the half-carry flag when a carry occurs between bits 3 and 4 of the accumulator during an ADD or ADC operation. The half-carry flag is required for binary-coded decimal (BCD) arithmetic operations.

### **Interrupt Mask**

Setting the interrupt mask disables interrupts. If an interrupt request occurs while the interrupt mask is logic zero, the CPU saves the CPU registers on the stack, sets the interrupt mask, and then fetches the interrupt vector. If an interrupt request occurs while the interrupt mask is set, the interrupt request is latched. Normally, the CPU processes the latched interrupt as soon as the interrupt mask is cleared again.

A return from interrupt (RTI) instruction pulls the CPU registers from the stack, restoring the interrupt mask to its cleared state. After any reset, the interrupt mask is set and can be cleared only by a software instruction.

### **Negative Flag**

The CPU sets the negative flag when an arithmetic operation, logical operation, or data manipulation produces a negative result.

### **Zero Flag**

The CPU sets the zero flag when an arithmetic operation, logical operation, or data manipulation produces a result of \$00.

### **Carry/Borrow Flag**

The CPU sets the carry/borrow flag when an addition operation produces a carry out of bit 7 of the accumulator or when a subtraction operation requires a borrow. Some logical operations and data manipulation instructions also clear or set the carry/borrow flag.

### 3.4 Arithmetic/Logic Unit (ALU)

The ALU performs the arithmetic and logical operations defined by the instruction set.

The binary arithmetic circuits decode instructions and set up the ALU for the selected operation. Most binary arithmetic is based on the addition algorithm, carrying out subtraction as negative addition. Multiplication is not performed as a discrete operation but as a chain of addition and shift operations within the ALU. The multiply instruction (MUL) requires 11 internal clock cycles to complete this chain of operations.

### 3.5 Instruction Set Overview

The MCU instruction set has 62 instructions and uses eight addressing modes. The instructions include all those of the M146805 CMOS Family plus one more: the unsigned multiply (MUL) instruction. The MUL instruction allows unsigned multiplication of the contents of the accumulator (A) and the index register (X). The high-order product is stored in the index register, and the low-order product is stored in the accumulator.

### 3.6 Addressing Modes

The CPU uses eight addressing modes for flexibility in accessing data. The addressing modes provide eight different ways for the CPU to find the data required to execute an instruction. The eight addressing modes are:

- Inherent
- Immediate
- Direct
- Extended
- Indexed, no offset
- Indexed, 8-bit offset

- Indexed, 16-bit offset
- Relative

### 3.6.1 Inherent

Inherent instructions are those that have no operand, such as return from interrupt (RTI). Some of the inherent instructions act on data in the CPU registers, such as set carry flag (SEC) and increment accumulator (INCA). Inherent instructions require no operand address and are one byte long.

### 3.6.2 Immediate

Immediate instructions are those that contain a value to be used in an operation with the value in the accumulator or index register. Immediate instructions require no operand address and are two bytes long. The opcode is the first byte, and the immediate data value is the second byte.

### 3.6.3 Direct

Direct instructions can access any of the first 256 memory locations with two bytes. The first byte is the opcode, and the second is the low byte of the operand address. In direct addressing, the CPU automatically uses \$00 as the high byte of the operand address.

### 3.6.4 Extended

Extended instructions use three bytes and can access any address in memory. The first byte is the opcode; the second and third bytes are the high and low bytes of the operand address.

When using the Motorola assembler, the programmer does not need to specify whether an instruction is direct or extended. The assembler automatically selects the shortest form of the instruction.

### 3.6.5 Indexed, No Offset

Indexed instructions with no offset are 1-byte instructions that can access data with variable addresses within the first 256 memory locations. The index register contains the low byte of the effective address of the operand. The CPU automatically uses \$00 as the high byte, so these instructions can address locations \$0000–\$00FF.

Indexed, no offset instructions are often used to move a pointer through a table or to hold the address of a frequently used RAM or I/O location.

### 3.6.6 Indexed, 8-Bit Offset

Indexed, 8-bit offset instructions are 2-byte instructions that can access data with variable addresses within the first 511 memory locations. The CPU adds the unsigned byte in the index register to the unsigned byte following the opcode. The sum is the effective address of the operand. These instructions can access locations \$0000–\$01FE.

Indexed 8-bit offset instructions are useful for selecting the *k*th element in an *n*-element table. The table can begin anywhere within the first 256 memory locations and could extend as far as location 510 (\$01FE). The *k* value is typically in the index register, and the address of the beginning of the table is in the byte following the opcode.

### 3.6.7 Indexed, 16-Bit Offset

Indexed, 16-bit offset instructions are 3-byte instructions that can access data with variable addresses at any location in memory. The CPU adds the unsigned byte in the index register to the two unsigned bytes following the opcode. The sum is the effective address of the operand. The first byte after the opcode is the high byte of the 16-bit offset; the second byte is the low byte of the offset.

Indexed, 16-bit offset instructions are useful for selecting the *k*th element in an *n*-element table anywhere in memory.

As with direct and extended addressing, the Motorola assembler determines the shortest form of indexed addressing.

### 3.6.8 Relative

Relative addressing is only for branch instructions. If the branch condition is true, the CPU finds the effective branch destination by adding the signed byte following the opcode to the contents of the program counter. If the branch condition is not true, the CPU goes to the next instruction. The offset is a signed, two's complement byte that gives a branching range of  $-128$  to  $+127$  bytes from the address of the next location after the branch instruction.

When using the Motorola assembler, the programmer does not need to calculate the offset, because the assembler determines the proper offset and verifies that it is within the span of the branch.

## 3.7 Instruction Types

The MCU instructions fall into the following five categories:

- Register/Memory Instructions
- Read-Modify-Write Instructions
- Jump/Branch Instructions
- Bit Manipulation Instructions
- Control Instructions

### 3.7.1 Register/Memory Instructions

These instructions operate on CPU registers and memory locations. Most of them use two operands. One operand is in either the accumulator or the index register. The CPU finds the other operand in memory.

**Table 3-1. Register/Memory Instructions**

<b>Instruction</b>	<b>Mnemonic</b>
Add Memory Byte and Carry Bit to Accumulator	ADC
Add Memory Byte to Accumulator	ADD
AND Memory Byte with Accumulator	AND
Bit Test Accumulator	BIT
Compare Accumulator	CMP
Compare Index Register with Memory Byte	CPX
EXCLUSIVE OR Accumulator with Memory Byte	EOR
Load Accumulator with Memory Byte	LDA
Load Index Register with Memory Byte	LDX
Multiply	MUL
OR Accumulator with Memory Byte	ORA
Subtract Memory Byte and Carry Bit from Accumulator	SBC
Store Accumulator in Memory	STA
Store Index Register in Memory	STX
Subtract Memory Byte from Accumulator	SUB



### 3.7.2 Read-Modify-Write Instructions

These instructions read a memory location or a register, modify its contents, and write the modified value back to the memory location or to the register.

**NOTE:** *Do not use read-modify-write operations on write-only registers.*

**Table 3-2. Read-Modify-Write Instructions**

Instruction	Mnemonic
Arithmetic Shift Left (Same as LSL)	ASL
Arithmetic Shift Right	ASR
Bit Clear	BCLR <sup>(1)</sup>
Bit Set	BSET <sup>(1)</sup>
Clear Register	CLR
Complement (One's Complement)	COM
Decrement	DEC
Increment	INC
Logical Shift Left (Same as ASL)	LSL
Logical Shift Right	LSR
Negate (Two's Complement)	NEG
Rotate Left through Carry Bit	ROL
Rotate Right through Carry Bit	ROR
Test for Negative or Zero	TST <sup>(2)</sup>

1. Unlike other read-modify-write instructions, BCLR and BSET use only direct addressing.
2. TST is an exception to the read-modify-write sequence because it does not write a replacement value.

### 3.7.3 Jump/Branch Instructions

Jump instructions allow the CPU to interrupt the normal sequence of the program counter. The unconditional jump instruction (JMP) and the jump-to-subroutine instruction (JSR) have no register operand. Branch instructions allow the CPU to interrupt the normal sequence of the program counter when a test condition is met. If the test condition is not met, the branch is not performed.

The BRCLR and BRSET instructions cause a branch based on the state of any readable bit in the first 256 memory locations. These 3-byte instructions use a combination of direct addressing and relative addressing. The direct address of the byte to be tested is in the byte following the opcode. The third byte is the signed offset byte. The CPU finds the effective branch destination by adding the third byte to the program counter if the specified bit tests true. The bit to be tested and its condition (set or clear) is part of the opcode. The span of branching is from  $-128$  to  $+127$  from the address of the next location after the branch instruction. The CPU also transfers the tested bit to the carry/borrow bit of the condition code register.

**Table 3-3. Jump and Branch Instructions**

<b>Instruction</b>	<b>Mnemonic</b>
Branch if Carry Bit Clear	BCC
Branch if Carry Bit Set	BCS
Branch if Equal	BEQ
Branch if Half-Carry Bit Clear	BHCC
Branch if Half-Carry Bit Set	BHCS
Branch if Higher	BHI
Branch if Higher or Same	BHS
Branch if $\overline{\text{IRQ}}$ Pin High	BIH
Branch if $\overline{\text{IRQ}}$ Pin Low	BIL
Branch if Lower	BLO
Branch if Lower or Same	BLS
Branch if Interrupt Mask Clear	BMC
Branch if Minus	BMI
Branch if Interrupt Mask Set	BMS
Branch if Not Equal	BNE
Branch if Plus	BPL
Branch Always	BRA
Branch if Bit Clear	BRCLR
Branch Never	BRN
Branch if Bit Set	BRSET
Branch to Subroutine	BSR
Unconditional Jump	JMP
Jump to Subroutine	JSR

## 3.7.4 Bit Manipulation Instructions

The CPU can set or clear any writable bit in the first 256 bytes of memory, which includes I/O registers and on-chip RAM locations. The CPU can also test and branch based on the state of any bit in any of the first 256 memory locations.

**Table 3-4. Bit Manipulation Instructions**

<b>Instruction</b>	<b>Mnemonic</b>
Bit Clear	BCLR
Branch if Bit Clear	BRCLR
Branch if Bit Set	BRSET
Bit Set	BSET

### 3.7.5 Control Instructions

These instructions act on CPU registers and control CPU operation during program execution.

**Table 3-5. Control Instructions**

<b>Instruction</b>	<b>Mnemonic</b>
Clear Carry Bit	CLC
Clear Interrupt Mask	CLI
No Operation	NOP
Reset Stack Pointer	RSP
Return from Interrupt	RTI
Return from Subroutine	RTS
Set Carry Bit	SEC
Set Interrupt Mask	SEI
Software Interrupt	SWI
Transfer Accumulator to Index Register	TAX
Transfer Index Register to Accumulator	TXA
Stop CPU Clock and Enable Interrupts	WAIT

## 3.8 Instruction Set Summary

Table 3-6. Instruction Set Summary

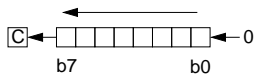
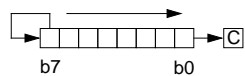
Source Form	Operation	Description	Effect on CCR					Address Mode	Opcode	Operand	Cycles
			H	I	N	Z	C				
ADC #opr ADC opr ADC opr ADC opr,X ADC opr,X ADC ,X	Add with Carry	$A \leftarrow (A) + (M) + (C)$	↕	—	↕	↕	↕	IMM DIR EXT IX2 IX1 IX	A9 B9 C9 D9 E9 F9	ii dd hh ll ee ff ff ff	2 3 4 5 4 3
ADD #opr ADD opr ADD opr ADD opr,X ADD opr,X ADD ,X	Add without Carry	$A \leftarrow (A) + (M)$	↕	—	↕	↕	↕	IMM DIR EXT IX2 IX1 IX	AB BB CB DB EB FB	ii dd hh ll ee ff ff ff	2 3 4 5 4 3
AND #opr AND opr AND opr AND opr,X AND opr,X AND ,X	Logical AND	$A \leftarrow (A) \wedge (M)$	—	—	↕	↕	—	IMM DIR EXT IX2 IX1 IX	A4 B4 C4 D4 E4 F4	ii dd hh ll ee ff ff ff	2 3 4 5 4 3
ASL opr ASLA ASLX ASL opr,X ASL ,X	Arithmetic Shift Left (Same as LSL)		—	—	↕	↕	↕	DIR INH INH IX1 IX	38 48 58 68 78	dd ff ff	5 3 3 6 5
ASR opr ASRA ASRX ASR opr,X ASR ,X	Arithmetic Shift Right		—	—	↕	↕	↕	DIR INH INH IX1 IX	37 47 57 67 77	dd ff ff	5 3 3 6 5
BCC rel	Branch if Carry Bit Clear	$PC \leftarrow (PC) + 2 + rel ? C = 0$	—	—	—	—	—	REL	24	rr	3
BCLR n opr	Clear Bit n	$M_n \leftarrow 0$	—	—	—	—	—	DIR (b0) DIR (b1) DIR (b2) DIR (b3) DIR (b4) DIR (b5) DIR (b6) DIR (b7)	11 13 15 17 19 1B 1D 1F	dd dd dd dd dd dd dd dd	5 5 5 5 5 5 5 5
BCS rel	Branch if Carry Bit Set (Same as BLO)	$PC \leftarrow (PC) + 2 + rel ? C = 1$	—	—	—	—	—	REL	25	rr	3
BEQ rel	Branch if Equal	$PC \leftarrow (PC) + 2 + rel ? Z = 1$	—	—	—	—	—	REL	27	rr	3
BHCC rel	Branch if Half-Carry Bit Clear	$PC \leftarrow (PC) + 2 + rel ? H = 0$	—	—	—	—	—	REL	28	rr	3
BHCS rel	Branch if Half-Carry Bit Set	$PC \leftarrow (PC) + 2 + rel ? H = 1$	—	—	—	—	—	REL	29	rr	3
BHI rel	Branch if Higher	$PC \leftarrow (PC) + 2 + rel ? C \vee Z = 0$	—	—	—	—	—	REL	22	rr	3
BHS rel	Branch if Higher or Same	$PC \leftarrow (PC) + 2 + rel ? C = 0$	—	—	—	—	—	REL	24	rr	3

Table 3-6. Instruction Set Summary (Continued)

Source Form	Operation	Description	Effect on CCR					Address Mode	Opcode	Operand	Cycles
			H	I	N	Z	C				
BIH <i>rel</i>	Branch if IRQ Pin High	$PC \leftarrow (PC) + 2 + rel ? IRQ = 1$	—	—	—	—	—	REL	2F	rr	3
BIL <i>rel</i>	Branch if IRQ Pin Low	$PC \leftarrow (PC) + 2 + rel ? IRQ = 0$	—	—	—	—	—	REL	2E	rr	3
BIT # <i>opr</i> BIT <i>opr</i> BIT <i>opr</i> BIT <i>opr</i> ,X BIT <i>opr</i> ,X BIT ,X	Bit Test Accumulator with Memory Byte	$(A) \wedge (M)$	—	—	↕	↕	—	IMM DIR EXT IX2 IX1 IX	A5 B5 C5 D5 E5 F5	ii dd hh ll ee ff ff	2 3 4 5 4 3
BLO <i>rel</i>	Branch if Lower (Same as BCS)	$PC \leftarrow (PC) + 2 + rel ? C = 1$	—	—	—	—	—	REL	25	rr	3
BLS <i>rel</i>	Branch if Lower or Same	$PC \leftarrow (PC) + 2 + rel ? C \vee Z = 1$	—	—	—	—	—	REL	23	rr	3
BMC <i>rel</i>	Branch if Interrupt Mask Clear	$PC \leftarrow (PC) + 2 + rel ? I = 0$	—	—	—	—	—	REL	2C	rr	3
BMI <i>rel</i>	Branch if Minus	$PC \leftarrow (PC) + 2 + rel ? N = 1$	—	—	—	—	—	REL	2B	rr	3
BMS <i>rel</i>	Branch if Interrupt Mask Set	$PC \leftarrow (PC) + 2 + rel ? I = 1$	—	—	—	—	—	REL	2D	rr	3
BNE <i>rel</i>	Branch if Not Equal	$PC \leftarrow (PC) + 2 + rel ? Z = 0$	—	—	—	—	—	REL	26	rr	3
BPL <i>rel</i>	Branch if Plus	$PC \leftarrow (PC) + 2 + rel ? N = 0$	—	—	—	—	—	REL	2A	rr	3
BRA <i>rel</i>	Branch Always	$PC \leftarrow (PC) + 2 + rel ? 1 = 1$	—	—	—	—	—	REL	20	rr	3
BRCLR <i>n opr rel</i>	Branch if Bit n Clear	$PC \leftarrow (PC) + 2 + rel ? Mn = 0$	—	—	—	—	↕	DIR (b0) DIR (b1) DIR (b2) DIR (b3) DIR (b4) DIR (b5) DIR (b6) DIR (b7)	01 03 05 07 09 0B 0D 0F	dd rr dd rr dd rr dd rr dd rr dd rr dd rr dd rr	5 5 5 5 5 5 5 5
BRN <i>rel</i>	Branch Never	$PC \leftarrow (PC) + 2 + rel ? 1 = 0$	—	—	—	—	—	REL	21	rr	3
BRSET <i>n opr rel</i>	Branch if Bit n Set	$PC \leftarrow (PC) + 2 + rel ? Mn = 1$	—	—	—	—	↕	DIR (b0) DIR (b1) DIR (b2) DIR (b3) DIR (b4) DIR (b5) DIR (b6) DIR (b7)	00 02 04 06 08 0A 0C 0E	dd rr dd rr dd rr dd rr dd rr dd rr dd rr dd rr	5 5 5 5 5 5 5 5
BSET <i>n opr</i>	Set Bit n	$Mn \leftarrow 1$	—	—	—	—	—	DIR (b0) DIR (b1) DIR (b2) DIR (b3) DIR (b4) DIR (b5) DIR (b6) DIR (b7)	10 12 14 16 18 1A 1C 1E	dd dd dd dd dd dd dd dd	5 5 5 5 5 5 5 5
BSR <i>rel</i>	Branch to Subroutine	$PC \leftarrow (PC) + 2$ ; push (PCL) $SP \leftarrow (SP) - 1$ ; push (PCH) $SP \leftarrow (SP) - 1$ $PC \leftarrow (PC) + rel$	—	—	—	—	—	REL	AD	rr	6
CLC	Clear Carry Bit	$C \leftarrow 0$	—	—	—	—	0	INH	98		2
CLI	Clear Interrupt Mask	$I \leftarrow 0$	—	0	—	—	—	INH	9A		2

## Table 3-6. Instruction Set Summary (Continued)

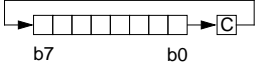
Source Form	Operation	Description	Effect on CCR					Address Mode	Opcode	Operand	Cycles
			H	I	N	Z	C				
CLR <i>opr</i> CLRA CLR X CLR <i>opr</i> ,X CLR ,X	Clear Byte	M ← \$00 A ← \$00 X ← \$00 M ← \$00 M ← \$00	—	—	0	1	—	DIR INH INH IX1 IX	3F 4F 5F 6F 7F	dd ff	5 3 3 6 5
CMP # <i>opr</i> CMP <i>opr</i> CMP <i>opr</i> CMP <i>opr</i> ,X CMP <i>opr</i> ,X CMP ,X	Compare Accumulator with Memory Byte	(A) – (M)	—	—	↕	↕	↕	IMM DIR EXT IX2 IX1 IX	A1 B1 C1 D1 E1 F1	ii dd hh ll ee ff ff	2 3 4 5 4 3
COM <i>opr</i> COMA COM X COM <i>opr</i> ,X COM ,X	Complement Byte (One's Complement)	M ← ( $\bar{M}$ ) = \$FF – (M) A ← ( $\bar{A}$ ) = \$FF – (A) X ← ( $\bar{X}$ ) = \$FF – (X) M ← ( $\bar{M}$ ) = \$FF – (M) M ← ( $\bar{M}$ ) = \$FF – (M)	—	—	↕	↕	1	DIR INH INH IX1 IX	33 43 53 63 73	dd ff	5 3 3 6 5
CPX # <i>opr</i> CPX <i>opr</i> CPX <i>opr</i> CPX <i>opr</i> ,X CPX <i>opr</i> ,X CPX ,X	Compare Index Register with Memory Byte	(X) – (M)	—	—	↕	↕	↕	IMM DIR EXT IX2 IX1 IX	A3 B3 C3 D3 E3 F3	ii dd hh ll ee ff ff	2 3 4 5 4 3
DEC <i>opr</i> DECA DEC X DEC <i>opr</i> ,X DEC ,X	Decrement Byte	M ← (M) – 1 A ← (A) – 1 X ← (X) – 1 M ← (M) – 1 M ← (M) – 1	—	—	↕	↕	—	DIR INH INH IX1 IX	3A 4A 5A 6A 7A	dd ff	5 3 3 6 5
EOR # <i>opr</i> EOR <i>opr</i> EOR <i>opr</i> EOR <i>opr</i> ,X EOR <i>opr</i> ,X EOR ,X	EXCLUSIVE OR Accumulator with Memory Byte	A ← (A) ⊕ (M)	—	—	↕	↕	—	IMM DIR EXT IX2 IX1 IX	A8 B8 C8 D8 E8 F8	ii dd hh ll ee ff ff	2 3 4 5 4 3
INC <i>opr</i> INCA INC X INC <i>opr</i> ,X INC ,X	Increment Byte	M ← (M) + 1 A ← (A) + 1 X ← (X) + 1 M ← (M) + 1 M ← (M) + 1	—	—	↕	↕	—	DIR INH INH IX1 IX	3C 4C 5C 6C 7C	dd ff	5 3 3 6 5
JMP <i>opr</i> JMP <i>opr</i> JMP <i>opr</i> ,X JMP <i>opr</i> ,X JMP ,X	Unconditional Jump	PC ← Jump Address	—	—	—	—	—	DIR EXT IX2 IX1 IX	BC CC DC EC FC	dd hh ll ee ff ff	2 3 4 3 2



**Table 3-6. Instruction Set Summary (Continued)**

Source Form	Operation	Description	Effect on CCR					Address Mode	Opcode	Operand	Cycles
			H	I	N	Z	C				
JSR <i>opr</i> JSR <i>opr</i> JSR <i>opr,X</i> JSR <i>opr,X</i> JSR ,X	Jump to Subroutine	PC ← (PC) + n (n = 1, 2, or 3) Push (PCL); SP ← (SP) - 1 Push (PCH); SP ← (SP) - 1 PC ← Effective Address	—	—	—	—	—	DIR EXT IX2 IX1 IX	BD CD DD ED FD	dd hh ll ee ff ff	5 6 7 6 5
LDA # <i>opr</i> LDA <i>opr</i> LDA <i>opr</i> LDA <i>opr,X</i> LDA <i>opr,X</i> LDA ,X	Load Accumulator with Memory Byte	A ← (M)	—	—	↕	↕	—	IMM DIR EXT IX2 IX1 IX	A6 B6 C6 D6 E6 F6	ii dd hh ll ee ff ff	2 3 4 5 4 3
LDX # <i>opr</i> LDX <i>opr</i> LDX <i>opr</i> LDX <i>opr,X</i> LDX <i>opr,X</i> LDX ,X	Load Index Register with Memory Byte	X ← (M)	—	—	↕	↕	—	IMM DIR EXT IX2 IX1 IX	AE BE CE DE EE FE	ii dd hh ll ee ff ff	2 3 4 5 4 3
LSL <i>opr</i> LSLA LSLX LSL <i>opr,X</i> LSL ,X	Logical Shift Left (Same as ASL)		—	—	↕	↕	↕	DIR INH INH IX1 IX	38 48 58 68 78	dd ff	5 3 3 6 5
LSR <i>opr</i> LSRA LSRX LSR <i>opr,X</i> LSR ,X	Logical Shift Right		—	—	0	↕	↕	DIR INH INH IX1 IX	34 44 54 64 74	dd ff	5 3 3 6 5
MUL	Unsigned Multiply	X : A ← (X) × (A)	0	—	—	—	0	INH	42		11
NEG <i>opr</i> NEGA NEGX NEG <i>opr,X</i> NEG ,X	Negate Byte (Two's Complement)	M ← -(M) = \$00 - (M) A ← -(A) = \$00 - (A) X ← -(X) = \$00 - (X) M ← -(M) = \$00 - (M) M ← -(M) = \$00 - (M)	—	—	↕	↕	↕	DIR INH INH IX1 IX	30 40 50 60 70	dd ff	5 3 3 6 5
NOP	No Operation		—	—	—	—	—	INH	9D		2
ORA # <i>opr</i> ORA <i>opr</i> ORA <i>opr</i> ORA <i>opr,X</i> ORA <i>opr,X</i> ORA ,X	Logical OR Accumulator with Memory	A ← (A) ∨ (M)	—	—	↕	↕	—	IMM DIR EXT IX2 IX1 IX	AA BA CA DA EA FA	ii dd hh ll ee ff ff	2 3 4 5 4 3
ROL <i>opr</i> ROLA ROLX ROL <i>opr,X</i> ROL ,X	Rotate Byte Left through Carry Bit		—	—	↕	↕	↕	DIR INH INH IX1 IX	39 49 59 69 79	dd ff	5 3 3 6 5

## Table 3-6. Instruction Set Summary (Continued)

Source Form	Operation	Description	Effect on CCR					Address Mode	Opcode	Operand	Cycles
			H	I	N	Z	C				
ROR <i>opr</i> RORA RORX ROR <i>opr,X</i> ROR ,X	Rotate Byte Right through Carry Bit		—	—	↕	↕	↕	DIR INH INH IX1 IX	36 46 56 66 76	dd  ff	5 3 3 6 5
RSP	Reset Stack Pointer	SP ← \$00FF	—	—	—	—	—	INH	9C		2
RTI	Return from Interrupt	SP ← (SP) + 1; Pull (CCR) SP ← (SP) + 1; Pull (A) SP ← (SP) + 1; Pull (X) SP ← (SP) + 1; Pull (PCH) SP ← (SP) + 1; Pull (PCL)	↕	↕	↕	↕	↕	INH	80		9
RTS	Return from Subroutine	SP ← (SP) + 1; Pull (PCH) SP ← (SP) + 1; Pull (PCL)	—	—	—	—	—	INH	81		6
SBC # <i>opr</i> SBC <i>opr</i> SBC <i>opr</i> SBC <i>opr,X</i> SBC <i>opr,X</i> SBC ,X	Subtract Memory Byte and Carry Bit from Accumulator	A ← (A) – (M) – (C)	—	—	↕	↕	↕	IMM DIR EXT IX2 IX1 IX	A2 B2 C2 D2 E2 F2	ii dd hh ll ee ff ff	2 3 4 5 4 3
SEC	Set Carry Bit	C ← 1	—	—	—	—	1	INH	99		2
SEI	Set Interrupt Mask	I ← 1	—	1	—	—	—	INH	9B		2
STA <i>opr</i> STA <i>opr</i> STA <i>opr,X</i> STA <i>opr,X</i> STA ,X	Store Accumulator in Memory	M ← (A)	—	—	↕	↕	—	DIR EXT IX2 IX1 IX	B7 C7 D7 E7 F7	dd hh ll ee ff ff	4 5 6 5 4
STX <i>opr</i> STX <i>opr</i> STX <i>opr,X</i> STX <i>opr,X</i> STX ,X	Store Index Register In Memory	M ← (X)	—	—	↕	↕	—	DIR EXT IX2 IX1 IX	BF CF DF EF FF	dd hh ll ee ff ff	4 5 6 5 4
SUB # <i>opr</i> SUB <i>opr</i> SUB <i>opr</i> SUB <i>opr,X</i> SUB <i>opr,X</i> SUB ,X	Subtract Memory Byte from Accumulator	A ← (A) – (M)	—	—	↕	↕	↕	IMM DIR EXT IX2 IX1 IX	A0 B0 C0 D0 E0 F0	ii dd hh ll ee ff ff	2 3 4 5 4 3
SWI	Software Interrupt	PC ← (PC) + 1; Push (PCL) SP ← (SP) – 1; Push (PCH) SP ← (SP) – 1; Push (X) SP ← (SP) – 1; Push (A) SP ← (SP) – 1; Push (CCR) SP ← (SP) – 1; I ← 1 PCH ← Interrupt Vector High Byte PCL ← Interrupt Vector Low Byte	—	1	—	—	—	INH	83		10
TAX	Transfer Accumulator to Index Register	X ← (A)	—	—	—	—	—	INH	97		2

**Table 3-6. Instruction Set Summary (Continued)**

Source Form	Operation	Description	Effect on CCR					Address Mode	Opcode	Operand	Cycles
			H	I	N	Z	C				
TST <i>opr</i> TSTA TSTX TST <i>opr,X</i> TST <i>,X</i>	Test Memory Byte for Negative or Zero	(M) – \$00	—	—	↕	↕	—	DIR INH INH IX1 IX	3D 4D 5D 6D 7D	dd  ff	4 3 3 5 4
TXA	Transfer Index Register to Accumulator	A ← (X)	—	—	—	—	—	INH	9F		2
WAIT	Stop CPU Clock and Enable Interrupts		—	0 ◇	—	—	—	INH	8F		2

- |          |   |            |                                      |
|----------|---|------------|--------------------------------------|
| A        | Accumulator   | <i>opr</i> | Operand (one or two bytes)           |
| C        | Carry/borrow flag   | PC         | Program counter                      |
| CCR      | Condition code register   | PCH        | Program counter high byte            |
| dd       | Direct address of operand   | PCL        | Program counter low byte             |
| dd rr    | Direct address of operand and relative offset of branch instruction | REL        | Relative addressing mode             |
| DIR      | Direct addressing mode  | <i>rel</i> | Relative program counter offset byte |
| ee ff    | High and low bytes of offset in indexed, 16-bit offset addressing   | rr         | Relative program counter offset byte |
| EXT      | Extended addressing mode  | SP         | Stack pointer                        |
| ff       | Offset byte in indexed, 8-bit offset addressing                     | X          | Index register                       |
| H        | Half-carry flag   | Z          | Zero flag                            |
| hh ll    | High and low bytes of operand address in extended addressing        | #          | Immediate value                      |
| I        | Interrupt mask  | ^          | Logical AND                          |
| ii       | Immediate operand byte  | ∨          | Logical OR                           |
| IMM      | Immediate addressing mode   | ⊕          | Logical EXCLUSIVE OR                 |
| INH      | Inherent addressing mode  | ( )        | Contents of                          |
| IX       | Indexed, no offset addressing mode                                  | -( )       | Negation (two's complement)          |
| IX1      | Indexed, 8-bit offset addressing mode                               | ←          | Loaded with                          |
| IX2      | Indexed, 16-bit offset addressing mode                              | ?          | If                                   |
| M        | Memory location   | :          | Concatenated with                    |
| N        | Negative flag   | ↕          | Set or cleared                       |
| <i>n</i> | Any bit   | —          | Not affected                         |

Table 3-7. Opcode Map

MSB LSB	Bit Manipulation		Branch		Read-Modify-Write				Control			Register/Memory								
	DIR	DIR	REL	REL	DIR	INH	INH	INH	IX1	IX	INH	INH	IMM	DIR	EXT	IX2	IX1	IX	MSB LSB	
0	5 3	5 3	5 3	5 3	5 3	5 3	5 3	5 3	5 3	5 3	5 3	5 3	5 3	5 3	5 3	5 3	5 3	5 3	5 3	0
1	5 3	5 3	5 3	5 3	5 3	5 3	5 3	5 3	5 3	5 3	5 3	5 3	5 3	5 3	5 3	5 3	5 3	5 3	5 3	1
2	5 3	5 3	5 3	5 3	5 3	5 3	5 3	5 3	5 3	5 3	5 3	5 3	5 3	5 3	5 3	5 3	5 3	5 3	5 3	2
3	5 3	5 3	5 3	5 3	5 3	5 3	5 3	5 3	5 3	5 3	5 3	5 3	5 3	5 3	5 3	5 3	5 3	5 3	5 3	3
4	5 3	5 3	5 3	5 3	5 3	5 3	5 3	5 3	5 3	5 3	5 3	5 3	5 3	5 3	5 3	5 3	5 3	5 3	5 3	4
5	5 3	5 3	5 3	5 3	5 3	5 3	5 3	5 3	5 3	5 3	5 3	5 3	5 3	5 3	5 3	5 3	5 3	5 3	5 3	5
6	5 3	5 3	5 3	5 3	5 3	5 3	5 3	5 3	5 3	5 3	5 3	5 3	5 3	5 3	5 3	5 3	5 3	5 3	5 3	6
7	5 3	5 3	5 3	5 3	5 3	5 3	5 3	5 3	5 3	5 3	5 3	5 3	5 3	5 3	5 3	5 3	5 3	5 3	5 3	7
8	5 3	5 3	5 3	5 3	5 3	5 3	5 3	5 3	5 3	5 3	5 3	5 3	5 3	5 3	5 3	5 3	5 3	5 3	5 3	8
9	5 3	5 3	5 3	5 3	5 3	5 3	5 3	5 3	5 3	5 3	5 3	5 3	5 3	5 3	5 3	5 3	5 3	5 3	5 3	9
A	5 3	5 3	5 3	5 3	5 3	5 3	5 3	5 3	5 3	5 3	5 3	5 3	5 3	5 3	5 3	5 3	5 3	5 3	5 3	A
B	5 3	5 3	5 3	5 3	5 3	5 3	5 3	5 3	5 3	5 3	5 3	5 3	5 3	5 3	5 3	5 3	5 3	5 3	5 3	B
C	5 3	5 3	5 3	5 3	5 3	5 3	5 3	5 3	5 3	5 3	5 3	5 3	5 3	5 3	5 3	5 3	5 3	5 3	5 3	C
D	5 3	5 3	5 3	5 3	5 3	5 3	5 3	5 3	5 3	5 3	5 3	5 3	5 3	5 3	5 3	5 3	5 3	5 3	5 3	D
E	5 3	5 3	5 3	5 3	5 3	5 3	5 3	5 3	5 3	5 3	5 3	5 3	5 3	5 3	5 3	5 3	5 3	5 3	5 3	E
F	5 3	5 3	5 3	5 3	5 3	5 3	5 3	5 3	5 3	5 3	5 3	5 3	5 3	5 3	5 3	5 3	5 3	5 3	5 3	F

INH = Inherent  
 REL = Relative  
 IMM = Immediate  
 IX = Indexed, No Offset  
 DIR = Direct  
 X1 = Indexed, 8-Bit Offset  
 EXT = Extended  
 IX2 = Indexed, 16-Bit Offset

## Section 4. Interrupts

### 4.1 Contents

4.2	Introduction . . . . .	60
4.3	CPU Interrupt Processing . . . . .	60
4.4	Reset Interrupt Sequence . . . . .	63
4.5	Software Interrupt (SWI) . . . . .	63
4.6	Hardware Interrupts . . . . .	63
4.7	External Interrupt (IRQ/Keyboard) . . . . .	63
4.8	8-Bit Timer Interrupt . . . . .	64
4.9	16-Bit Timer1 Interrupt . . . . .	64
4.10	16-Bit Timer2 Interrupt . . . . .	64
4.11	SCI Interrupt . . . . .	65
4.12	SPI Interrupt . . . . .	65
4.13	WAIT Mode . . . . .	65

## 4.2 Introduction

The MCU can be interrupted eight different ways:

1. Nonmaskable Software Interrupt Instruction (SWI)
2. External Asynchronous Interrupt (IRQ)
3. External Keyboard Wakeup on Port A
4. Internal 8 bit Timer Interrupt (CTIMER)
5. Internal 16-bit Timer1 Interrupt (TIMER1)
6. Internal 16-bit Timer2 Interrupt (TIMER2)
7. Internal Serial Communications Interface Interrupt (SCI)
8. Internal Serial Peripheral Interface Interrupt (SPI)

## 4.3 CPU Interrupt Processing

Interrupts cause the processor to save register contents on the stack and to set the interrupt mask (I-bit) to prevent additional interrupts. Unlike RESET, hardware interrupts do not cause the current instruction execution to be halted, but are considered pending until the current instruction is complete.

If interrupts are not masked (I-bit in the CCR is clear) and the corresponding interrupt enable bit is set, then the processor will proceed with interrupt processing. Otherwise, the next instruction is fetched and executed. If an interrupt occurs the processor completes the current instruction, then stacks the current CPU register states, sets the I-bit to inhibit further interrupts, and finally checks the pending hardware interrupts. If more than one interrupt is pending following the stacking operation, the interrupt with the highest vector location shown in **Table 4-1** will be serviced first. The SWI is executed the same as any other instruction, regardless of the I-bit state.

When an interrupt is to be processed the CPU fetches the address of the appropriate interrupt software service routine from the vector table at locations \$3FF0 to \$3FFF as defined in **Table 4-1**.

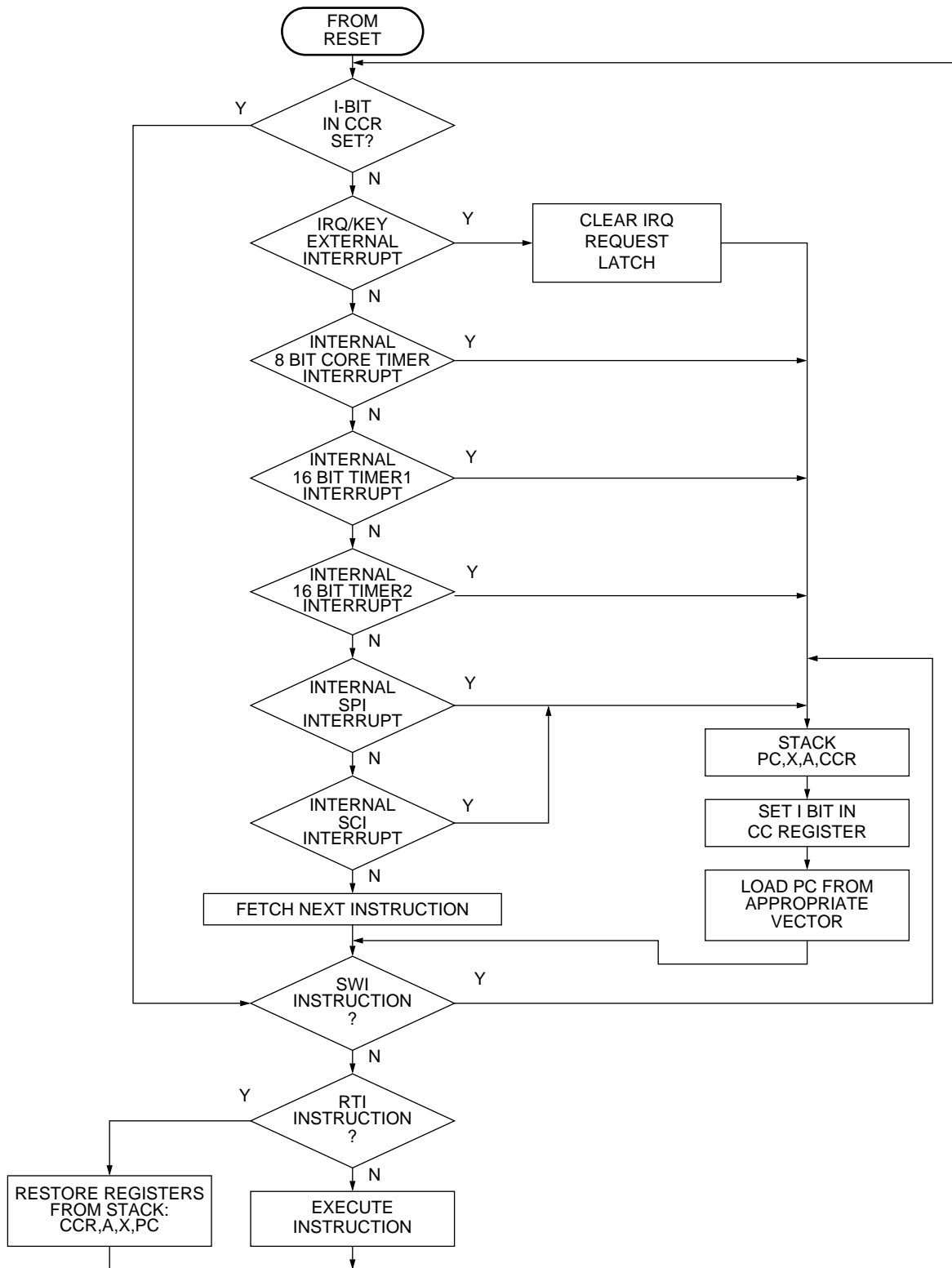
**Table 4-1. Reset/Interrupt Vector Addresses**

Function	Source	Local Mask	Global Mask	Priority (1 = Highest)	Vector Address
Reset	Power-On Logic	None	None	1	\$3FFE–\$3FFF
	RESET Pin				
	COP Watchdog				
Software Interrupt (SWI)	User Code	None	None	Same Priority As Instruction	\$3FFC–\$3FFD
External Interrupt / KEY wakeup	$\overline{\text{IRQ}}$ Pin	None	I Bit	2	\$3FFA–\$3FFB
	PTA KEY Pins	PAIE Bits			
Core Timer Interrupts	RTIF Bit	RTIE Bit	I Bit	3	\$3FF8–\$3FF9
	TOF Bit	TOFE Bit			
16-Bit Timer 1 Interrupts	ICF Bits	ICIE Bits	I Bit	4	\$3FF6–\$3FF7
	OCF Bits	OCIE Bits			
	TOF Bit	TOIE Bit			
16-Bit Timer 2 Interrupts	ICF Bits	ICIE Bits	I Bit	5	\$3FF4–\$3FF5
	OCF Bits	OCIE Bits			
	TOF Bit	TOIE Bit			
SPI Interrupts	SPIF Bit	SPIE	I Bit	6	\$3FF2–\$3FF3
	MODF Bit				
SCI Interrupts	TDRE Bit	TCIE Bit	I Bit	7	\$3FF0–\$3FF1
	TC Bit				
	RDRF Bit	RIE Bit			
	OR Bit				
	IDLE Bit				

The M68HC05 CPU does not support interruptible instructions, therefore, the maximum latency to the first instruction of the interrupt service routine must include the longest instruction execution time plus stacking overhead.

$$\text{Latency} = (\text{Longest instruction execution time} + 10) \times t_{\text{CYC}} \text{ secs}$$

An RTI instruction is used to signify when the interrupt software service routine is completed. The RTI instruction causes the register contents to be recovered from the stack and normal processing to resume at the next instruction that was to be executed when the interrupt took place. **Figure 4-1** shows the sequence of events that occur during interrupt processing.



**Figure 4-1. Interrupt Processing Flowchart**



## 4.4 Reset Interrupt Sequence

The reset function is not in the strictest sense an interrupt; however, it is acted upon in a similar manner as shown in **Figure 4-1**. A low level input on the  $\overline{\text{RESET}}$  pin or internally generated RST signal causes the program to vector to its starting address which is specified by the contents of memory locations \$3FFE and \$3FFF. The I-bit in the condition code register is also set. The MCU is configured to a known state during this type of reset as described in **Section 5 Resets**.

## 4.5 Software Interrupt (SWI)

The SWI is an executable instruction and a non-maskable interrupt since it is executed regardless of the state of the I-bit in the CCR. If the I-bit is zero (interrupts enabled), the SWI instruction executes after interrupts which were pending before the SWI was fetched, or before interrupts generated after the SWI was fetched. The interrupt service routine address is specified by the contents of memory locations \$3FFC and \$3FFD.

## 4.6 Hardware Interrupts

All hardware interrupts except reset are maskable by the I-bit in the CCR. If the I-bit is set, all hardware interrupts (internal and external) are disabled. Clearing the I-bit enables the hardware interrupts. There are two types of hardware interrupts (external, internal) which are explained in the following sections.

## 4.7 External Interrupt (IRQ/Keyboard)

If the interrupt mask bit (I bit) of the CCR is set, all maskable interrupts (internal and external) are disabled. Clearing the I bit enables interrupts. The interrupt request is latched immediately following the falling edge of IRQ. It is then synchronized internally and serviced by the interrupt service routine located at the address specified by the contents of \$3FFA and \$3FFB.

Either a level-sensitive and edge-sensitive trigger, or an edge-sensitive-only trigger can be implemented by software.

**NOTE:** *The internal interrupt latch is cleared in the first part of the interrupt service routine; therefore, one external interrupt pulse could be latched and serviced as soon as the I bit is cleared.*

*The BIH and BIL instructions will only apply to the level on the  $\overline{IRQ}$  pin itself, and not to the output of the logic OR function with the Port A keyboard wakeup interrupts. The state of the individual Port A pins can be checked by reading the appropriate Port A pins as inputs.*

## 4.8 8-Bit Timer Interrupt

This timer can create two types of interrupts. A timer overflow interrupt will occur whenever the 8-bit timer rolls over from \$FF to \$00 and the enable bit TOFE is set. A real time interrupt will occur whenever the programmed time elapses and the enable bit RTIE is set. This interrupt will vector to the interrupt service routine located at the address specified by the contents of memory location \$3FF8 and \$3FF9.

## 4.9 16-Bit Timer1 Interrupt

There are five different timer interrupt flags that cause a 16-bit timer1 interrupt whenever they are set and enabled. The interrupt flags are in the timer1 status register (TSR), and the enable bits are in the timer1 control register1 (TCR1). Any of these interrupts will vector to the same interrupt service routine, located at the address specified by the contents of memory location \$3FF6 and \$3FF7.

## 4.10 16-Bit Timer2 Interrupt

There are five different timer interrupt flags that cause a 16-bit timer2 interrupt whenever they are set and enabled. The interrupt flags are in the timer2 status register (TSR), and the enable bits are in the timer2 control register1 (TCR1). Any of these interrupts will vector to the same

interrupt service routine, located at the address specified by the contents of memory location \$3FF4 and \$3FF5.

## 4.11 SCI Interrupt

There are five different interrupt flags (TDRE, TC, OR, RDRF, IDLE) that will cause an SCI interrupt whenever they are set and enabled. These five interrupt flags are found in the five most significant bits of the SCI status register SCSR. The actual processor interrupt is generated only if the I-bit in the condition code register is clear and the enable bit in the serial communications control register 2 (SCCR2) is enabled. The SCI interrupt causes the program counter to vector to the address pointed to by memory locations \$3FF2–\$3FF3 which contain the start address of the interrupt service routine. Software in the SCI interrupt service routine must determine the priority and cause of the SCI interrupt by examining the interrupt flags and the status bits in the serial communications status register (SCSR).

## 4.12 SPI Interrupt

There are two different SPI interrupt flags that cause an SPI interrupt whenever they are set and enabled. The interrupt flags are in the SPI status register (SPSR), and the enable bits are in the SPI control register (SPCR). Either of these interrupts will vector to the same interrupt service routine, located at the address specified by the contents of memory locations \$3FF0 and \$3FF1.

## 4.13 WAIT Mode

All modules that are capable of generating interrupts in WAIT mode will be allowed to do so if the module is configured properly. The I-bit is automatically cleared when WAIT mode is entered. Interrupts detected on port A are recognized in WAIT modes.



## Section 5. Resets

### 5.1 Contents

5.2	Introduction . . . . .	67
5.3	External Reset (RESET) . . . . .	67
5.4	Internal Resets . . . . .	68
5.5	Power-On Reset (POR) . . . . .	70
5.6	Computer Operating Properly Reset (COPR) . . . . .	70
5.6.1	Resetting the COP . . . . .	70
5.6.2	COP During WAIT Mode . . . . .	71
5.6.3	COP Watchdog Timer Considerations . . . . .	71
5.6.4	COP Register . . . . .	72
5.7	Illegal Address Reset . . . . .	72
5.8	Low Voltage Reset (LVR) . . . . .	72
5.8.1	LVR Operation in WAIT . . . . .	73

### 5.2 Introduction

The MCU can be reset from five sources: one external input and four internal restart conditions. The  $\overline{\text{RESET}}$  pin is an input with a Schmitt trigger. All the internal peripheral modules will be reset by the internal reset signal (RST). Refer to **Figure 5-2** for reset timing detail. The  $\overline{\text{RESET}}$  pin contains an internal pullup device.

### 5.3 External Reset ( $\overline{\text{RESET}}$ )

The  $\overline{\text{RESET}}$  pin is the only external source of a reset. This pin is connected to a Schmitt trigger input gate to provide an upper and lower threshold voltage separated by a minimum amount of hysteresis. This external reset occurs whenever the  $\overline{\text{RESET}}$  pin is pulled below the lower

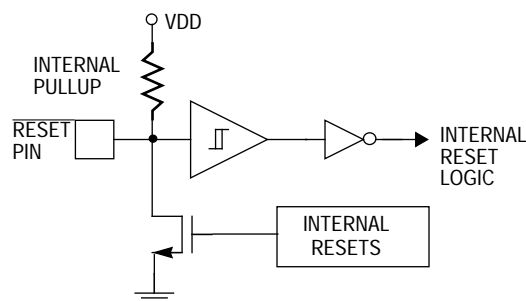
threshold and remains in reset until the  $\overline{\text{RESET}}$  pin rises above the upper threshold. This active low input will generate the RST signal and reset the CPU and peripherals. When the  $\overline{\text{RESET}}$  pin goes high, the MCU will resume operation on the following cycle.

**NOTE:** *Activation of the RST signal is generally referred to as reset of the device, unless otherwise specified.*

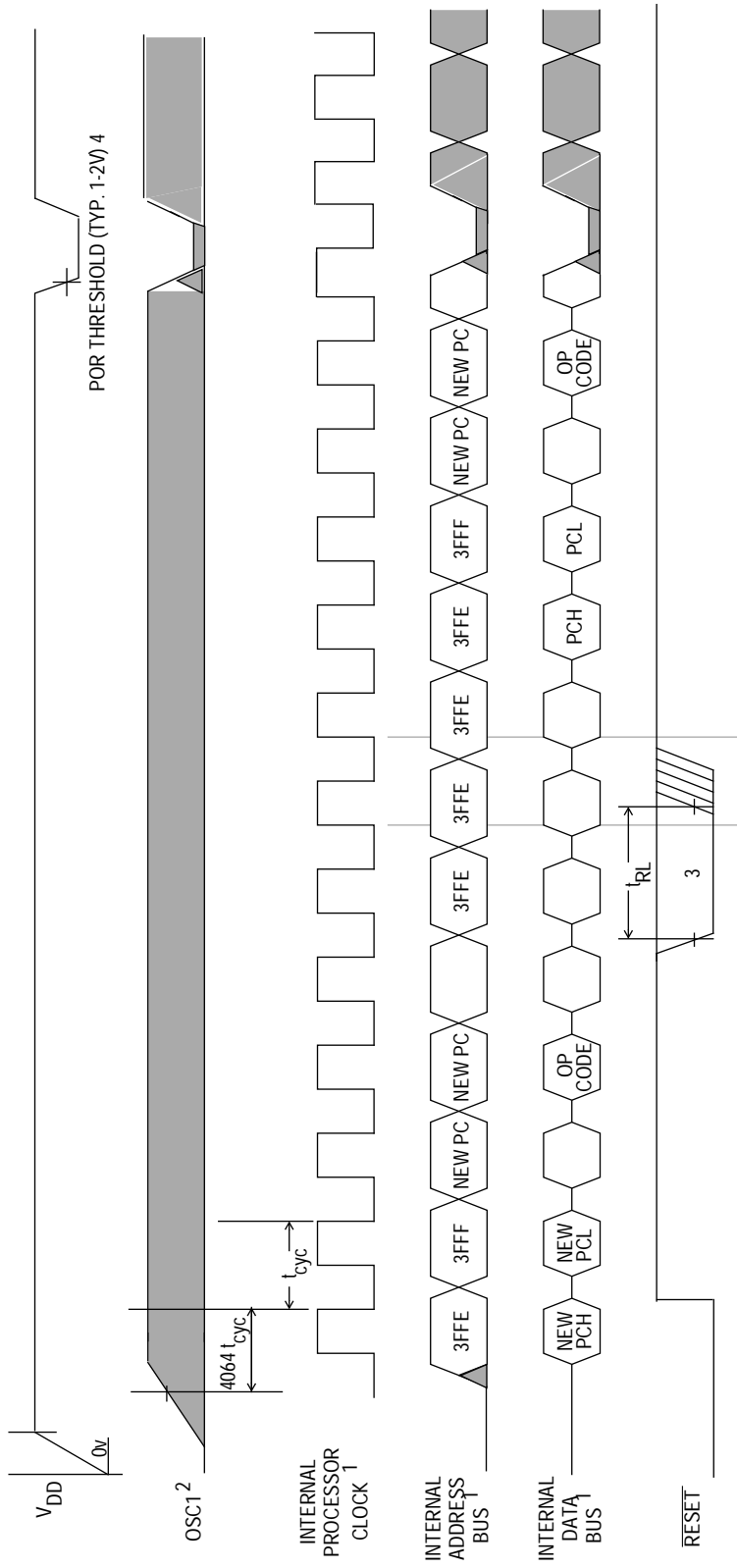
The  $\overline{\text{RESET}}$  pin can also act as an open drain output. It will be pulled to a low state by an internal pulldown that is activated by any reset source. This  $\overline{\text{RESET}}$  pulldown device will be asserted for 3–4 cycles of the internal clock,  $f_{\text{OP}}$ , or as long as an internal reset source is asserted. When the external  $\overline{\text{RESET}}$  pin is asserted, the pulldown device will be turned on for the 3–4 internal clock cycles.

## 5.4 Internal Resets

The four internally generated resets are the initial power-on reset function, the COP Watchdog Timer reset, the illegal address detector, and the low voltage reset. All internal resets will also assert (pull to logic zero) the external  $\overline{\text{RESET}}$  pin for the duration of the reset or 3–4 internal clock cycles, whichever is longer.



**Figure 5-1. Internal Resets**



NOTES:

1. Internal timing signal and bus information not available externally.
  2. OSC1 line is not meant to represent frequency. It is only used to represent time.
  3. The next rising edge of the internal processor clock following the rising edge of RESET initiates the reset sequence.
  4.  $V_{DD}$  must fall to a level lower than  $V_{POR}$  in order to be recognized as a power on reset.
- If LVR is enabled,  $V_{DD}$  must fall below the LVR Power Off Reset Voltage  $V_{ROFF}$ .

**Figure 5-2. RESET and POR Timing Diagram**

## 5.5 Power-On Reset (POR)

The internal POR is generated on power-up to allow the clock oscillator to stabilize. The POR is strictly for power turn-on conditions and is not able to detect a drop in the power supply voltage (brown-out). There is an oscillator stabilization delay of 4064 internal processor bus clock cycles after the oscillator becomes active.

The POR will generate the RST signal which will reset the CPU. If any other reset function is active at the end of this 4064 cycle delay, the RST signal will remain in the reset condition until the other reset condition(s) end.

POR will activate the  $\overline{\text{RESET}}$  pin pulldown device connected to the pin.  $V_{\text{DD}}$  must drop below  $V_{\text{POR}}$  in order for the internal POR circuit to detect the next rise of  $V_{\text{DD}}$ .

## 5.6 Computer Operating Properly Reset (COPR)

The MCU contains a watchdog timer that automatically times out if not reset (cleared) within a specific time by a program reset sequence. If the COP watchdog timer is allowed to time-out, an internal reset is generated to reset the MCU. Regardless of an internal or external reset, the MCU comes out of a COP reset according to the pin conditions that determine mode selection.

The COP reset function is enabled or disabled by the Mask option (COP) and is verified during production testing.

The COP Watchdog reset will activate the internal pulldown device connected to the  $\overline{\text{RESET}}$  pin.

### 5.6.1 Resetting the COP

Preventing a COP reset is done by writing a '0' to the COPR bit. This action will reset the counter and begin the time-out period again. The COPR bit is bit 0 of address \$3FF0. A read of address \$3FF0 will return user data programmed at that location.



### 5.6.2 COP During WAIT Mode

The COP will continue to operate normally during WAIT mode. The system should be configured to pull the device out of WAIT mode periodically and reset the COP by writing to the COPR bit to prevent a COP reset.

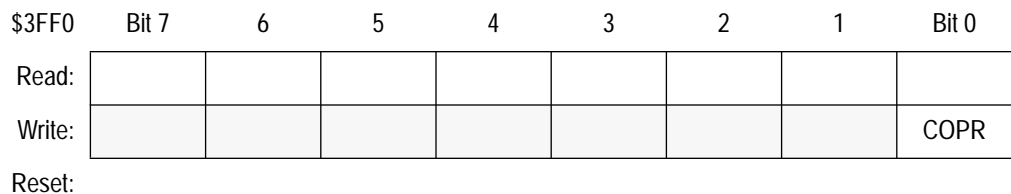
### 5.6.3 COP Watchdog Timer Considerations

The COP Watchdog Timer is active in User Mode if enabled by the Mask option (COP).

If the COP Watchdog Timer is selected, the COP will reset the MCU when it times out. Therefore, it is recommended that the COP Watchdog should be disabled for a system that must have intentional uses of the WAIT Mode for periods longer than the COP time-out period.

## 5.6.4 COP Register

The COP register is shared with the MSB of a user interrupt vector as shown in **Figure 5-3**. Reading this location will return whatever user data has been programmed at this location. Writing a '0' to the COPR bit in this location will clear the COP watchdog timer.



**Figure 5-3. COP Watchdog Timer Location Register (COPR)**

## 5.7 Illegal Address Reset

An illegal address reset is generated when the CPU attempts to fetch an instruction from either unimplemented address space (\$0150 to \$03FF, \$0500 to \$0FFF), Monitor ROM (\$3F00 to \$3FEF) or I/O address space (\$0000 to \$004F).

The illegal address reset will activate the internal pulldown device connected to the RESET pin.

**NOTE:** *No RTS, RTI or JMP,X instruction should be placed at the end of a memory block (RAM \$014F, EEPROM \$04FF, User ROM \$3EFF) since this results in an illegal address reset.*

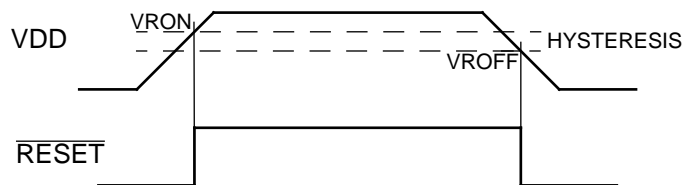
## 5.8 Low Voltage Reset (LVR)

The internal low voltage (LVR) reset is generated when  $V_{DD}$  falls below the LVR threshold  $V_{ROFF}$  and will be release following a POR delay starting when  $V_{DD}$  rises above  $V_{RON}$ . The LVR threshold is tested to be above the minimum operating voltage of the microcontroller and is intended to assure that the CPU will be held in reset when the  $V_{DD}$  supply voltage is below reasonable operating limits. A mask option is

provided to disable the LVR when the device is expected to normally operate at low voltages. Note that the  $V_{DD}$  rise and fall slew rates must be within the specification for proper LVR operation. If the specification is not met, the circuit will operate properly following a delay of  $V_{DD}/\text{Slew rate}$ .

The LVR will generate the RST signal which will reset the CPU and other peripherals. The low voltage reset will activate the internal pulldown device connected to the  $\overline{\text{RESET}}$  pin.

If any other reset function is active at the end of the LVR reset signal, the RST signal will remain in the reset condition until the other reset condition(s) end.



**Figure 5-4. Low Voltage Reset**

**NOTE:** An external capacity at the RST pin increases the reaction time for the generation of the internal reset and allows  $V_{DD}$  drops. Refer to **Figure 5-1**.

### 5.8.1 LVR Operation in WAIT

If enabled, the LVR supply voltage sense option is active during WAIT. Any reset source can bring the MCU out of WAIT mode.



## General Release Specification — MC68HC(7)05H12

---

# Section 6. Operating Modes

## 6.1 Contents

6.2	Introduction . . . . .	75
6.3	User Mode . . . . .	75
6.4	Monitor Mode . . . . .	76
6.5	Low Power Modes . . . . .	76
6.5.1	WAIT Mode . . . . .	77
6.5.2	Data Retention Mode . . . . .	78
6.5.3	Slow Mode . . . . .	78

## 6.2 Introduction

The normal operating mode of the MC68HC(7)05H12 is user (or single chip) mode. There is also a monitor (or bootloader) mode, primarily for programming and evaluation purpose. In addition to these modes, there are three low power modes which may be entered and exited at will from user mode: WAIT, Data Retention and Slow Mode. **Table 6-1** shows the conditions required to enter the modes of operation on the rising edge of  $\overline{\text{RESET}}$ , where  $V_{\text{TST}} = 2 \times V_{\text{DD}}$ .

**Table 6-1. Operating Mode Entry Conditions**

IRQ	PB0	Mode
$V_{\text{SS}}$ to $V_{\text{DD}}$	$V_{\text{SS}}$ to $V_{\text{DD}}$	User
$V_{\text{TST}}$	$V_{\text{DD}}$	Monitor

## 6.3 User Mode

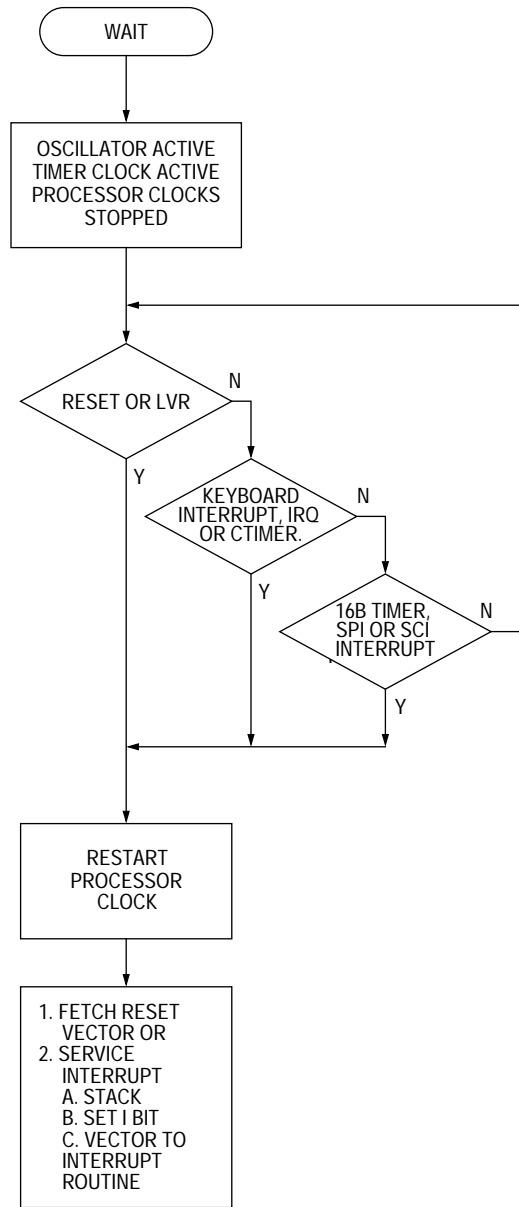
This is the intended mode of operation for executing user firmware. All user mode functions are explained in this specification.

### 6.4 Monitor Mode

This mode is used for programming the on-chip EPROM (705 version) and for the communication with a host computer via a standard RS-232 interface.

### 6.5 Low Power Modes

The MC68HC(7)05H12 is capable of running in one of several low-power operational modes. The WAIT instruction provides a mode that reduces the power required for the MCU by stopping various internal clocks. The flow of the WAIT mode is shown in **Figure 6-1**.



**Figure 6-1. WAIT Flowchart**

### 6.5.1 WAIT Mode

The WAIT instruction places the MCU in a low-power consumption mode. All CPU action is suspended, but the core timer, the 16 bit timers, the SPI/SCI, the ADC, and the PWM will or can remain active. An

interrupt, if enabled, from the core timer or any peripheral still active in WAIT mode will cause the MCU to exit WAIT mode.

During WAIT mode, the I bit in the CCR is cleared to enable interrupts. All other registers, memory, and input/output lines remain in their previous state. The core timer may be enabled to allow a periodic exit from the WAIT mode.

### 6.5.2 Data Retention Mode

The contents of RAM and CPU registers are retained at data retention supply voltage  $V_{DR}$ . This is called the data retention mode where the data is held, but the device is not guaranteed to operate. The  $\overline{\text{RESET}}$  pin must be held low during data-retention mode.

To put the MCU into data retention mode:

- Drive  $\overline{\text{RESET}}$  pin to zero.
- Lower the  $V_{DD}$  voltage. The  $\overline{\text{RESET}}$  pin must remain low continuously during data retention mode.

To take the MCU out of data retention mode:

- Return  $V_{DD}$  to normal operating level.
- Return the  $\overline{\text{RESET}}$  pin to logic one.

### 6.5.3 Slow Mode

The slow mode function is controlled by the system clock option (SC bit) in the system control register. It allows the user to interconnect under software control an extra divide-by-4 between the oscillator and the internal clock driver. This feature allows all the internal operations to slow down and thus reduces power consumption. It is particularly useful when entering Wait mode.

See **Section 2.3.1 System Control Register**.



## Section 7. Input/Output Ports

### 7.1 Contents

7.2	Introduction . . . . .	79
7.3	Port A . . . . .	80
7.3.1	Port A Keyboard Interrupt . . . . .	80
7.3.2	Port A Interrupt Edge Register . . . . .	81
7.3.3	Port A Interrupt Control Register . . . . .	81
7.3.4	Port A Interrupt Status Register . . . . .	82
7.4	Port B . . . . .	82
7.5	Port C . . . . .	83
7.6	Port D . . . . .	83
7.7	Port E and Port F (Power Drivers) . . . . .	83
7.7.1	Power Drivers for 360°Air Core Driven Instruments . . . . .	85
7.7.2	H-Bridge Driver . . . . .	86
7.7.3	Power Driver Circuit . . . . .	87
7.7.4	Short Circuit Detection . . . . .	88
7.7.5	Port E and Port F Mismatch Registers . . . . .	89
7.7.6	Driver States . . . . .	90
7.7.7	Port E and Port F Configurations . . . . .	92
7.7.8	H-Bridge Control with the PWM . . . . .	94
7.8	Port E and Port F During WAIT Mode . . . . .	95
7.9	Input/Output Programming . . . . .	95

### 7.2 Introduction

In single chip mode there is a total of 40 lines arranged as three 8-bit I/O ports (ports A, B and C), one 4-bit input only port (port D), 12 output only lines arranged as one 8-bit (port E) and one 4-bit (port F) port. The I/O

ports are programmable as either inputs or outputs under software control of the data direction registers.

**NOTE:** *To avoid a glitch on the output pins, write data to the I/O port data register before writing a one to the corresponding data direction register.*

### 7.3 Port A

Port A is an 8-bit bidirectional port. The port A Data register is at \$0000 and the port A data direction register (DDR) is at \$0004. Reset does not affect the data registers, but clears the data direction registers, thereby returning the ports to inputs. Writing a one to a DDR bit sets the corresponding port bit to output mode.

#### 7.3.1 Port A Keyboard Interrupt

The keyboard interrupt consists of 8 individual edge-sensitive interrupts with 8 interrupt flags. The keyboard interrupt is generated by a logical OR function of the 8 interrupt flags. The interrupt inputs are connected to PA0–7. All interrupts are maskable. If the interrupt mask bit (I bit) in the condition code register is set, all interrupts are disabled. Each interrupt can individually be masked by the corresponding PAIE7–0 bits in the port A interrupt control register. The trigger edges of the interrupt lines are programmable with the EDG7–0 bits in the port A interrupt edge register. The PA0–7 input lines have no internal pull-up resistors.

### 7.3.2 Port A Interrupt Edge Register

\$000D	Bit 7	6	5	4	3	2	1	Bit 0
Read:	EDGE7	EDGE6	EDGE5	EDGE4	EDGE3	EDGE2	EDGE1	EDGE0
Write:								
Reset:	0	0	0	0	0	0	0	0

**Figure 7-1. Port A Interrupt Edge Register (PAIED)**

#### EDGE7–0 — Port A Interrupt Edge

These bits select the corresponding trigger edges of the interrupt lines PA7–PA0. Note that changing these bits can cause an interrupt, if the corresponding pin is '1' and the bit changes from '0' to '1' or if the corresponding pin is '0' and the bit changes from '1' to '0'.

1 = Low to high edge sensitive

0 = High to low edge sensitive

### 7.3.3 Port A Interrupt Control Register

\$000E	Bit 7	6	5	4	3	2	1	Bit 0
Read:	PAIE7	PAIE6	PAIE5	PAIE4	PAIE3	PAIE2	PAIE1	PAIE0
Write:								
Reset:	0	0	0	0	0	0	0	0

**Figure 7-2. Port A Interrupt Control Register (PAICR)**

#### PAIE7–0 — Port A Interrupt Enable

Each of these bits enables the corresponding port A pin as interrupt line

1 = Corresponding port A interrupt enabled

0 = Corresponding port A interrupt disabled

## 7.3.4 Port A Interrupt Status Register

\$000F	Bit 7	6	5	4	3	2	1	Bit 0
Read:	PAIF7	PAIF6	PAIF5	PAIF4	PAIF3	PAIF2	PAIF1	PAIF0
Write:								
Reset:	0	0	0	0	0	0	0	0

**Figure 7-3. Port A Interrupt Status Register (PAISR)**

### PAIF7–0 — Port A Interrupt Flags

These flags indicate which of the port A interrupt requests is pending. The 8 interrupt flags can be reset individually if a '1' is written to the bit position.

- 1 = Flag set when corresponding transition is sensed (even if interrupt is disabled), writing '1' clears the flag
- 0 = No interrupt

## 7.4 Port B

Port B is an 8-bit bidirectional port. The port B data register is at \$0001, the port B data direction register (DDR) is at \$0005. Reset does not affect the data registers, but clears the data direction registers, thereby returning the ports to inputs. Writing a one to a DDR bit sets the corresponding port bit to output mode. The port pins PB5–PB7 are shared with the SPI system (MISO, MOSI, SCK). If the SPI system is enabled the pins PB5–PB7 are connected to the SPI system.

Pin PB2 is shared with the internal system clock ECLK. If the ECLK bit in the system option register is set the internal system clock is available through PB2 independently of the value of the port B data direction register. Refer to **Section 2.3.1 System Control Register** for more information. When the ECLK bit is set to '1' the port B data direction register can still be read or written, but does not impact the ECLK function at pin PB2. When the ECLK bit is set to '1' the port B data register bit 2 loses its contents and is not accessible.

## 7.5 Port C

Port C is an 8-bit bidirectional port. The port C data register is at \$0002, the port C data direction register (DDR) is at \$0006 and the port C control register is at \$0007. Reset does not affect the data registers, but clears the data direction registers, thereby returning the ports to inputs. Writing a one to a DDR bit sets the corresponding port bit to output mode. Reset clears the control register. The port pins PC0–PC5 are shared with the 16-bit timers (TCAP0–3, TCMP0–1). The lines PC0–PC3 must be set to input by resetting the DDR to enable correct input capture function. If the TCMP1 or TCMP2 bit in the control register is set the pins PC5, PC4 function as output compare lines from the Timer1 system otherwise they function as I/O lines. The port pins PC6, PC7 are shared with the SCI system (RDI, TDO). If the SCI is enabled the pins PC6, PC7 are connected to the SCI system.

## 7.6 Port D

Port D is an 4-bit input only port which shares all of its pins with the A/D converter (AN0 through AN3). The port D data register is located at address \$0003. When the A/D converter is active, one of these 4 input lines may be selected by the A/D multiplexer for conversion. A logical read of a selected input port will always return 0.

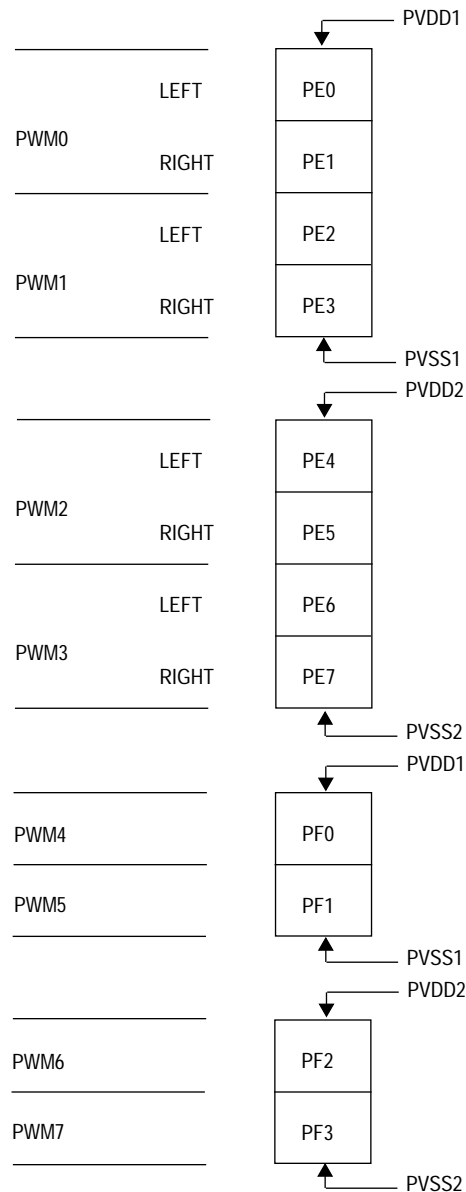
## 7.7 Port E and Port F (Power Drivers)

Port E is an 8-bit output only port. The port E data register is at \$0040. Reset clears the data register. The eight lines are shared with four PWM H-bridge driver pairs (left and right). The outputs are formed by power drivers. The port E PWM lines can support two 360° (large angle) aircore instruments.

Port F is a 4-bit output only port. The port F data register is at \$0042. Reset clears the data register. The four lines are shared with four PWM channels. The outputs are formed by power drivers. The port F PWM lines can support four 90° (small angle) aircore instruments.

The power drivers have a separate voltage supply.  $PV_{DD1}$  and  $PV_{SS1}$  is the supply for PE0–3 and PF0–1 and  $PV_{DD2}$  and  $PV_{SS2}$  is the supply for PE4–7 and PF2–3.

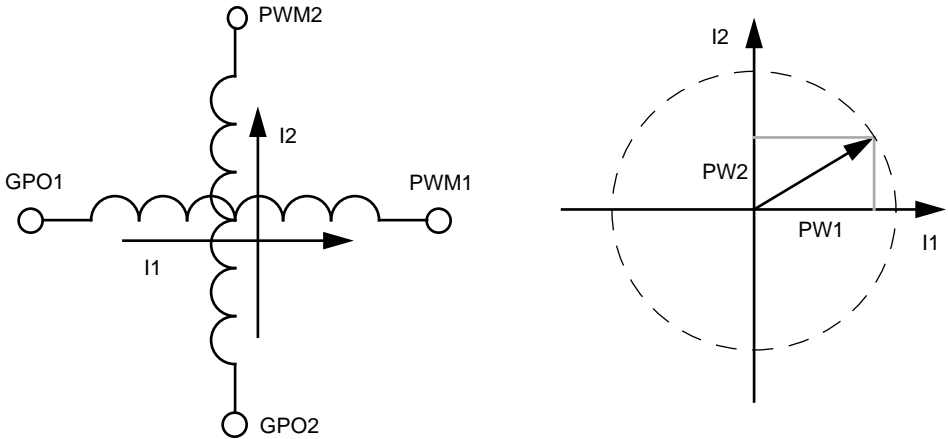
The power drivers contain short circuit detection and slew rate limitation for reduced RFI (EMC).



**Figure 7-4. Port E and Port F (Power Drivers)**

### 7.7.1 Power Drivers for 360° Air Core Driven Instruments

Two PWM H-bridge systems are used to drive a system with cross coupled coils for a dashboard instrument. A single bridge is controlled by one PWM channel in combination with a further general purpose output (GPO) channel. It is capable of driving one of the two coils of an aircore instrument. The pulse width ratio in one of the two PWM channels corresponds to the average value of the current through the coil.

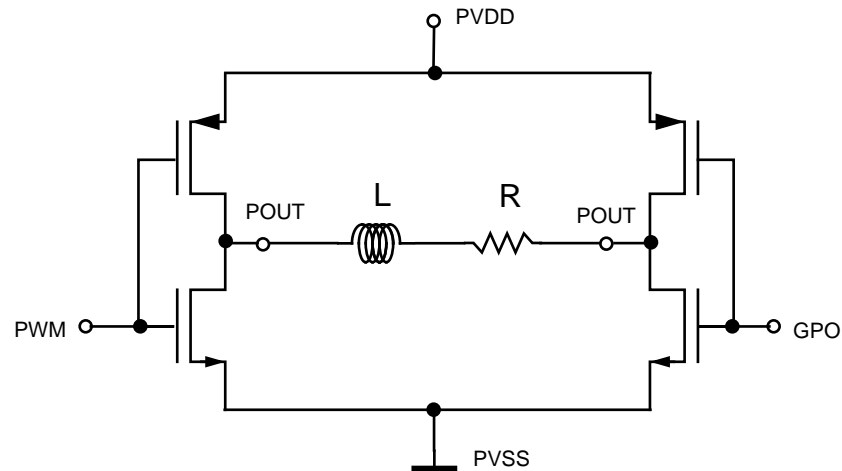


**Figure 7-5. Driving Cross Coupled Coils**

The vector ( $I_1, I_2$ ) of the currents through the coils in the cross coupled system is determined by the pulse widths (PW1, PW2). It also determines the elevation angle of the instrument.

## 7.7.2 H-Bridge Driver

Special power drivers in the H-bridge must be used to drive the system with coils, because high voltages at the driver outputs due to switching the coils would damage the circuits if the drivers are not protected against this.

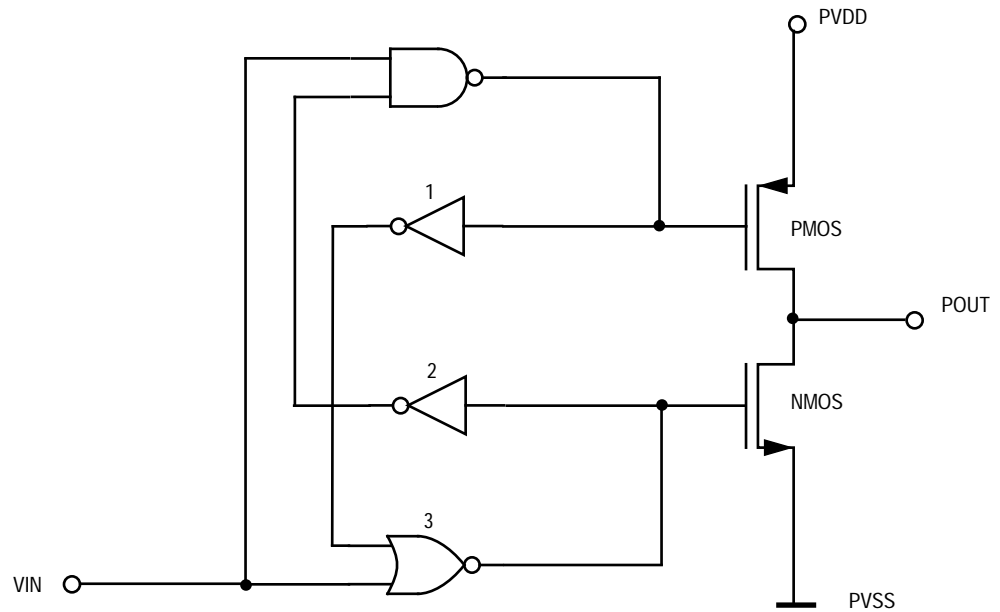


**Figure 7-6. H-Bridge Driver Circuit**

In order to avoid large switching currents through the N- and PMOS driver transistors both devices will not be active at the same time. On the other hand the switching delay between NMOS and PMOS transistor must be short, because the driver has to supply the coil circuit with a continuous current during the commutation. There would be diode currents into the bulk due to voltages below  $PV_{SS}$  or greater than  $PV_{DD}$  on the driver outputs if the commutation time is not short enough. Low voltage drops on the driver transistors are also necessary to avoid these diode currents.



### 7.7.3 Power Driver Circuit

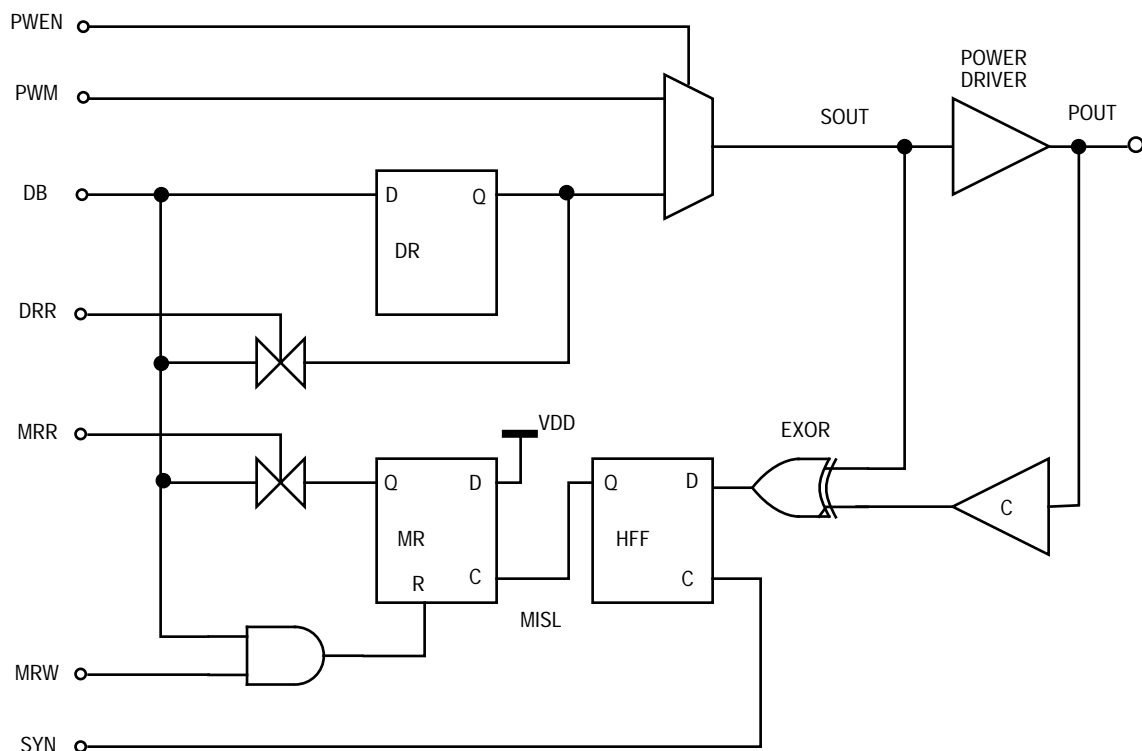


**Figure 7-7. Power Driver Circuit**

A high to low transition at the input VIN causes a low to high transition at the gate of the PMOS transistor. The NOR-gate 3 blocks the transition at VIN as long as the inverter 1 in the figure produces a low level. The result is that the PMOS and the NMOS devices are not active at the same time. An unsymmetrical sizing of the inverter 1 causes a fast propagation of the required low level to unblock the NOR-gate. This results in a short switching delay. The inverter 2 in the figure realizes a fast low to high transition at the output POUT.

## 7.7.4 Short Circuit Detection

The drivers contain a short circuit detection mechanism. The pin value of a single power driver output is compared with the set level of the actual power driver. A difference between both levels indicates a short circuit case at the actual power driver. The difference is stored as a logic '1' in the corresponding bit of the mismatch registers of port E or port F. They can be polled by software. In the short circuit case precautions like shutting down the failed power driver can be taken.



**Figure 7-8. Short Circuit Detection Circuitry**

**Figure 7-8** shows the circuitry for a single power driver port bit. Each output bit of ports E and F can either be controlled directly by the data register or it is linked to the PWM function. The PWEN signal which corresponds to the appropriate bit in the PWEN register determines the functionality which will appear on the output.

The actual output level POUT of a single power driver is compared with the set output level SOUT via the EXOR gate in the circuitry. The buffer C provides 'low' if the 'high' set output is significantly lower than PVDD or it provides a 'high' if the 'low' set output is significantly higher than PVSS. The comparison result is latched with the appropriate signal SYN which runs at bus frequency. The timing of the signal SYN depends on the amount of microshifts for the actual PWM channel. The SYN signal occurs 1/4 of a bus cycle later than the start of the PWM period. This ensures the PWM signal being stable on the output POUT. A mismatch between the levels SOUT and POUT which indicates a short circuit on the output results in a 'high' signal latched by the HFF. This latched mismatch signal MISL is now stored in the corresponding bit MR of the mismatch register. The mismatch register of port E or port F can be polled in a proper time period like an interrupt flag register. A read 'high' on the mismatch register bit has to be handled like an interrupt flag. It will be cleared by writing a logic '1' back to this register.

### 7.7.5 Port E and Port F Mismatch Registers

\$0041	Bit 7	6	5	4	3	2	1	Bit 0
Read:	bit 7	bit 6	bit 5	bit 4	bit 3	bit 2	bit 1	bit 0
Write:								
Reset:	0	0	0	0	0	0	0	0

**Figure 7-9. Port E Mismatch Register (PEMISM)**

Bit 7–0 — Port E short circuit indication

The bits 7–0 indicate a short circuit on the port E. Each bit is cleared by writing a '1' to it.

1 = Short circuit at the corresponding port E pin

0 = No short circuit at the corresponding port E pin

\$0043	Bit 7	6	5	4	3	2	1	Bit 0
Read:	0	0	0	0	bit 3	bit 2	bit 1	bit 0
Write:								
Reset:	0	0	0	0	0	0	0	0

**Figure 7-10. Port F Mismatch Register (PFMISM)**

Bit 3–0 — Port F short circuit indication

The bits 3–0 indicate a short circuit on the port F. Each bit is cleared by writing a ‘1’ to it.

1 = Short circuit at the corresponding port F pin

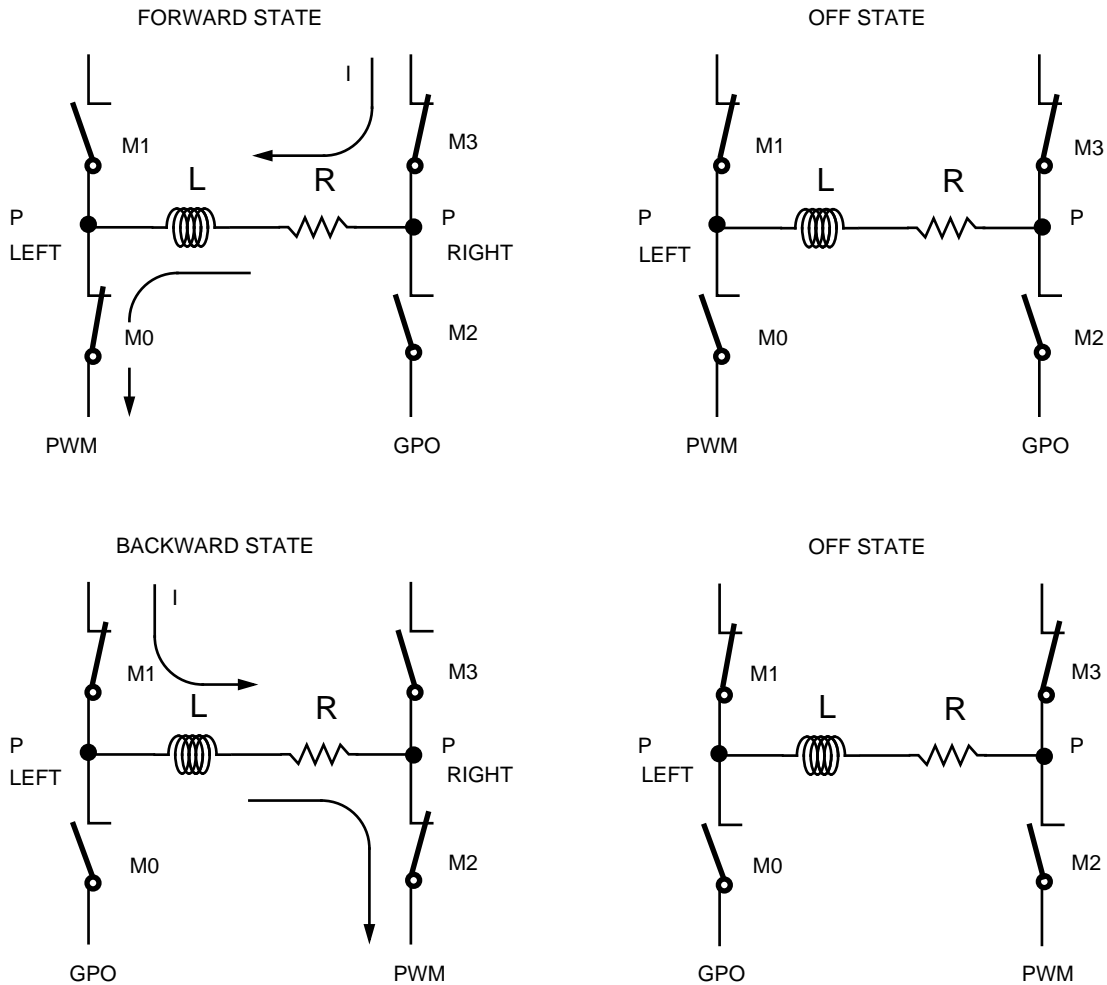
0 = No short circuit at the corresponding port F pin

## 7.7.6 Driver States

A single H-bridge realizes a current through the coil in both directions. Three states are necessary to realize the required H-bridge operations for the 360° aircore instruments.

- Forward State – M1, M2 off; M0, M3 on
- Backward State – M0, M3 off; M1, M2 on
- Off State – M0, M2 off; M1, M3 on

The Mx are the driver transistors which form the H-bridge. The following circuits show how the bridge can operate in the different states. The driver transistors are drawn as switches for simplification.



**Figure 7-11. H-Bridge States**

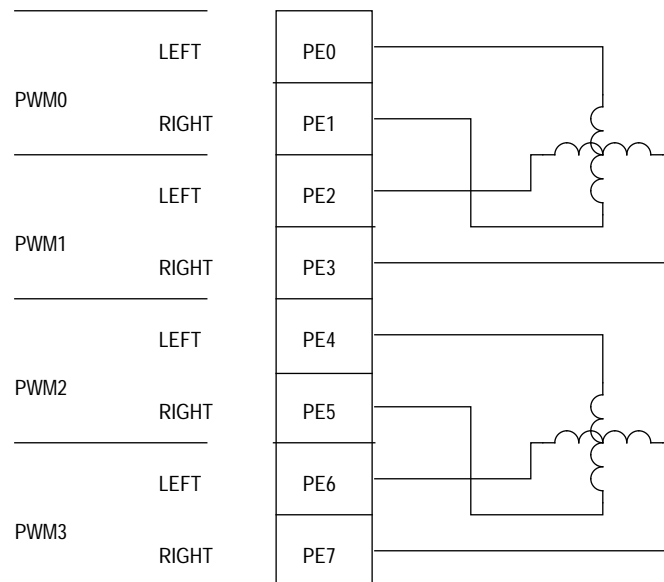
In each state the output driver GPO must hold the output  $P_{\text{left}}$  or  $P_{\text{right}}$  (left or right port line) at voltage  $PV_{DD} - V_{\text{drop}}$  while the PWM driver switches the opposite part of the H-bridge to ground. The PWM driver switches between forward state and off state or backward state and off state. The average current  $I$  is determined by the pulse width ratio at the PWM driver.

Current direction is changed by switching between forward and backward state. The output and the PWM functionality has also been changed between the two port lines when switching current direction.

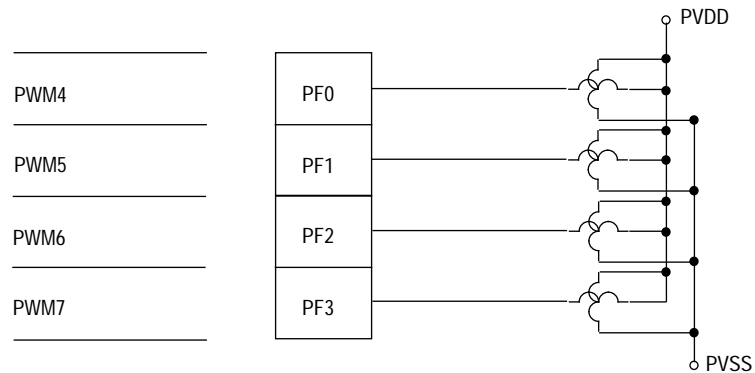
## 7.7.7 Port E and Port F Configurations

**Figure 7-12** shows a port E configuration which controls two 360° aircore instruments or stepper motors. One power driver block controls a single large angle instrument (360°). This configuration ensures a minimum voltage drop mismatch between the two H-bridges of the block.

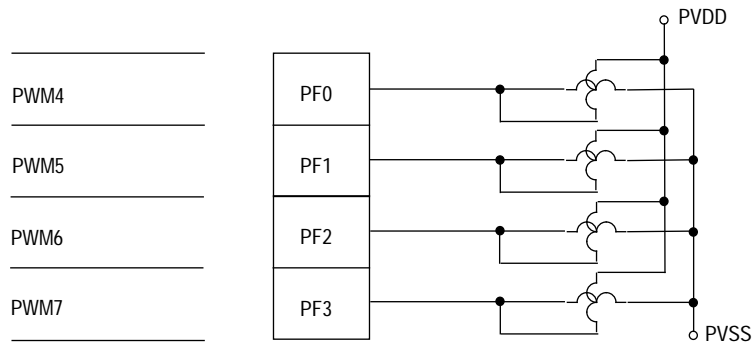
**NOTE:** *One should not control a single instrument with H-bridges from different power driver blocks. The minimum voltage drop mismatch is only ensured within a single block.*



**Figure 7-12. Port E Configuration for two 360° instruments**



**Figure 7-13. Port F Configuration for four 90° instruments (version 1)**



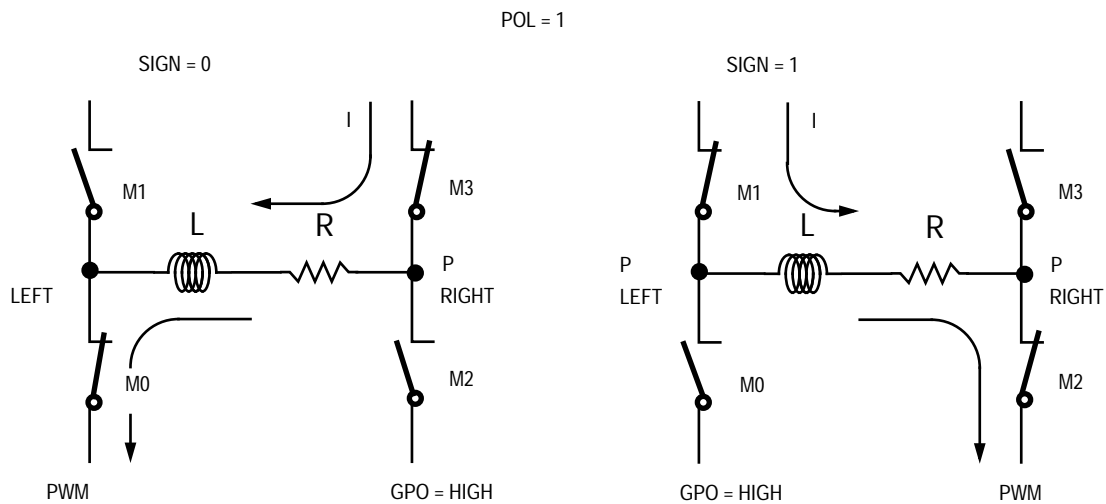
**Figure 7-14. Port F Configuration for four 90° instruments (version 2)**

**Figure 7-13** and **Figure 7-14** show two port F configuration with four 90° small angle instruments which are controlled by the PWM. The small angle instrument does not need a switching between two quadrants. It can be controlled by a single power driver and its PWM.

**NOTE:** *If port E (PWM channels 0 to 3) is used to control small angle instruments, the SIGN bit in the PWM control register may not be changed during the operation with 90° instruments. This would exchange the functionality of PWM and GPO (general purpose output) between the left and the right port bit.*

## 7.7.8 H-Bridge Control with the PWM

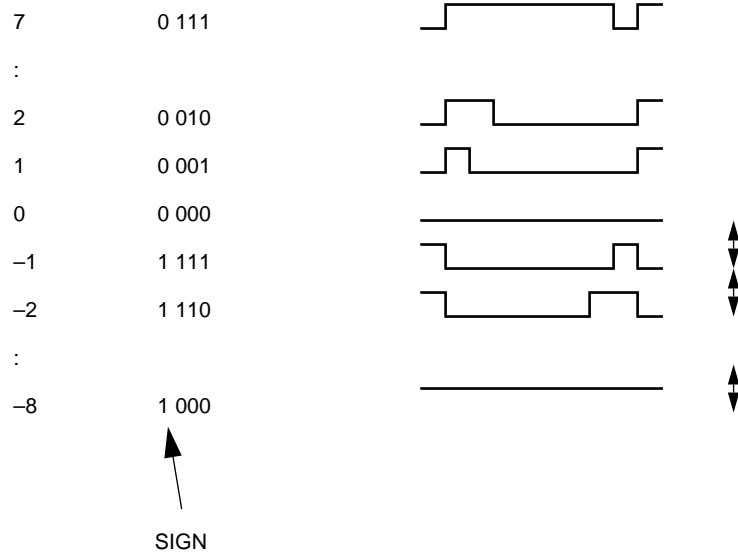
The current in the PWM can be adjusted in the range of  $-I_{\max} \times 256/256$  and  $+I_{\max} \times 255/256$ . The current is a linear function of the 8+1bit 2's complement value in the data register of the PWM channel. The SIGN bit controls the current direction within the H-bridge. This will be done by exchanging the PWM and GPO functionality and inverting the PWM signal in the H-bridge when switching the SIGN-bit.



**Figure 7-15. H-Bridge Control with PWM**

The following 3 bit PWM example in **Figure 7-16** shows the correspondence between the 2's complement values in the data register and the required PWM signal in the H-bridge.





**Figure 7-16. Correspondence between Data and PWM Values**

**Figure 7-16** shows that the PWM signal has to be inverted for the negative values in order to obtain the correct H-bridge signal which is drawn in **Figure 7-16**. (Compare the periods for the values  $-1$  and  $7$ ).

## 7.8 Port E and Port F During WAIT Mode

In WAIT mode a mask option defines if port E and port F will be forced to output 'low' or if port E and port F continue normal operation.

## 7.9 Input/Output Programming

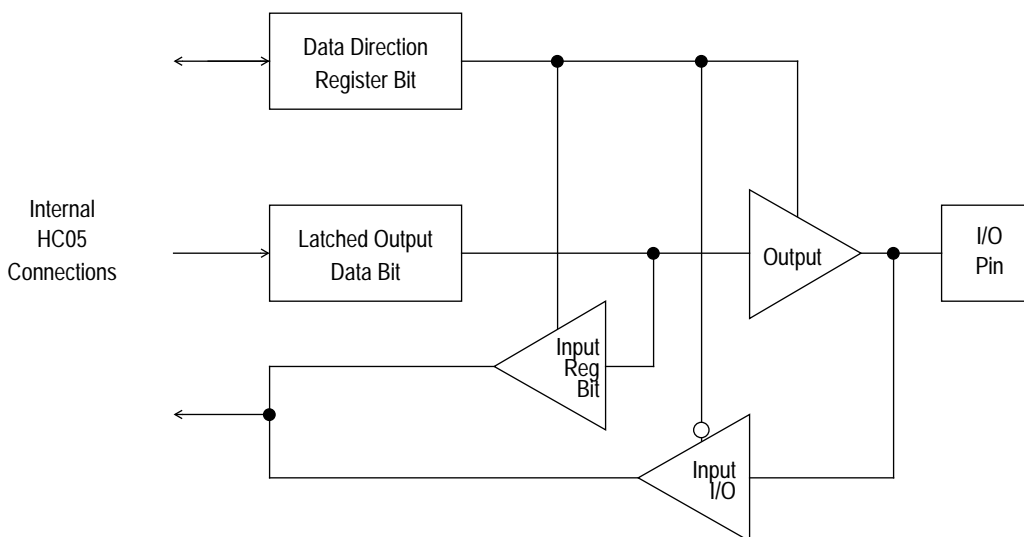
Bidirectional port lines may be programmed as an input or an output under software control. The direction of the pins is determined by the state of the corresponding bit in the port data direction register (DDR). Each port has an associated DDR. Any I/O port pin is configured as an output if its corresponding DDR bit is set to a logic one. A pin is configured as an input if its corresponding DDR bit is cleared to a logical zero.

At power-on or reset, all DDRs are cleared, which configure all port pins as inputs. The data direction registers are capable of being written to or read by the processor. During the programmed output state, a read of the data register actually reads the value of the output data latch and not the I/O pin.

**Table 7-1. I/O Pin Functions**

R/W	DDR	I/O Pin Function
0	0	The I/O pin is in input mode. Data is written into the output data latch.
0	1	Data is written into the output data latch and output to the I/O pin.
1	0	The state of the I/O pin is read.
1	1	The I/O pin is in output mode. The output data latch is read.

$R/\overline{W}$  is an internal signal.



**Figure 7-17. Port I/O Circuitry**

**NOTE:** If the I/O pin is an input and a read-modify (RMW) instruction is executed, the I/O pin will be read into the HC05 CPU and the computed result will then be written to the data latch.

---

**General Release Specification — MC68HC(7)05H12**

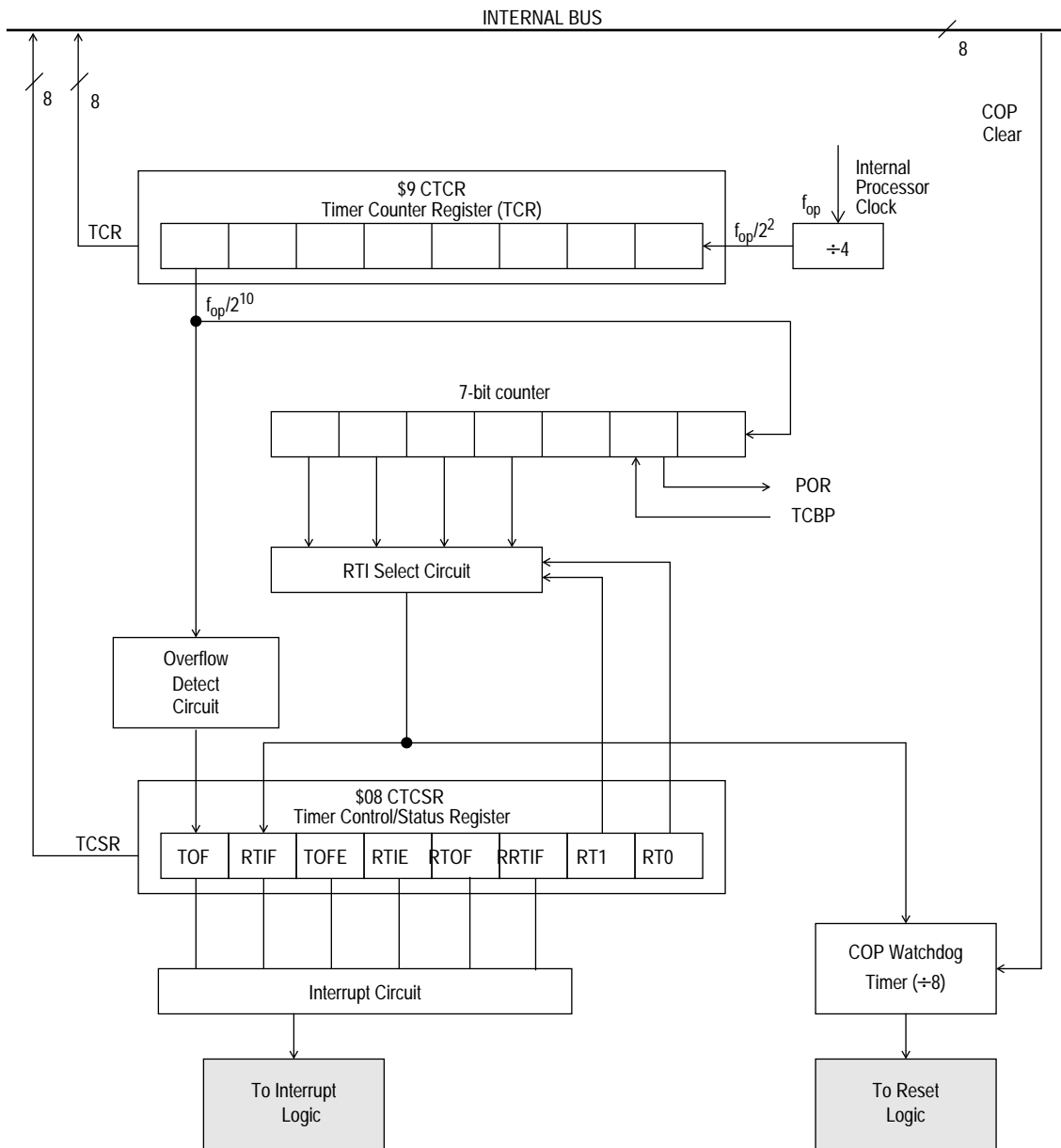
---

**Section 8. Core Timer****8.1 Contents**

8.2	Introduction . . . . .	97
8.3	Registers . . . . .	99
8.3.1	Core Timer Status and Control Register (CTSCR) . . . . .	99
8.3.2	Computer Operating Properly (COP) Watchdog Reset. . .	101
8.3.3	Core Timer Counter Register (CTCR) . . . . .	101
8.4	Core Timer During WAIT . . . . .	102

**8.2 Introduction**

The core timer for this device is a 15-stage multi-functional ripple counter. The features include timer over flow, power-on reset (POR), real time interrupt (RTI), and COP watchdog timer.



**Figure 8-1. Core Timer Block Diagram**

As seen in **Figure 8-1**, the Timer is driven by the output of the clock select circuit followed by a fixed divide by four prescaler. This signal drives an 8-bit ripple counter. The value of this 8-bit ripple counter can be read by the CPU at any time by accessing the timer counter register (TCR) at address \$09. A timer overflow function is implemented on the

last stage of this counter, giving a possible interrupt at the rate of  $f_{op}/1024$ . Two additional stages produce the POR function at  $f_{op}/4064$ . The timer counter bypass circuitry (available only in Test Mode) is at this point in the timer chain. This circuit is followed by two more stages, with the resulting clock ( $f_{op}/16384$ ) driving the real time interrupt circuit. The RTI circuit consists of three divider stages with a 1 of 4 selector. The output of the RTI circuit is further divided by eight to drive the mask optional COP watchdog timer circuit. The RTI rate selector bits, and the RTI and TOF enable bits and flags are located in the timer control and status register at location \$08.

## 8.3 Registers

### 8.3.1 Core Timer Status and Control Register (CTSCR)

The CTSCR contains the timer interrupt flag, the timer interrupt enable bits, and the real time interrupt rate select bits. **Figure 8-2** shows the value of each bit in the CTSCR when coming out of reset.

\$0008	Bit 7	6	5	4	3	2	1	Bit 0
Read:	TOF	RTIF	TOFE	RTIE	0	0	RT!	RT0
Write:					RTOF	RRTIF		
Reset:	0	0	0	0	0	0	1	1

**Figure 8-2. Core Timer Status and Control Register (CTSCR)**

#### TOF – Timer Over Flow

TOF is a read-only status bit and is set when the 8-bit ripple counter rolls over from \$FF to \$00. A CPU interrupt request will be generated if TOFE is set. Reset clears TOF.

#### RTIF – Real Time Interrupt Flag

The real time interrupt circuit consists of a three stage divider and a 1 of 4 selector. The clock frequency that drives the RTI circuit is  $f_{op}/2^{13}$  (or  $f_{op}/8192$ ) with three additional divider stages giving a maximum

interrupt period of about 250ms seconds at a crystal frequency of 1 MHz. RTIF is a read-only status bit and is set when the output of the chosen (1 of 4 selection) stage goes active. A CPU interrupt request will be generated if RTIE is set. Reset clears RTIF.

## TOFE – Timer Over Flow Enable

When this bit is set, a CPU interrupt request is generated when the TOF bit is set. Reset clears this bit.

## RTIE – Real Time Interrupt Enable

When this bit is set, a CPU interrupt request is generated when the RTIF bit is set. Reset clears this bit.

## RTOF — Reset Timer Overflow Flag

This bit reads always as '0'. Writing a '1' to this bit clears the timer overflow flag (TOF). Writing a zero to this bit has no effect.

## RRTIF — Reset Real Time Interrupt Flag

This bit reads always a '0'. Writing a '1' to this bit clears the real time interrupt flag (RTIF). Writing a zero to this bit has no effect.

## RT1, RT0 – Real Time Interrupt Rate Select

These two bits select one of four taps from the real time interrupt circuit. **Figure 8-1** shows the available interrupt rates with several  $f_{op}$  values. Reset sets these RT0 and RT1, selecting the lowest periodic rate and therefore the maximum time in which to alter these bits if necessary. Care should be taken when altering RT0 and RT1 if the time-out period is imminent or uncertain. If the selected tap is modified during a cycle in which the counter is switching, an RTIF could be missed or an additional one could be generated. To avoid problems, the COP should be cleared before changing RTI taps.

**Table 8-1. RTI Rates**

RTI Rates at Bus Frequency $f_{op}$ specified:					
RT1:RT0	500 kHz	1.000 MHz	2.000 MHz	2.4576 MHz	RATIO
00	32.768ms	16.384ms	8.192ms	6.667ms	$2^{14}/f_{op}$

**Table 8-1. RTI Rates**

	RTI Rates at Bus Frequency $f_{OP}$ specified:				
RT1:RT0	500 kHz	1.000 MHz	2.000 MHz	2.4576 MHz	RATIO
01	65.536ms	32.768ms	16.384ms	13.333ms	$2^{15}/f_{op}$
10	131.072ms	65.536ms	32.768ms	26.667ms	$2^{16}/f_{op}$
11	262.144ms	131.072ms	65.536ms	53.333ms	$2^{17}/f_{op}$

### 8.3.2 Computer Operating Properly (COP) Watchdog Reset

The COP watchdog timer function is implemented on this device by using the output of the RTI circuit and further dividing it by eight. The minimum COP reset rates are listed in **Table 8-2**. If the COP circuit times out, an internal reset is generated and the normal reset vector is fetched. Preventing a COP time-out is done by writing a '0' to bit 0 of address \$3FF0. When the COP is cleared, only the final divide by eight stage (output of the RTI) is cleared.

**Table 8-2. Minimum COP Reset Times**

	Minimum COP Reset Bus Frequency at $f_{OP}$ specified:				
RT1:RT0	500 kHz	1.000 MHz	2.000 MHz	2.4576 MHz	RATIO
00	229.376ms	114.689ms	57.344ms	46.666ms	$7*2^{14}/f_{op}$
01	458.752ms	229.376ms	114.689ms	93.333ms	$7*2^{15}/f_{op}$
10	917.504ms	458.752ms	229.376ms	186.666ms	$7*2^{16}/f_{op}$
11	1835.000ms	917.504ms	458.752ms	373.333ms	$7*2^{17}/f_{op}$

### 8.3.3 Core Timer Counter Register (CTCR)

The timer counter register is a read-only register which contains the current value of the 8-bit ripple counter at the beginning of the timer chain. This counter is clocked at  $f_{op}$  divided by 4 and can be used for various functions including a software input capture. Extended time periods can be attained using the TOF function to increment a temporary RAM storage location thereby simulating a 16-bit (or more) counter.

\$0009	Bit 7	6	5	4	3	2	1	Bit 0
Read:	bit 7	bit 6	bit 5	bit 4	bit 3	bit 2	bit 1	bit 0
Write:								
Reset:	0	0	0	0	0	0	0	0

**Figure 8-3. Core Timer Counter Register (CTCR)**

The power-on cycle clears the entire counter chain and begins clocking the counter. After 4064 cycles, the power-on reset circuit is released which again clears the counter chain and allows the device to come out of reset. At this point, if  $\overline{\text{RESET}}$  is not asserted, the timer will start counting up from zero and normal device operation will begin. When  $\overline{\text{RESET}}$  is asserted anytime during operation (other than POR), the counter chain will be cleared.

## 8.4 Core Timer During WAIT

The CPU clock halts during the WAIT mode, but the core timer remains active. If the CTIMER interrupts are enabled, then a CTIMER interrupt will cause the processor to exit the WAIT mode.



## Section 9. 16-Bit Timers

### 9.1 Contents

9.2	Introduction . . . . .	103
9.3	Registers . . . . .	105
9.3.1	Counter . . . . .	105
9.3.2	Output Compare Registers . . . . .	106
9.3.3	Output Compare Register 1 . . . . .	106
9.3.4	Output Compare Register 2 . . . . .	107
9.3.5	Input Capture Registers . . . . .	108
9.3.6	Input Capture Register 1 . . . . .	108
9.3.7	Input Capture Register 2 . . . . .	109
9.3.8	Timer Control Register 1 . . . . .	110
9.3.9	Timer Control Register 2 . . . . .	112
9.3.10	Timer Status Register . . . . .	113
9.4	Timer During WAIT Mode . . . . .	114

### 9.2 Introduction

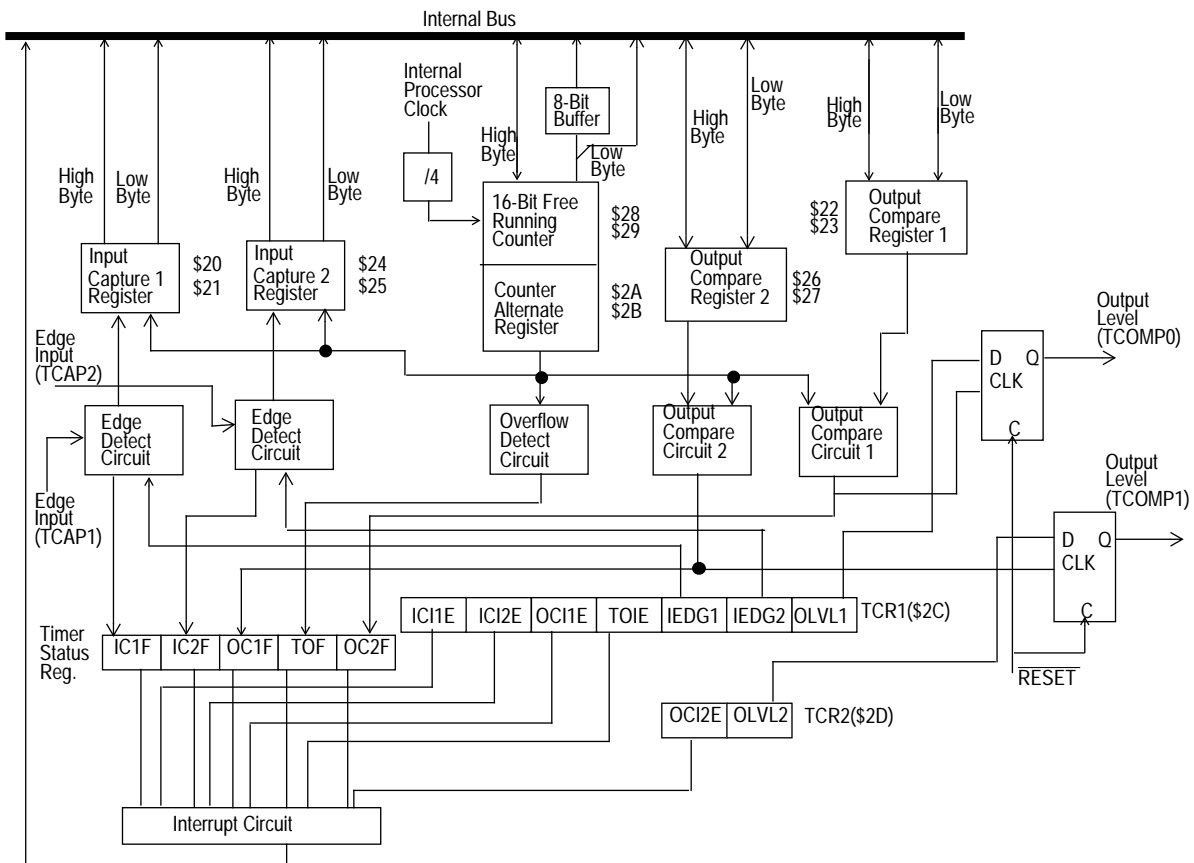
The MC68HC(7)05H12 has two 16-bit timers (Timer1 and Timer2) each with two channels. The output compare function in Timer2 has no external outputs, so it is used for generating precision time intervals and interrupts only. Write access to the corresponding output level register bits OLVL3 and OLVL4 has no effect. Apart from this difference in the external connections, the internal operation of both is identical (each timer having its own set of registers, see **Section 2.3 Registers**), therefore only a complete description of Timer1 is given.

The timer consists of a 16-bit, free running counter driven by a fixed divide-by-four prescaler. This timer can be used for many purposes, including input waveform measurements while simultaneously generating an output waveform. Pulse widths can vary from several

microseconds to many seconds. Refer to **Figure 9-1** for a timer block diagram.

Because the timer has a 16-bit architecture, each specific functional segment (capability) is represented by two registers. These registers contain the high and low byte of that functional segment. Generally, accessing the low byte of a specific timer function allows full control of that function; however, an access of the high byte inhibits that specific timer function until the low byte is also accessed.

**NOTE:** *The I bit in the CCR should be set while manipulating both the high and low byte register of a specific timer function to ensure that an interrupt does not occur.*



**Figure 9-1. Timer Block Diagram (Timer1)**

## 9.3 Registers

Addr	Register Name
\$0020	Timer1 Capture 1 High
\$0021	Timer1 Capture 1 Low
\$0022	Timer1 Compare 1 High
\$0023	Timer1 Compare 1 Low
\$0024	Timer1 Capture 2 High
\$0025	Timer1 Capture 2 Low
\$0026	Timer1 Compare 2 High
\$0027	Timer1 Compare 2 Low
\$0028	Timer1 Counter High
\$0029	Timer1 Counter Low
\$002A	Timer1 Alternate Counter High
\$002B	Timer1 Alternate Counter Low
\$002C	Timer1 Control 1
\$002D	Timer1 Control 2
\$002E	Timer1 Status

**Figure 9-2. 16-Bit Timer Register Addresses (Timer1)**

### 9.3.1 Counter

The key element in the programmable timer is a 16-bit, free-running counter or counter register, preceded by a prescaler that divides the internal processor clock by four. The prescaler gives the timer a resolution of 2.0 microseconds if the internal bus clock is 2.0 MHz. The counter is incremented during the low portion of the internal bus clock. Software can read the counter at any time without affecting its value.

The double-byte, free-running counter can be read from either of two locations, \$28–\$29 (counter register) or \$2A–\$2B (counter alternate register). A read from only the least significant byte (LSB) of the free-running counter (\$29, \$2B) receives the count value at the time of the read. If a read of the free-running counter or counter alternate register first addresses the most significant byte (MSB) (\$28, \$2A), the LSB (\$29, \$2B) is transferred to a buffer. This buffer value remains fixed after the first MSB read, even if the user reads the MSB several times. This buffer is accessed when reading the free-running counter or counter alternate

register LSB (\$29 or \$2B) and thus completes a read sequence of the total counter value. In reading either the free-running counter or counter alternate register, if the MSB is read, the LSB must also be read to complete the sequence.

The counter alternate register differs from the counter register in one respect: a read of the counter register MSB can clear the timer overflow flag (TOF). Therefore, the counter alternate register can be read at any time without the possibility of missing timer overflow interrupts due to clearing of the TOF.

### 9.3.2 Output Compare Registers

There are two output compare registers: output compare register 1 and output compare register 2. Output compare registers can be used for several purposes such as controlling an output waveform or indicating when a period of time has elapsed. All bits are readable and writable and are not altered by the timer hardware or reset. If the compare function is not needed, the two bytes of the output compare register can be used as storage locations.

### 9.3.3 Output Compare Register 1

The 16-bit output compare register 1 is made up of two 8-bit registers at locations \$22 (MSB) and \$23 (LSB). The output compare register contents are compared with the contents of the free-running counter once every four internal processor clock cycles. If a match is found, the output compare flag OC1F (bit 5 of the timer status register (\$2E)) is set and the corresponding output level OLVL1 bit is clocked to TCMP1 output.

The output compare register values and the output level bit should be changed after each successful comparison to establish a new elapsed time-out. An interrupt can also accompany a successful output compare provided the corresponding interrupt enable bit (OC1E) is set.

After a processor write cycle to the output compare register 1 containing the MSB (\$22), the output compare function is inhibited until the LSB

(\$23) is also written. The user must write both bytes (locations) if the MSB is written first. A write made only to the LSB (\$23) will not inhibit the compare function. The free-running counter is updated every four internal bus clock cycles. The minimum time required to update the output compare register is a function of the program rather than the internal hardware.

The processor can write to either byte of the output compare register 1 without affecting the other byte. The output level (OLVL1) bit is clocked to the output level register regardless of whether the output compare flag (OC1F) is set or clear.

Because the output compare flag OC1F and the output compare register 1 are undetermined at power-on and are not affected by external reset, care must be exercised when initializing the output compare function. The following procedure is recommended

Write the high byte to the compare register 1 to inhibit further compares until the low byte is written.

Reading the status register arms the OC1F if it is already set.

Write the output compare register 1 low byte to enable the output compare 1 function with the flag clear.

The purpose of this procedure is to prevent the OC1F bit from being set between the time it is read and the write to the corresponding output compare register.

### 9.3.4 Output Compare Register 2

The 16-bit output compare register 2 is made up of two 8-bit registers at locations \$26 (MSB) and \$27 (LSB). The output compare register contents are compared with the contents of the free-running counter once every four internal processor clock cycles. If a match is found, the output compare flag OC2F (bit 1 of the timer status register (\$2E)) is set and the corresponding output level OLVL2 bit is clocked to TCMP2 output.

The output compare register values and the output level bit should be changed after each successful comparison to establish a new elapsed time-out. An interrupt can also accompany a successful output compare provided the corresponding interrupt enable bit (OC12E) is set.

After a processor write cycle to the output compare register 2 containing the MSB (\$26), the output compare function is inhibited until the LSB (\$27) is also written. The user must write both bytes (locations) if the MSB is written first. A write made only to the LSB (\$27) will not inhibit the compare function. The free-running counter is updated every four internal bus clock cycles. The minimum time required to update the output compare register is a function of the program rather than the internal hardware.

The processor can write to either byte of the output compare register 2 without affecting the other byte. The output level (OLVL2) bit is clocked to the output level register regardless of whether the output compare flag (OC2F) is set or clear.

Because the output compare flag OC2F and the output compare register 2 are undetermined at power-on, and are not affected by external reset care must be exercised when initializing the output compare function. A procedure as recommended for compare register 1 should be followed.

### 9.3.5 Input Capture Registers

There are two identical input capture registers: input capture register 1 and input capture register 2. The two following sections describe these two registers.

#### 9.3.6 Input Capture Register 1

Two 8-bit registers, which make up the 16-bit input capture register 1, are read-only and are used to latch the value of the free-running counter after the corresponding input capture edge detector senses a defined transition on the TCAP1 pin. The level transition which triggers the counter transfer is defined by the corresponding input edge bit (IEDG1). Reset does not affect the contents of the input capture register.

**IEDG1 — Capture on Negative/Positive Edge**

1 = Capture on positive edge

0 = Capture on negative edge

An interrupt can also accompany a capture provided the corresponding interrupt enable bit, IC11E is set.

The result obtained by an input capture will be one more than the value of the free-running counter on the rising edge of the internal bus clock preceding the external transition. This delay is required for internal synchronization. Resolution is one count of the free-running counter, which is four internal bus clock cycles.

The free-running counter contents are transferred to the input capture register on each proper signal transition regardless of whether the input capture flag (IC1F) is set or clear. The input capture register always contains the free-running counter value that corresponds to the most recent input capture.

After a read of the input capture register most significant byte (\$20), the counter transfer is inhibited until the least significant byte (\$21) is also read. This characteristic causes the time used in the input capture software routine and its interaction with the main program to determine the minimum pulse period.

A read of the input capture register LSB (\$21) does not inhibit the free-running counter transfer since they occur on opposite edges of the internal bus clock.

### 9.3.7 Input Capture Register 2

Two 8-bit registers, which make up the 16-bit input capture register 2, are read-only and are used to latch the value of the free-running counter after the corresponding input capture edge detector senses a defined transition on the TCAP2 pin. The level transition which triggers the counter transfer is defined by the corresponding input edge bit (IEDG2). Reset does not affect the contents of the input capture register.

IEDG2 — Capture on Negative/Positive Edge

1 = Capture on positive edge

0 = Capture on negative edge

An interrupt can also accompany a capture provided the corresponding interrupt enable bit, IC12E is set.

The result obtained by an input capture will be one more than the value of the free-running counter on the rising edge of the internal bus clock preceding the external transition. This delay is required for internal synchronization. Resolution is one count of the free-running counter, which is four internal bus clock cycles.

The free-running counter contents are transferred to the input capture register on each proper signal transition regardless of whether the input capture flag (IC2F) is set or clear. The input capture register always contains the free-running counter value that corresponds to the most recent input capture.

After a read of the input capture register most significant byte (\$24), the counter transfer is inhibited until the least significant byte (\$25) is also read. This characteristic causes the time used in the input capture software routine and its interaction with the main program to determine the minimum pulse period.

A read of the input capture register LSB (\$25) does not inhibit the free-running counter transfer since they occur on opposite edges of the internal bus clock.

### 9.3.8 Timer Control Register 1

\$002C	Bit 7	6	5	4	3	2	1	Bit 0
Read:	IC11E	IC12E	OC11E	TOIE	CO1E	IEDG1	IEDG2	OLVL1
Write:								
Reset:	0	0	0	0	0	U	U	0

**Figure 9-3. Timer Control Register 1 (TCR1)**



ICI1E — Input Capture 1 Interrupt Enable

1 = Interrupt enabled

0 = Interrupt disabled

ICI2E — Input Capture 2 Interrupt Enable

1 = Interrupt enabled

0 = Interrupt disabled

OCI1E — Output Compare 1 Interrupt Enable

1 = Interrupt enabled

0 = Interrupt disabled

TOIE — Timer Overflow Interrupt Enable

1 = Interrupt enabled

0 = Interrupt disabled

CO1E — Timer Compare 1 Output Enable

Reset clears this bit.

1 = Output of timer compare 1 is enabled

0 = Output of timer compare 1 is disabled, i.e. held low

IEDG1 — Input Edge

Value of input edge determines which level transition on TCAP1 pin will trigger free-running counter transfer to the input capture register 1.

1 = Positive edge

0 = Negative edge

IEDG2 — Input Edge

Value of input edge determines which level transition on TCAP2 pin will trigger free-running counter transfer to the input capture register 2.

1 = Positive edge

0 = Negative edge

OLVL1 — Output Level 1

Value of output level is clocked into output level register by the next successful output compare 1, and will appear on the TCMP1 pins.

1 = High output

0 = Low output

## 9.3.9 Timer Control Register 2

\$002D	Bit 7	6	5	4	3	2	1	Bit 0
Read:	0	0	OCI2E	0	CO2E	0	0	OLVL2
Write:								
Reset:	U	U	0	0	U	0	0	U

**Figure 9-4. Timer Control Register 2 (TCR2)**

OCI2E — Output Compare 2 Interrupt Enable

- 1 = Interrupt enabled
- 0 = Interrupt disabled

CO2E — Timer Compare 2 Output Enable

Reset clears this bit.

- 1 = Output of timer compare 2 is enabled
- 0 = Output of timer compare 2 is disabled, i.e. held low

OLVL2 — Output Level 2

Value of output level is clocked into output level register by the next successful output compare 2, and will appear on the TCMP2 pin.

- 1 = High output
- 0 = Low output

Bits 1,2,4,6 & 7 of TRC2 are no used and always read zero.

**NOTE:** *Only TCMP1 and TCMP2 of Timer 1 are available at port C, Timer 2 has no TCMP pins.*

### 9.3.10 Timer Status Register

The timer status register is a read-only register containing timer status flags.

\$002E	Bit 7	6	5	4	3	2	1	Bit 0
Read:	IC1F	IC2F	OC1F	TOF	TCAP1	TCAP2	OC2F	0
Write:								
Reset:	U	U	U	U	1	1	U	0

**Figure 9-5. Timer Status Register (TSR)**

**IC1F** — Input Capture 1 Flag

1 = Flag set when selected polarity edge is sensed by input capture 1 edge detector

0 = Flag cleared when TSR and input capture 1 register's low byte is accessed

**IC2F** — Input Capture 2 Flag

1 = Flag set when selected polarity edge is sensed by input capture 2 edge detector

0 = Flag cleared when TSR and input capture 2 register's low byte is accessed

**OC1F** — Output Compare 1 Flag

1 = Flag set when output compare register 1 contents match the free-running counter contents

0 = Flag cleared when TSR and output compare register 1 low byte are accessed

**TOF** — Timer Overflow Flag

1 = Flag set when free-running counter transition from \$FFFF to \$0000 occurs

0 = Flag cleared when TSR and counter low register are accessed

**TCAP1** — Timer Capture 1

This bit reflects the current state of the timer capture 1 input.

**TCAP2** — Timer Capture 2

This bit reflects the current state of the timer capture 2 input.

OC2F — Output Compare 2 Flag

1 = Flag set when output compare register 2 contents match the free-running counter contents

0 = Flag cleared when TSR and output compare register 2 low byte are accessed

Accessing the timer status registers satisfies the first condition required to clear status bits. The remaining step is to access the registers corresponding to the status bit.

A problem can occur when using the timer overflow function and reading the free-running counter at random times to measure an elapsed time. Without incorporating the proper precautions into software, the timer overflow flag could unintentionally be cleared if:

1. The timer status register is read or written when TOF is set, and
2. The LSB of the free-running counter is read but not for the purpose of servicing the flag

The counter alternate register contains the same value as the free-running counter; therefore this alternate register can be read at any time without affecting the timer overflow flag in the timer status register.

### 9.4 Timer During WAIT Mode

The CPU clock halts during the WAIT mode but the timer keeps on running. If a reset is used to exit the WAIT mode the counters are forced to \$FFFC. If interrupts are enabled a timer interrupt will cause the processor to exit WAIT mode.

## Section 10. Serial Peripheral Interface (SPI)

### 10.1 Contents

10.2	Introduction	115
10.3	SPI Signal Description	116
10.3.1	Master In Slave Out (MISO)	116
10.3.2	Master Out Slave In (MOSI)	117
10.3.3	Serial Clock (SCK)	117
10.4	SPI Functional Description	119
10.5	Registers	121
10.5.1	SPI Control Register (SPCR)	121
10.5.2	SPI Status Register (SPSR)	123
10.5.3	SPI Data I/O Register (SPDAT)	124
10.6	SPI During WAIT Mode	124

### 10.2 Introduction

The SPI is a synchronous interface which allows several SPI microcontrollers or SPI-type peripherals to be interconnected. In a serial peripheral interface, separate wires (signals) are required for data and clock. In the SPI format, the clock is not included in the data stream and must be furnished as a separate signal. The MC68HC(7)05H12 SPI system may be configured either as a master or as a slave.

Features include:

- Full-duplex, 3-wire synchronous transfers
- Master or slave operation
- 2.50 MHz (maximum) master bit frequency
- 5.0 MHz (maximum) slave bit frequency
- Four programmable master bit rates
- Programmable clock polarity and phase
- End-of-transmission interrupt flag
- Write collision flag protection
- Master-master mode fault protection
- Easy interface to simple expansion parts (PLLs, D/As, latches, display drivers, etc.)
- Very low clock rates by reuse of the SCI prescalers.

### 10.3 SPI Signal Description

Three I/O pins located at port B are associated with the SPI data transfers. They are the serial clock (SCK), the master in/slave out (MISO) data line, the master out/slave in (MOSI) data line. When the SPI system is not utilized (SPE bit cleared in the serial peripheral control register), the three pins (MISO, MOSI, SCK) are configured as general-purpose I/O pins. The three SPI signals are discussed in the following paragraphs for both master mode and slave mode of operation.

**NOTE:** *The SPI subsystem works as master and does not have a slave select input line (SS).*

#### 10.3.1 Master In Slave Out (MISO)

The MISO line is configured as an input in a master device and as an output in a slave device. It is one of the two lines that transfer serial data in one direction, with the most significant bit sent first. The MISO line of a slave device is placed in the high-impedance state if the slave is not selected.

### 10.3.2 Master Out Slave In (MOSI)

The MOSI line is configured as an output in a master device and as an input in a slave device. It is one of the two lines that transfer serial data in one direction with the most significant bit sent first.

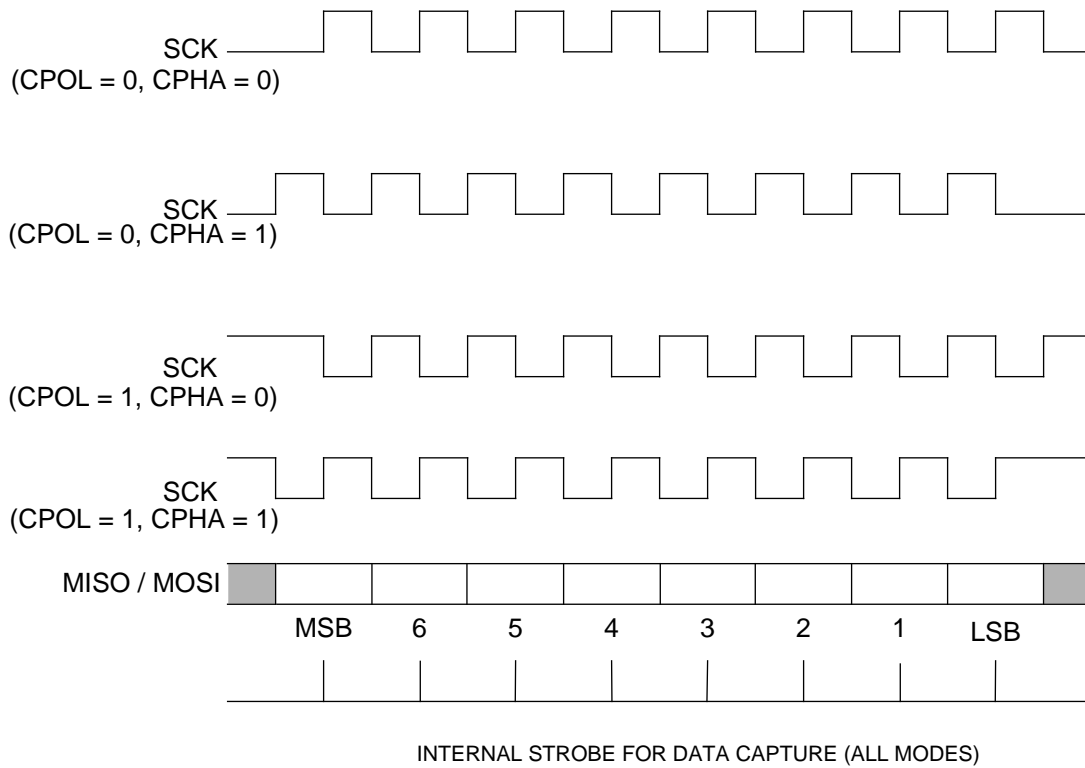
### 10.3.3 Serial Clock (SCK)

The serial clock is used to synchronize data movement both in and out of the device through its MOSI and MISO lines. The master and slave devices are capable of exchanging a byte of information during a sequence of eight clock cycles. Since SCK is generated by the master device, this line becomes an input on a slave device.

As shown in **Figure 10-1**, four different timing relationships may be selected by control bits CPOL and CPHA in the serial peripheral control register (SPCR). Both master and slave devices must operate with the same timing. The master device always places data on the MOSI line a half cycle before the clock edge (SCK), in order for the slave device to latch the data.

Two bits (SPR0 and SPR1) in the SPCR of the master device select the clock rate. In a slave device, SPR0 and SPR1 have no effect on the operation of the SPI.

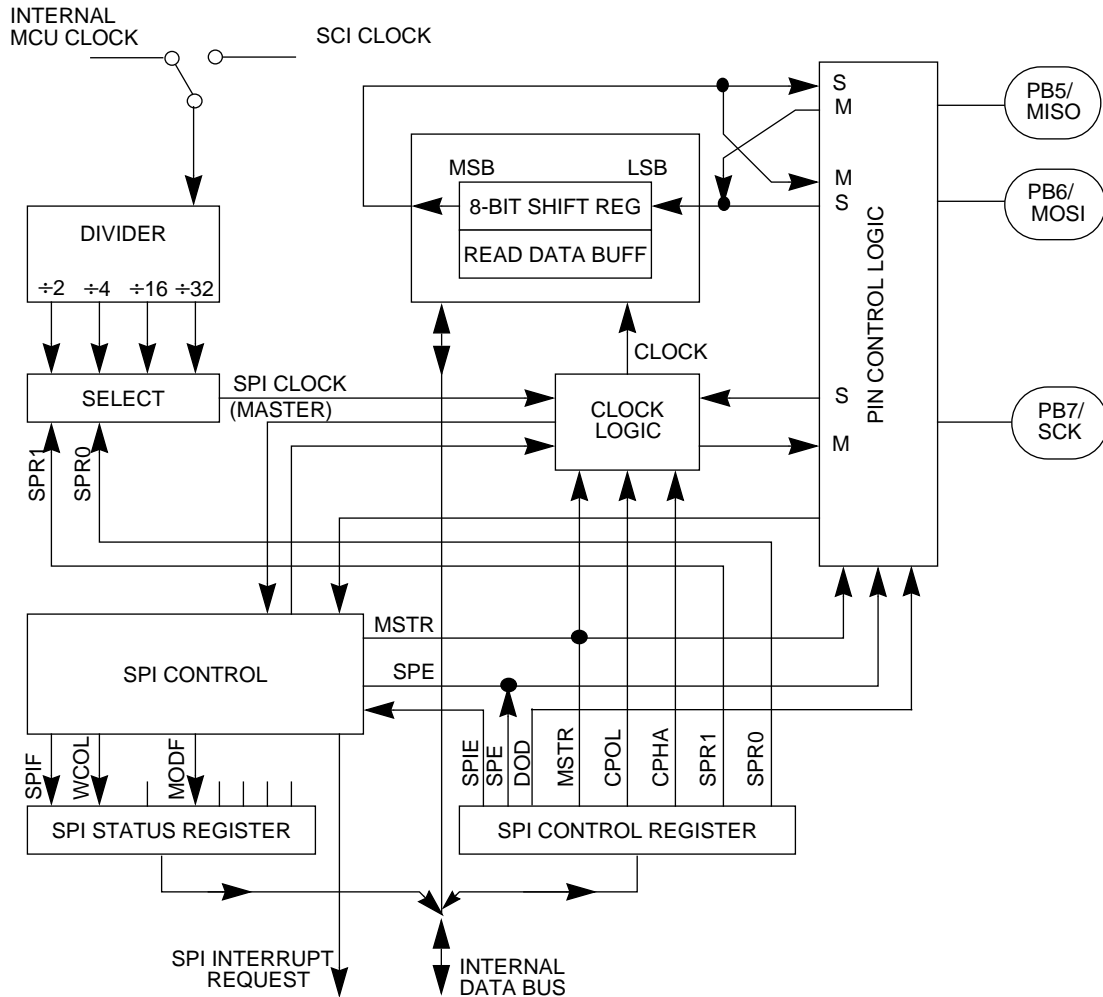
# Serial Peripheral Interface (SPI)



**Figure 10-1. Data Clock Timing Diagram**



## 10.4 SPI Functional Description



**Figure 10-2. Serial Peripheral Block Diagram**

**Figure 10-2** shows a block diagram of the serial peripheral interface circuitry. When a master device transmits data to a slave device via the MOSI line, the slave device responds by sending data to the master device via the master's MISO line. This implies full duplex transmission with both data out and data in synchronized to the same clock signal. Thus, the byte transmitted is replaced by the byte received and eliminates the need for separate transmitter-empty and receiver-full

## Serial Peripheral Interface (SPI)

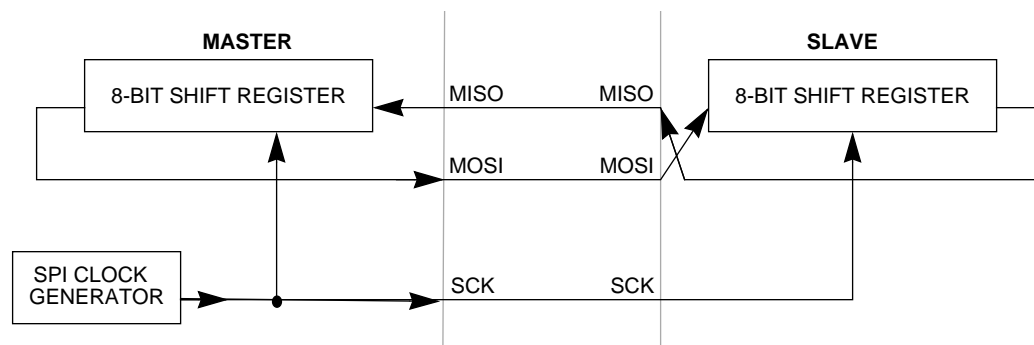
status bits. A single status bit (SPIF) is used to signify that the I/O operation has been completed.

The SPI is double buffered on read, but not on write. If a write is performed during data transfer, the transfer is not interrupted, and the write will be unsuccessful. This condition will cause the write collision status bit (WCOL) in the SPSR to be set. After a data byte is shifted, the SPIF flag in the SPSR is set.

In master mode, the SCK pin is an output. It idles high or low, depending on the CPOL bit in the SPCR, until data is written to the shift register. Then eight clocks are generated to shift the eight bits of data, after which SCK goes idle again.

In slave mode, the slave start logic receives a clock input at the SCK pin. Thus, the slave is synchronized to the master. Data from the master is received serially via the slave MOSI line and is loaded into the 8-bit shift register. The data is then transferred, in parallel, from the 8-bit shift register to the read buffer. During a write cycle, data is written into the shift register, then the slave waits for a clock train from the master to shift the data out on the slave's MISO line.

**Figure 10-3** illustrates the MOSI, MISO and SCK master-slave interconnections.



**Figure 10-3. Serial Peripheral Interface Master-Slave Interconnection**

## 10.5 Registers

There are three registers in the serial peripheral interface which provide control, status and data storage functions. These registers are called the serial peripheral control register (SPCR), the serial peripheral status register (SPSR) and the serial peripheral data I/O register (SPDAT).

### 10.5.1 SPI Control Register (SPCR)

\$0044	Bit 7	6	5	4	3	2	1	Bit 0
Read:	SPIE	SPE	DOD	MSTR	CPOL	CPHA	SPR1	SPR0
Write:								
Reset:	0	0	0	0	0	1	U	U

**Figure 10-4. SPI Control Register (SPCR)**

#### SPIE — SPI Interrupt Enable

When this bit is set to one, a hardware interrupt sequence is requested each time the SPIF or MODF status flag is set. SPI interrupts are inhibited if this bit is clear or if the I bit in the CC Register is set.

- 1 = SPI interrupts enabled
- 0 = SPI interrupts disabled

#### SPE — SPI System Enable

- 1 = SPI system on
- 0 = SPI system off

#### DOD — Direction of Data Flow (in or out of the Serial Shift Register)

- 1 = data is transferred LSB first
- 0 = data is transferred MSB first

#### MSTR — Master/Slave Mode Select

- 1 = Master mode
- 0 = Slave mode

## CPOL — Clock Polarity

When the clock polarity bit is cleared and data is not being transferred, a steady state low value is produced at the SCK pin of the master device. Conversely, if this bit is set, the SCK pin will idle high. This bit is also used in conjunction with the clock phase control bit to produce the desired clock-data relationship between master and slave. See **Figure 10-1**.

## CPHA — Clock Phase

The clock phase bit, in conjunction with the CPOL bit, controls the clock-data relationship between master and slave. The CPOL bit can be thought of simply as inserting an inverter in series with the SCK line. The CPHA bit selects one of two fundamentally different clocking protocols. Refer to **Figure 10-1**.

## SPR1, SPR0 — SPI Clock Rate Selects

If the device is a master, the two serial peripheral rate bits select one of four division ratios of the input-clock to be used as SCK (see **Table 10-1**). These bits have no effect in slave mode.

**Table 10-1. SPI Clock Rate Selection**

SPR1	SPR0	Input clock divided by PRS0
0	0	2
0	1	4
1	0	16
1	1	32

Bit 6 (SPP = SPI Prescaler) of the SCI baud rate register, **Section 11.8.5 Baud Rate Register (BAUD)**, determines the input clock of the SPI module.

## SPP — SPI Prescaler

- 1 = SCI receiver clock connected to the SPI clock input
- 0 = bus clock connected to the SPI clock input

**NOTE:** *If SPP is set, the SPI clock rate is dependent on the SCI clock rate. The SPI clock rate is given by E: PRS1: PRS2: PRS0. PRS1 and PRS2 are*

the SCI prescaler factors given in **Table 11-1** and **Table 11-2**. PRS0 is the SPI prescaler factor given in **Table 10-1**.

### 10.5.2 SPI Status Register (SPSR)

\$0045	Bit 7	6	5	4	3	2	1	Bit 0
Read:	SPIF	WCOL	0	0	0	0	0	0
Write:								
Reset:	0	0	0	0	0	0	0	0

**Figure 10-5. SPI Status Register (SPSR)**

#### SPIF — SPI Interrupt Request Flag

The serial peripheral data transfer flag bit is set after the eighth SCK cycle in a data transfer and it is cleared by reading the SPSR register (with SPIF set) followed by reading from or writing to the SPI Data Register (SPDAT).

#### WCOL — Write Collision

The write collision bit is used to indicate that a serial transfer was in progress when the MCU tried to write new data into the SPDAT data register. The MCU write is disabled to avoid writing over the data being transmitted. No interrupt is generated because the error status flag can be read upon completion of the transfer that was in progress at the time of the error. This flag is automatically cleared by a read of the SPSR (with WCOL set) followed by an access (read or write) to the SPDAT register.

## 10.5.3 SPI Data I/O Register (SPDAT)

\$0046	Bit 7	6	5	4	3	2	1	Bit 0
Read:	bit 7	bit 6	bit 5	bit 4	bit 3	bit 2	bit 1	bit 0
Write:								
Reset:	U	U	U	U	U	U	U	U

**Figure 10-6. SPI Data I/O Register (SPDAT)**

The serial peripheral data I/O register is used to transmit and receive data on the serial bus. Only a write to this register will initiate transmission/reception of another byte, and this will only occur in the master device. At the completion of transmitting a byte of data, the SPIF status bit is set in both the master and slave devices.

When the user reads the serial peripheral data I/O register, a buffer is actually being read. The first SPIF must be cleared by the time a second transfer of data from the shift register to the read buffer is initiated or an overrun condition will exist. In cases of overrun, the byte which causes the overrun is lost.

A write to the serial peripheral data I/O register is not buffered and places data directly into the shift register for transmission.

## 10.6 SPI During WAIT Mode

When the MCU enters wait mode, the CPU clock is halted. All CPU action is suspended; however, the SPI system remains active. In fact an interrupt from the SPI causes the processor to exit the wait mode.

## Section 11. Serial Communications Interface (SCI)

### 11.1 Contents

11.2	Introduction . . . . .	125
11.3	Data Format . . . . .	130
11.4	Receiver Wake-up Operation . . . . .	130
11.4.1	Idle Line Wake-up . . . . .	131
11.4.2	Address Mark Wake-up . . . . .	131
11.5	Receive Data (RDI) . . . . .	132
11.6	Start Bit Detection . . . . .	132
11.7	Transmit Data (TDO) . . . . .	135
11.8	Registers . . . . .	135
11.8.1	Serial Communications Data Register (SCDAT) . . . . .	135
11.8.2	Serial Communications Control Register 1 (SCCR1) . . . . .	136
11.8.3	Serial Communications Control Register 2 (SCCR2) . . . . .	137
11.8.4	Serial Communications Status Register (SCSR) . . . . .	138
11.8.5	Baud Rate Register (BAUD) . . . . .	140
11.9	SCI During WAIT Mode . . . . .	142

### 11.2 Introduction

The SCI is a full-duplex UART-type asynchronous system, using standard non return-to-zero (NRZ) format (one start bit, eight or nine data bits, and a stop bit). An on-chip baud-rate generator derives standard baud-rate frequencies from the MCU oscillator. Both the transmitter and the receiver are double buffered; thus, back-to-back characters can be handled easily, even if the central processing unit (CPU) is delayed in responding to the completion of an individual character. The SCI transmitter and receiver are functionally independent but use the same format and baud rate.

### SCI Two-wire System Features:

- Standard NRZ (mark/space) format.
- Advanced error detection method includes noise detection for noise duration of up to 1/16th bit time.
- Full-duplex operation.
- Software programmable for one of 32 different baud rates.
- Software selectable word length (eight or nine bit words).
- Separate transmitter and receiver enable bits.
- Capable of being interrupt driven.
- Four separate enable bits available for interrupt control.

### SCI Receiver Features:

- Receiver wake-up function (idle line or address bit).
- Idle line detect.
- Framing error detect.
- Noise detect.
- Overrun detect.
- Receiver data register full flag.

### SCI Transmitter Features:

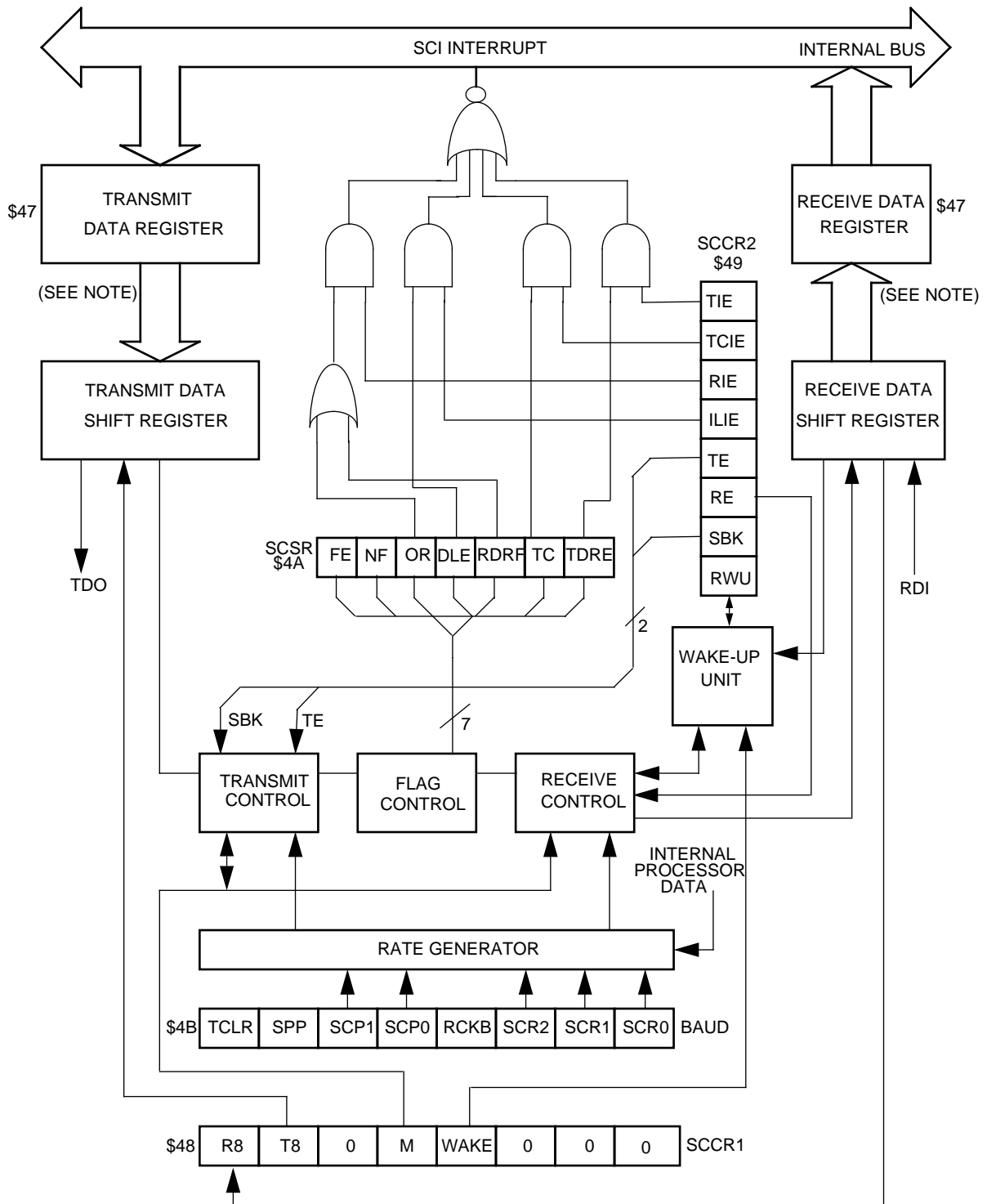
- Transmit data register empty flag.
- Transmit complete flag.
- Send break.

A block diagram of the SCI is shown in **Figure 11-1**. The user has option bits in serial communication control register 1 (SCCR1) to select the 'wake-up' method (WAKE bit) and data word length (M bit) of the SCI. Serial communications control register 2 (SCCR2) provides control bits which individually enable/disable the transmitter or receiver (TE and RE, respectively), enable system interrupts (TIE, TCIE, RIE, ILIE) and provide the wake-up enable bit (RWU) and the send break code bit



(SBK). Control bits in the baud rate register (BAUD) allow the user to select one of 32 different baud rates for the transmitter and receiver.

# Serial Communications Interface (SCI)



**Figure 11-1. Serial Communications Interface Block Diagram**

**NOTE:** *The Serial Communications Data Register (SCDAT) is controlled by the internal  $R/\bar{W}$  signal. It is the transmit data register when written and the receive data register when read.*

Data transmission is initiated by a write to the serial communications data register (SCDR). Provided the transmitter is enabled, data stored in the SCDR is transferred to the transmit data shift register. This transfer of data sets the transmit data register empty flag (TDRE) in the SCI status register (SCSR) and may generate an interrupt if the transmit interrupt is enabled. The transfer of data to the transmit data shift register is synchronized with the bit rate clock. All data is transmitted least significant bit first. Upon completion of data transmission, the transmission complete flag (TC) in the SCSR is set (provided no pending data, preamble or break is to be sent), and an interrupt may be generated if the transmit complete interrupt is enabled. If the transmitter is disabled, and the data, preamble or break (in the transmit data shift register) has been sent, the TC bit will also be set. This will also generate an interrupt if the transmission complete interrupt enable bit (TCIE) is set. If the transmitter is disabled in the middle of a transmission, that character will be completed before the transmitter gives up control of the TDO pin.

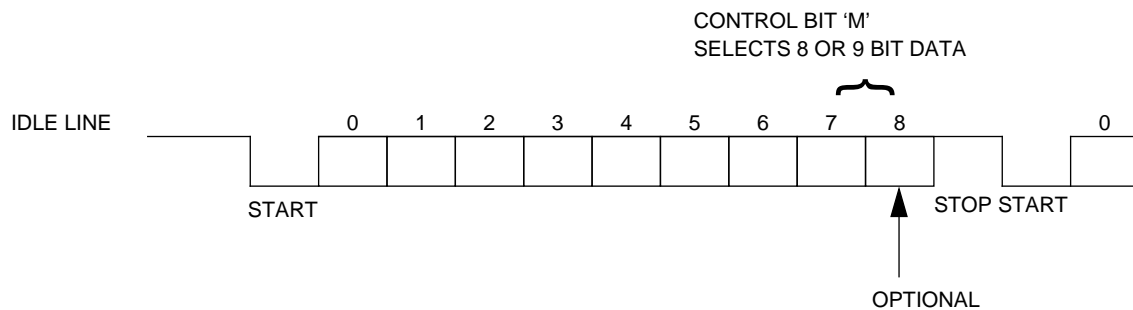
When SCDR is read, it contains the last data byte received, provided that the receiver is enabled. The receive data register full flag bit (RDRF) in the SCSR is set to indicate that a data byte has been transferred from the input serial shift register to the SCDR, which can cause an interrupt if the receiver interrupt is enabled. The data transfer from the input serial shift register to the SCDR is synchronized by the receiver bit rate clock. The OR (overrun), NF (noise), or FE (framing) error flags in the SCSR may be set if data reception errors occurred.

An idle line interrupt is generated if the idle line interrupt is enabled and the IDLE bit (which detects idle line transmission) in SCSR is set. This allows a receiver that is not in the wake-up mode to detect the end of a message or the preamble of a new message, or to resynchronize with the transmitter. A valid character must be received before the idle line condition or the IDLE bit will not be set and idle line interrupt will not be generated.

## 11.3 Data Format

Receive data or transmit data is the serial data that is transferred to the internal data bus from the receive data input pin (RDI) or from the internal bus to the transmit data output pin (TDO). The non-return-to-zero (NRZ) data format shown in **Figure 11-2** is used and must meet the following 5 criteria:

1. The idle line is brought to a logic one state prior to transmission/reception of a character.
2. A start bit (logic zero) is used to indicate the start of a frame.
3. The data is transmitted and received least significant bit first.
4. A stop bit (logic one) is used to indicate the end of a frame. A frame consists of a start bit, a character of eight or nine data bits, and a stop bit.
5. A break is defined as the transmission or reception of a low (logic zero) for at least one complete frame time.



**Figure 11-2. Data Format**

## 11.4 Receiver Wake-up Operation

The receiver logic hardware also supports a receiver wake-up function which is intended for systems having more than one receiver. With this function a transmitting device directs messages to an individual receiver or group of receivers by passing addressing information as the initial byte(s) of each message. The wake-up function allows receivers not

addressed to remain in a dormant state for the remainder of the unwanted message. This eliminates any further software overhead to service the remaining characters of the unwanted message and thus improves system performance.

The receiver is placed in wake-up mode by setting the receiver wake-up bit (RWU) in the SCCR2 register. While RWU is set, all of the receiver related status flags (RDRF, IDLE, OR, NF, and FE) are inhibited (cannot become set). Note that the idle line detect function is inhibited while the RWU bit is set. Although RWU may be cleared by a software write to SCCR2, it would be unusual to do so. Normally RWU is set by software and gets cleared automatically with hardware by one of the two methods described below.

#### 11.4.1 Idle Line Wake-up

In idle line wake-up mode, a dormant receiver wakes up as soon as the RDI line becomes idle. Idle is defined as a continuous logic high level on the RDI line for ten (or eleven) full bit times. Systems using this type of wake-up must provide at least one character time of idle between messages to wake up sleeping receivers, but must not allow any idle time between characters within a message.

#### 11.4.2 Address Mark Wake-up

In address mark wake-up, the most significant bit (MSB) in a character is used to indicate that the character is an address (1) or a data (0) character. Sleeping receivers will wake up whenever an address character is received. Systems using this method for wake-up would set the MSB of the first character of each message and leave it clear for all other characters in the message. Idle periods may be present within messages and no idle time is required between messages for this wake-up method.

## 11.5 Receive Data (RDI)

Receive data is the serial data that is applied through the input line and the serial communications interface to the internal bus. The receiver circuitry clocks the input at a rate equal to 16 times the baud rate and this time is referred to as the RT clock.

Once a valid start bit is detected the start bit, each data bit and the stop bit are sampled three times at RT intervals 8 RT, 9 RT and 10 RT (1 RT is the position where the bit is expected to start), as shown in **Figure 11-3**. The value of the bit is determined by voting logic which takes the value of the majority of the samples.

PREVIOUS BIT		PRESENT BIT		SAMPLES			NEXT BIT	
RDI				V	V	V		
16	1			8	9	10	16	1
R	R			R	R	R	R	R
T	T			T	T	T	T	T

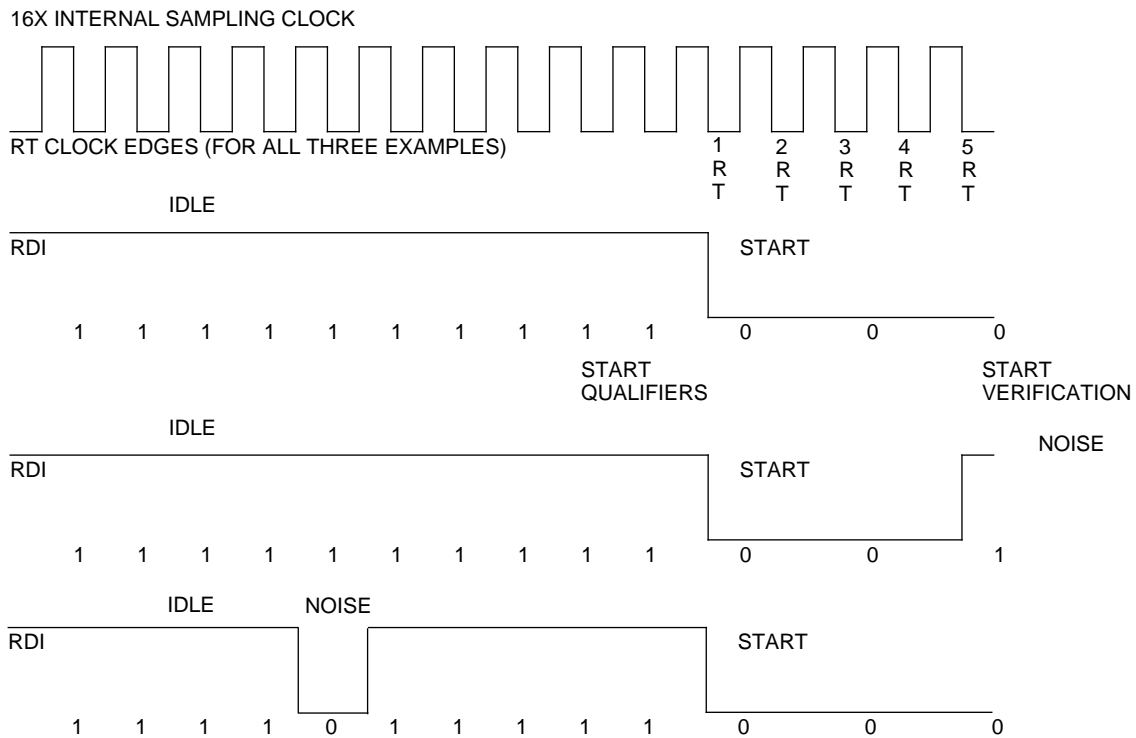
**Figure 11-3. Sampling Technique Used On All Bits**

## 11.6 Start Bit Detection

When the RDI input is detected low, it is tested for three more sample times (referred to as the start edge verification samples in **Figure 11-4**). If at least two of these three verification samples detect a logic zero, a valid start bit has been detected, otherwise the line is assumed to be idle. A noise flag is set if all three verification samples do not detect a logic zero. A valid start bit could be assumed with a set noise flag present.

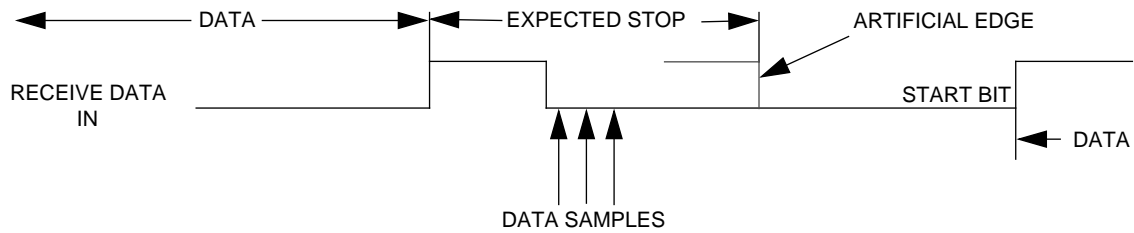
If there has been a framing error without detection of a break (10 zeros for 8-bit format or 11 zeros for 9-bit format), the circuit continues to operate as if there actually was a stop bit and the start edge will be placed artificially. The last bit received in the data shift register is

inverted to a logic one, and the three logic one start qualifiers (shown in **Figure 11-4**) are forced into the sample shift register during the interval when detection of a start bit is anticipated (see **Figure 11-5**); therefore, the start bit will be accepted no sooner than it is anticipated. If the receiver detects that a break produced the framing error, the start bit will not be artificially induced and the receiver must actually detect a logic one before the start bit can be recognised (see **Figure 11-6**).

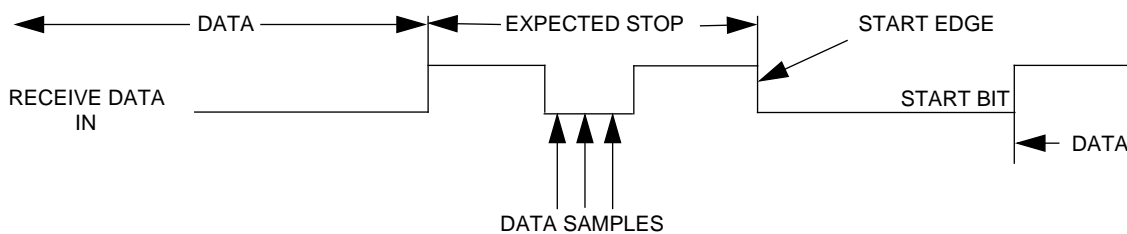


**Figure 11-4. Examples of Start Bit Sampling Techniques**

# Serial Communications Interface (SCI)

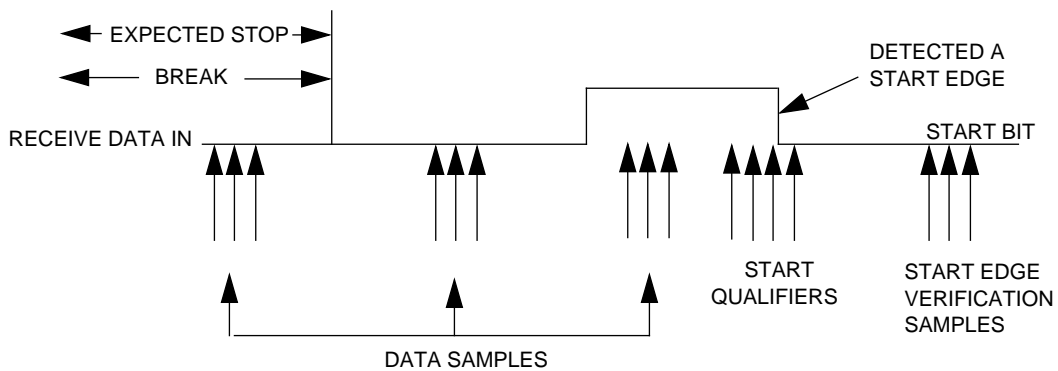


(A) CASE 1, RECEIVE LINE LOW DURING ARTIFICIAL EDGE



(B) CASE 2, RECEIVE LINE HIGH DURING EXPECTED START EDGE

**Figure 11-5. SCI Artificial Start Following a Framing Error**



**Figure 11-6. SCI Start Bit Following a Break**



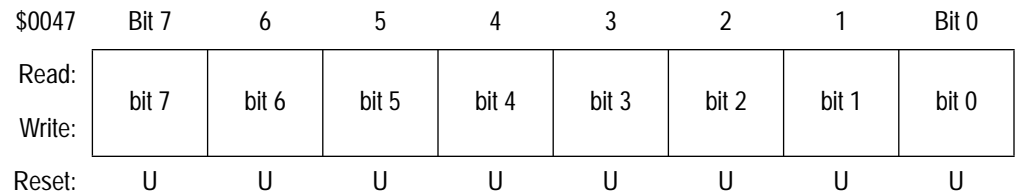
## 11.7 Transmit Data (TDO)

Transmit data is the serial data from the internal data bus that is applied through the serial communications interface to the output line. The transmitter generates a bit time by using a derivative of the RT clock, thus producing a transmission rate equal to 1/16th that of the receiver sample clock.

## 11.8 Registers

Primarily the SCI system is configured and controlled by five registers BAUD, SCCR1, SCCR2, SCSR, and SCDAT.

### 11.8.1 Serial Communications Data Register (SCDAT)



**Figure 11-7. SCI Data Register (SCDAT)**

The SCI data register (SCDAT) shown in **Figure 11-7** is actually two separate registers. When SCDAT is read, the read-only receive data register is accessed and when SCDAT is written, the write-only transmit data register is accessed.

## 11.8.2 Serial Communications Control Register 1 (SCCR1)

\$0048	Bit 7	6	5	4	3	2	1	Bit 0
Read:	R8	T8	0	M	WAKE	0	0	0
Write:								
Reset:	U	U	U	U	U	U	U	U

**Figure 11-8. SCI Control Register 1 (SCCR1)**

### R8 — Receive Data Bit 8

This bit is the ninth serial data bit received when the SCI system is configured for nine data bit operation ( $M = 1$ ). The most significant bit (bit 8) of the received character is transferred into this bit at the same time as the remaining eight bits (bits 0 – 7) are transferred from the serial receive shift register to the SCI receive data register.

### T8 — Transmit Data Bit 8

This bit is the ninth data bit to be transmitted when the SCI system is configured for nine data bit operation ( $M = 1$ ). When the eight low order bits (bits 0–7) of a transmit character are transferred from the SCI data register to the serial transmit shift register, this bit (bit 8) is transferred to the ninth bit position of the shift register.

### M — Mode (Select Character Format)

The M bit controls the character length for both the transmitter and receiver at the same time. The 9th data bit is most commonly used as an extra stop bit or in conjunction with the “address mark” wake-up method. It can also be used as a parity bit.

- 1 = 1 start bit, 8 data bits + 9th data bit, 1 stop bit
- 0 = 1 start bit, 8 data bits, 1 stop bit

### WAKE — Wake-up Mode Select

- 1 = Wake-up on address mark
- 0 = Wake-up on idle line

### 11.8.3 Serial Communications Control Register 2 (SCCR2)

The SCI control register 2 (SCCR2) provides the control bits that enable/disable individual SCI functions.

\$0049	Bit 7	6	5	4	3	2	1	Bit 0
Read:	TIE	TCIE	RIE	ILIE	TE	RE	RWU	SBK
Write:								
Reset:	0	0	0	0	0	0	0	0

**Figure 11-9. SCI Control Register 2 (SCCR2)**

**TIE** — Transmit Interrupt Enable

- 1 = SCI interrupt if TDRE = 1
- 0 = TDRE interrupts disabled

**TCIE** — Transmit Complete Interrupt Enable

- 1 = SCI interrupt if TC = 1
- 0 = TC interrupts disabled

**RIE** — Receiver Interrupt Enable

- 1 = SCI interrupt if RDRF or OR = 1
- 0 = RDRF and OR interrupts disabled

**ILIE** — Idle Line Interrupt Enable

- 1 = Idle Line Interrupt Enable
- 0 = IDLE interrupts disabled

**TE** — Transmitter Enable

When the transmit enable bit is set, the transmit shift register output is applied to the TDO line. Depending on the state of control bit M (SCCR1), a preamble of 10 (M = 0) or 11 (M = 1) consecutive ones is transmitted when software sets the TE bit from a cleared state. After loading the last byte in the serial communications data register and receiving the TDRE flag, the user can clear TE. Transmission of the last byte will then be completed before the transmitter gives up control of the TDO pin. While the transmitter is active, the Port C bit 7 line is forced to be an output.

## Serial Communications Interface (SCI)

### RE — Receiver Enable

When the receiver enable bit is set, the receiver is enabled. When RE is clear, the receiver is disabled and all of the status bits associated with the receiver (RDRF, IDLE, OR, NF and FE) are inhibited. While the receiver is enabled, the Port C bit 6 is forced to be an input.

### RWU — Receiver Wake-up

When the receiver wake-up bit is set by the user software, it puts the receiver to sleep and enables the wake-up function. If the WAKE bit is cleared, RWU is cleared by the SCI logic after receiving 10 ( $M = 0$ ) or 11 ( $M = 1$ ) consecutive ones. If the WAKE bit is set, RWU is cleared by the SCI logic after receiving a data word whose MSB is set.

### SBK — Send Break

If the send break bit is toggled set and cleared, the transmitter sends 10 ( $M = 0$ ) or 11 ( $M = 1$ ) zeros and then reverts to idle sending data. If SBK remains set, the transmitter will continually send whole blocks of zeros (sets of 10 or 11) until cleared. At the completion of the break code, the transmitter sends at least one high bit to guarantee recognition of a valid start bit. If the transmitter is currently empty and idle, setting and clearing SBK is likely to queue two character times of break because the first break transfers almost immediately to the shift register and the second is then queued into the parallel transmit buffer.

### 11.8.4 Serial Communications Status Register (SCSR)

The serial communications status register (SCSR) provides inputs to the interrupt logic circuits for generation of the SCI system interrupt.

\$004A	Bit 7	6	5	4	3	2	1	Bit 0
Read:	TDRE	TC	RDRF	IDLE	OR	NF	FE	0
Write:								
Reset:	1	1	0	0	0	0	0	0

**Figure 11-10. SCI Status Register (SCSR)**

#### TDRE — Transmit Data Register Empty Flag

This bit is set when the byte in the transmit data register is transferred to the serial shift register. New data will not be transmitted unless the SCSR register is read before writing to the transmit data register. Reset sets this bit.

#### TC — Transmit Complete Flag

This bit is set to indicate that the SCI transmitter has no meaningful information to transmit (no data in shift register, no preamble, no break). When TC is set the serial line will go idle (continuous MARK). Reset sets this bit.

#### RDRF — Receive Data Register Full Flag

This bit is set when the contents of the receiver serial shift register is transferred to the receiver data register.

#### IDLE — Idle Line Detected Flag

This bit is set when a receiver idle line is detected (the receipt of a minimum of ten/eleven consecutive '1's). This bit will not be set by the idle line condition when the RWU bit is set. Once cleared, IDLE will not be set again until after RDRF has been set, (until after the line has been active and becomes idle again).

#### OR — Overrun Error Flag

This bit is set when a new byte is ready to be transferred from the receiver shift register to the receiver data register and the receive data register is already full (RDRF bit is set). Data transfer is inhibited until this bit is cleared.

#### NF — Noise Error Flag

This bit is set if there is noise on a "valid" start bit, any of the data bits, or on the stop bit. The NF bit is set during the same cycle as the RDRF bit but does not get set in the case of an overrun (OR).

#### FE — Framing Error Flag

This bit is set when the word boundaries in the bit stream are not synchronized with the receiver bit counter (generated by the reception of a logic zero bit where a stop bit was expected). The FE bit reflects the status of the byte in the receive data register and the transfer from

## Serial Communications Interface (SCI)

the receive shift register to the receive data register is inhibited in the case of overrun. The FE bit is set during the same cycle as the RDRF bit but does not get set in the case of an overrun (OR). The framing error flag inhibits further transfer of data into the receive data register until it is cleared.

### 11.8.5 Baud Rate Register (BAUD)

The baud rate register (BAUD) is used to set the bit rate for the SCI system. Normally this register is written once, during initialization, to set the baud rate for SCI communications. Both the receiver and the transmitter use the same baud rate which is derived from the MCU bus rate clock. A two stage divider is used to develop custom baud rates from normal MCU crystal frequencies so it is not necessary to use special baud rate crystal frequencies.

\$004B	Bit 7	6	5	4	3	2	1	Bit 0
Read:	0	SPP	SCP1	SCP0	0	SCR2	SCR1	SCR0
Write:	TCLR				RCKB			
Reset:	1	1	0	0	0	U	U	U

**Figure 11-11. SCI Baud Rate Register (BAUD)**

**TCLR** — Clear Baud Rate Counters (for test purposes only)

This bit is disabled and remains low in any mode other than test or bootstrap mode. Reset clears this bit. While in test or bootstrap mode, setting this bit causes the baud rate counter chains to be reset. The logic one state of this bit is transitory and reads always return a logic zero. This control bit is intended only for factory testing of the MCU.

**SPP** — SPI Prescaler bit

- 1 = SCI receiver clock connected to the SPI clock input.
- 0 = bus clock connected to the SPI clock input.

The SCI baud rate can be calculated from the internal bus clock and the two prescaler factors PRS1 and PRS2. The first prescaler factor PRS1 is selected with SCP0 and SCP1, as shown in **Table 11-1**. The

second prescaler factor PRS2 is selected with SCR0, SCR1 and SCR2, as shown in **Table 11-2**. The SCI baud rate B equals the internal bus clock divided by 16 divided by PRS1 divided by PRS2, [B = bus clock: 16: PRS1: PRS2].

SCP1, SCP0 — First Serial Prescaler Select bits

**Table 11-1. First Prescaler Stage**

SCP1	SCP0	PRS1
0	0	1
0	1	3
1	0	4
1	1	13

SCR2, SCR1, SCR0 — SCI Rate Select bits of the second prescaler stage

These three bits select the baud rates for both the transmitter and the receiver.

**Table 11-2. Second Prescaler Stage**

SCR2	SCR1	SCR0	PRS2
0	0	0	1
0	0	1	2
0	1	0	4
0	1	1	8
1	0	0	16
1	0	1	32
1	1	0	64
1	1	1	128

RCKB — SCI Receive Baud Rate Clock Test

This bit is disabled and remains low in any mode other than test or bootstrap modes. Reset clears this bit. While in test or bootstrap mode, this bit may be written but not read (reads always return a logic zero). Setting this bit enables a baud rate counter test mode where

the exclusive-or of the receiver clock (16 times the baud rate) and the transmit clock (1 times the baud rate) is driven out the PC3/TDO pin. This control bit is intended only for factory testing of the MCU.

### 11.9 SCI During WAIT Mode

The SCI system is not affected by the WAIT mode and continues regular operation. Any valid SCI interrupt will wake the system up.



## Section 12. Analog to Digital Converter

### 12.1 Contents

12.2	Introduction . . . . .	144
12.3	A/D Principle . . . . .	144
12.4	A/D Operation . . . . .	145
12.5	Internal and Master Oscillator . . . . .	145
12.6	A/D Registers . . . . .	146
12.6.1	A/D Status and Control Register (ADSCR) . . . . .	146
12.6.2	A/D Data Register . . . . .	148
12.7	A/D During WAIT Mode . . . . .	148
12.8	Analog Input . . . . .	148
12.9	Conversion Accuracy Definitions . . . . .	150
12.9.1	Transfer Curve . . . . .	150
12.9.2	Monotonicity . . . . .	150
12.9.3	Quantization Error . . . . .	151
12.9.4	Offset Error . . . . .	151
12.9.5	Gain Scale Error . . . . .	151
12.9.6	Differential Linearity Error . . . . .	151
12.9.7	Integral Linearity Error . . . . .	151
12.9.8	Total Unadjusted Error . . . . .	151

## 12.2 Introduction

The Analog to Digital converter system consists of a single 8-bit successive approximation converter and a channel multiplexer. There is one 8-bit result data register and one 8-bit status/control register.

The reference supply for the converter uses two dedicated pins rather than being driven by the system power supply lines, because the voltage drops in the bonding wires of such heavily loaded pins would decrease the accuracy of the A/D conversion.

An internal RC type oscillator is activated by the ADRC bit in the A/D status/control register. This RC oscillator is used to give sufficiently high clock rate to the A/D when the bus speed is too low for the A/D to be accurate.

Additionally, the ADON bit allows the user to disconnect the A/D when not used, in order to save power. This is particularly useful to reduce current consumption (by typically 100 $\mu$ A) when going into the WAIT mode.

The A/D is ratiometric and two dedicated pins supply the reference voltage (VREFH and VREFL). An input voltage equal to or greater than VREFH converts to \$FF (full scale) with no overflow indication (if greater). An input voltage equal to VREFL converts to \$00. For ratiometric conversions, the source of each analog input should use VREFH as the supply voltage and be referenced to VREFL.

## 12.3 A/D Principle

The A/D reference inputs are applied to a precision internal digital to analog converter. Control logic drives this D/A and the analog output is successively compared to the selected analog input which was sampled at the beginning of the conversion time. The conversion is monotonic with no missing codes.

The 8-bit conversions are accurate to within  $\pm 1.5$  LSB including quantization.

## 12.4 A/D Operation

The A/D is an 8-bit S.A.R. type A/D converter, with continuous conversion per given channel. The result of a conversion is loaded into the read-only result data register, and a conversion complete flag COCO is set in the A/D status/control register.

Any write to the A/D status/control register will abort the current conversion, reset the conversion complete flag and start a new conversion on the selected channel.

At power-on or external reset, both the ADRC and ADON bits are cleared. Thus the A/D is disabled.

Each channel of conversion takes 32 clock cycles, which must be at a frequency equal to or greater than 1 MHz.

A multiplexer allows the single A/D converter to select one of four external analog signals and three internal reference sources.

## 12.5 Internal and Master Oscillator

If the MCU bus (E clock) frequency is less than 1.0 MHz, an internal RC oscillator (nominally 1.5 MHz) must be used for the A/D conversion clock. This selection is made by setting the ADRC bit in the A/D status/control register to 1.

When the internal RC oscillator is being used as the conversion clock three limitations apply:

1. The conversion complete flag (COCO) must be used to determine when a conversion sequence has been completed, due to the frequency tolerance of the RC oscillator and its asynchronism with regard to the MCU bus clock.
2. The conversion process runs at the nominal 1.5 MHz rate, but the conversion results must be transferred to the MCU result registers synchronously with the MCU bus clock, so the conversion time is limited to a maximum of one channel per bus cycle.
3. If the system clock is running faster than the RC oscillator, the RC oscillator should be turned off, and the system clock used as the conversion clock.

## 12.6 A/D Registers

### 12.6.1 A/D Status and Control Register (ADSCR)

\$004F	Bit 7	6	5	4	3	2	1	Bit 0
Read:	COCO	ADRC	ADON	0	CH3	CH2	CH1	CH0
Write:								
Reset:	0	0	0	0	0	0	0	0

**Figure 12-1. A/D Status and Control Register (ADSCR)**

#### COCO — Conversions Complete

This read-only status bit is set when a conversion is completed, indicating that the A/D data register contains valid results. This bit is cleared whenever the A/D status/control register is written and a new conversion automatically started, or whenever the A/D register is read. Once a conversion has been started by writing to the A/D status/control register, conversions of the selected channel will continue every 32 cycles until the A/D status/control register is written to again. In this continuous conversion mode the A/D data register will be filled with new data, and the COCO bit set, every 32 cycles. Data from the previous conversion will be overwritten regardless of the state of the COCO bit prior to writing.

#### ADRC — RC Oscillator On

When ADRC is set, the A/D section runs on the internal RC oscillator instead of the CPU clock. The RC oscillator requires a time  $t_{RCON}$  to stabilize, and results can be inaccurate during this time. See **Section 12.5 Internal and Master Oscillator**.

#### ADON — A/D On

When the A/D is turned on (ADON = 1), it requires a time  $t_{ADON}$  for the current sources to stabilize, and results can be inaccurate during this time. This bit turns on the charge pump.

**Table 12-1. A/D Clock Selection**

ADRC	ADON	Comments
0	0	RC oscillator off, A/D converter off.
0	1	RC oscillator off, A/D converter on.
1	0	RC oscillator on, A/D converter off. Gives time for the RC osc to stabilize.
1	1	RC oscillator on, A/D converter on. A/D using RC osc clocks

**CH3–0 — Channel Select Bit**

CH3, CH2, CH1 and CH0 form a four bit field which is used to select one of sixteen A/D channels. Channels 4–15 are used for internal reference points. The following table shows the signals selected by the channel select field.

**Table 12-2. A/D Channel Assignments**

CH3	CH2	CH1	CH0	Channel	Signal
0	0	0	0	0	AN0
0	0	0	1	1	AN1
0	0	1	0	2	AN2
0	0	1	1	3	AN3
0	1	0	0	4	V <sub>REFL</sub>
0	1	0	1	5	V <sub>REFL</sub>
0	1	0	0	6	V <sub>REFL</sub>
0	1	1	1	7	V <sub>REFL</sub>
1	0	0	0	8	V <sub>REFH</sub>
1	0	0	1	9	(V <sub>REFH</sub> +V <sub>REFL</sub> )/2
1	0	1	0	10	V <sub>REFL</sub>
1	0	1	1	11	V <sub>REFL</sub>
1	1	X	X	12-15	V <sub>REFL</sub>

**NOTE:** *Performing a digital read of the A/D input with levels other than VDD or VSS on the ADIN pins will result in greater power dissipation during the read cycle, and may give hazardous results on the ADIN input*

## 12.6.2 A/D Data Register

One 8-bit result register is provided. This register is updated each time COCO is set.

\$004E	Bit 7	6	5	4	3	2	1	Bit 0
Read:	bit 7	bit 6	bit 5	bit 4	bit 3	bit 2	bit 1	bit 0
Write:								
Reset:	U	U	U	U	U	U	U	U

**Figure 12-2. A/D Data Register (ADDR)**

## 12.7 A/D During WAIT Mode

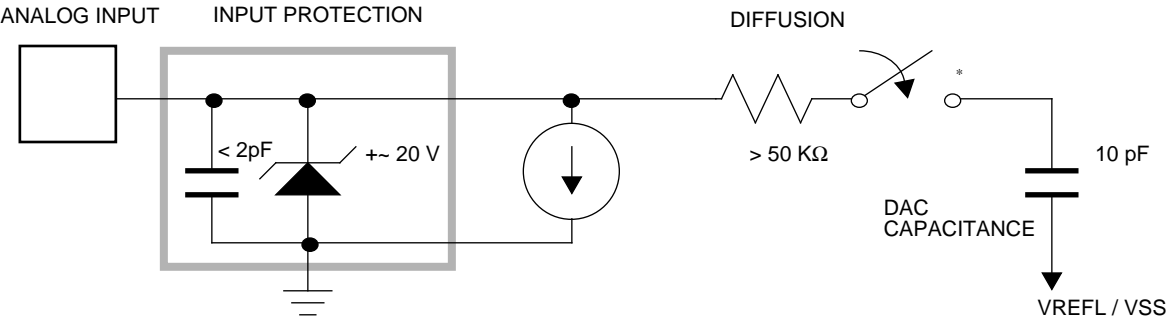
The A/D converter continues normal operation during WAIT mode. To decrease power consumption during WAIT, it is recommended that both the ADON and ADRC bits in the A/D status/control register be cleared if the A/D converter is not being used. If the A/D converter is in use and the system clock rate is above 1.0 MHz, it is recommended that the ADRC bit be cleared.

**NOTE:** *As the A/D converter continues to function normally in WAIT mode, the COCO bit is not cleared.*

## 12.8 Analog Input

The external analog voltage value to be converted by the A/D converter is sampled on an internal capacitor through a resistive path provided by input-selection switches and a sampling aperture time switch. Sampling time is limited to 12 bus clock cycles. After sampling, the analog value is stored on a capacitor and held until the end of conversion. During this hold time, the analog input is disconnected from the internal A/D system and the external voltage source sees a high impedance input.

The equivalent analog input during sampling is a RC low-pass filter with resistance around 50 K $\Omega$  and a capacitance of around 10pF. (It should be noted that these are typical values measured at room temperature).



\* THIS ANALOG SWITCH IS CLOSED ONLY DURING THE 12-CYCLE SAMPLE TIME

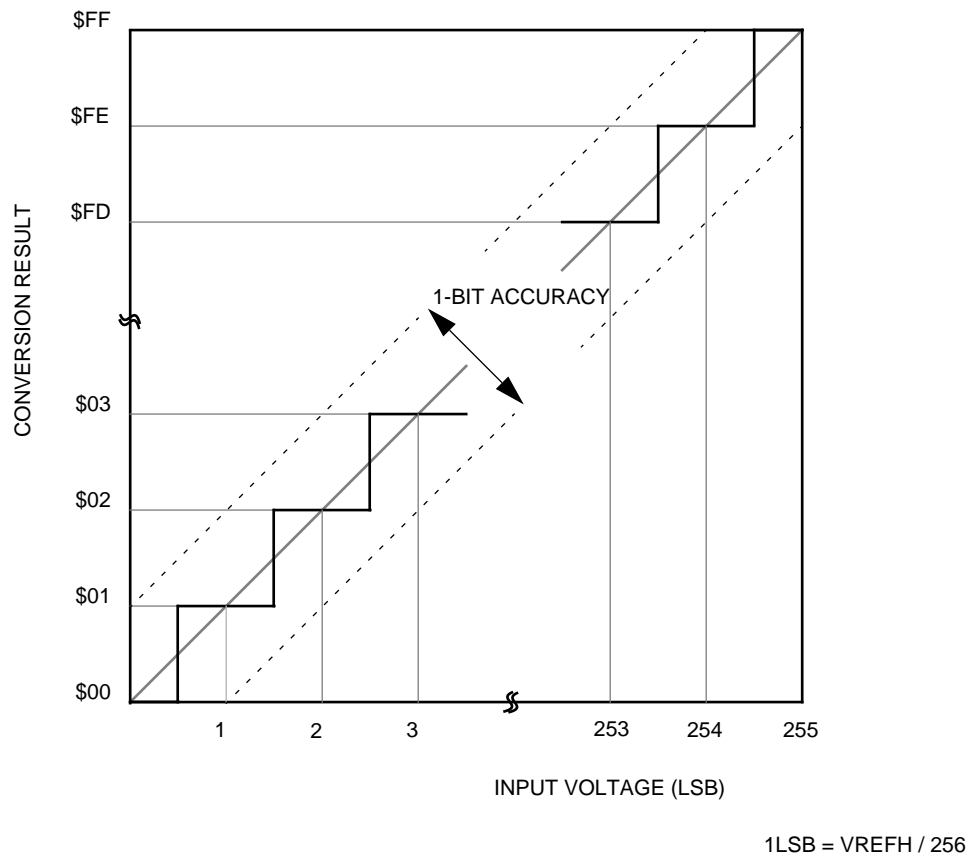
**Figure 12-3. Electrical Model of an A/D Input Pin**

## 12.9 Conversion Accuracy Definitions

This section explains the terminology used to specify the analog characteristics of the A/D converter.

### 12.9.1 Transfer Curve

The ideal transfer curve can be thought of as a staircase of uniform step size with perfect positioning of the endpoints. **Figure 12-4** shows the ideal transfer curve of an 8-bit A/D converter.



**Figure 12-4. Transfer Curve of an Ideal 8-Bit A/D Converter**

### 12.9.2 Monotonicity

The characteristic of the transfer function whereby increasing the input signal results in the output never decreasing.



### 12.9.3 Quantization Error

Also known as digitization error or uncertainty. It is the inherent error involved in digitizing an analog signal due to the finite number of steps at the digital output versus the infinite number of values at the analog input.

### 12.9.4 Offset Error

The offset error is the DC shift of the entire transfer curve of an ideal converter.

### 12.9.5 Gain Scale Error

The gain error is an error in the input to output transfer ratio. Gain error causes an error in the slope of the transfer curve.

### 12.9.6 Differential Linearity Error

The differential linearity error is the difference between actual analog voltage change and the ideal (1LSB) voltage change at any code change.

### 12.9.7 Integral Linearity Error

The integral linearity error is the departure from the best fitting line through all A/D code changes. This error is not specified from the ideal line to make this error independent from offset and gain errors causes an error in the slope of the transfer curve.

### 12.9.8 Total Unadjusted Error

The total unadjusted error is the maximum error that occurs without adjusting offset and gain errors. This error is a combination of offset, scale and integral linearity errors.



## Section 13. EEPROM

### 13.1 Contents

13.2	Introduction . . . . .	153
13.3	EEPROM Control Register (EEPCR) . . . . .	154
13.4	EEPROM Options Register (EEOPR) . . . . .	155
13.5	EEPROM Read, Erase and Programming Procedures . . . . .	156
13.5.1	Read Procedure . . . . .	156
13.5.2	Erase Procedure . . . . .	156
13.5.3	Programming Procedure . . . . .	157
13.6	Operation in WAIT . . . . .	157

### 13.2 Introduction

The EEPROM on this device is 256 bytes and is located from address \$0400 to \$04FF. Programming the EEPROM can be done by the user on a single-byte basis by manipulating the EEPROM control register (EEPCR).

An erased byte reads as 'FF' and any programmed bit reads as '0'.

### 13.3 EEPROM Control Register (EEPCR)

\$001C	Bit 7	6	5	4	3	2	1	Bit 0
Read:	0	0	0	EEOSC	EER1	EER0	EELAT	EEPGM
Write:								
Reset:	0	0	0	0	0	0	0	0

**Figure 13-1. EEPROM Control Register (EEPCR)**

#### EEOSC — EEPROM RC Oscillator Control

When this bit is set, the EEPROM section uses the internal RC oscillator instead of the CPU clock. After setting the EEOSC bit, delay a time  $t_{RCON}$  to allow the RC oscillator to stabilize. This bit is readable and writable and should be set by the user when the internal bus frequency falls below 1.5 MHz. Reset clears this bit.

#### EER1, EER0 — Erase Select Bits

EER1 and EER0 form a 2-bit field which is used to select one of three erase modes: byte, block, or bulk erase. **Table 13-1** shows the modes selected for each bit configuration. These bits are readable and writable and are cleared by reset.

In byte erase mode, only the selected byte is erased.

In block mode, a 128-byte block of EEPROM is erased. The EEPROM memory space is divided into two 128-byte blocks (\$0400–\$047F, \$0480–\$04FF), and doing a block erase to any address within a block will erase the entire block.

In bulk erase mode, the entire 256 byte EEPROM section is erased.

A block protect function is available on block 2 of the EEPROM memory space. See **Section 13.4 EEPROM Options Register (EEOPR)** for more details.

**Table 13-1. Erase Mode Select**

EER1	EER0	MODE
0	0	No Erase
0	1	Byte Erase
1	0	Block Erase (block1 or block2)
1	1	Bulk Erase (block1 & block2)

### EELAT — EEPROM Programming Latch

The EELAT bit is the EEPROM programming latch enable. When EELAT is at 'zero', the EER1, EER0 and EEPGM bits are reset to zero. When the EELAT bit is clear, data can be read from the EEPROM, and when set, this bit allows the address and data to be latched into the EEPROM for further programming or erase operation. Address and data can only be latched when the EEPGM bit is at 'zero'. Reset and power-on reset, reset the EELAT bit.

### EEPGM — EEPROM Programming Power Enable

EEPGM must be written to enable (or disable) the EEPGM function. When set, EEPGM turns on the charge pump and enables the programming (or erasing) power to the EEPROM array. When clear, power is switched off. This enables pulsing of the programming voltage to be controlled internally. This bit can be read at any time, but can only be set if EELAT=1. If EELAT is not set, then EEPGM cannot be set. EELAT=0 or reset clears the EEPGM bit.

## 13.4 EEPROM Options Register (EEOPR)

This register contains the secure and protect functions for the EEPROM and allows the user to select options in a non-volatile manner. The contents of the EEOPR register are loaded into data latches with each power-on or external reset. The register is implemented in EEPROM, therefore reset has no effect on the individual bits.

\$0400	Bit 7	6	5	4	3	2	1	Bit 0
Read:							EEPRT	
Write:								
Reset:	0	0	0	0	0	0	0	0

**Figure 13-2. EEPROM Options Register (EEOPR)**

### EEPRT — EEPROM Protect Bit

In order to achieve a higher degree of protection, the EEPROM is split into two 128-byte blocks. Block 1 cannot be protected. Block 2 is protected by the EEPRT bit of the options register. When this bit is set from 0 to 1 (erased), the protection remains until the next power-on or external reset. EEPRT can only be written to '0' when the ELAT bit in the EEPROM control register is set.

1 = Block 2 of the EEPROM array is not protected; all 256 bytes of EEPROM can be accessed for any read, erase or programming operations

0 = Block 2 of the EEPROM array is protected; any attempt to erase or program a location will be unsuccessful

## 13.5 EEPROM Read, Erase and Programming Procedures

### 13.5.1 Read Procedure

To read data from EEPROM, the EELAT bit must be clear. EEPGM, EER1 and EER0 are all forced to zero. EEPROM is read as if it were a normal ROM. The charge pump generator is off since EEPGM is zero. If a read is performed while ELAT is set, data will be read as \$FF.

### 13.5.2 Erase Procedure

There are three types of ERASE operation mode see **Table 13-1**, byte erase, block erase or bulk erase.

To erase a **byte** of EEPROM: set EELAT = 1, ER1 = 0 and ER0 = 1, write to the address to be erased, and set EEPGM for a time  $t_{\text{EBYTE}}$ .

To erase a **block** of EEPROM: set EELAT = 1, ER1 = 1 and ER0 = 0, write to any address in the block, and set EEPGM for a time  $t_{\text{EBLOC}}$ .

For a **bulk** erase: set EELAT = 1, ER1 = 1, and ER0 = 1, write to an address in the array with A0 or A1 = '1', and set EEPGM for a time  $t_{\text{EBULK}}$ .

### 13.5.3 Programming Procedure

To program the content of EEPROM, set EELAT bits, write data to the desired address, and set the EEPGM bit. After the required programming delay  $t_{\text{EEPGM}}$ , EELAT must be clear, which also resets EEPGM. During a programming operation, any access to EEPROM will return \$FF. To program a second byte, EELAT must be cleared before it is set, or the programming will have no effect.

**NOTE:** *Each byte must be erased before reprogramming. Do not use over-programming (write more 'zeros').*

### 13.6 Operation in WAIT

The user may want to ensure that the RC oscillator is disabled before entering WAIT mode to help conserve power.





## Section 14. Pulse Width Modulator (PWM)

### 14.1 Contents

14.2	Introduction . . . . .	159
14.3	Functional Description . . . . .	160
14.3.1	PWM Channel Microshifting . . . . .	161
14.4	Registers. . . . .	162
14.4.1	PWM Data Registers. . . . .	163
14.4.2	PWM Control Register. . . . .	164
14.4.3	PWM Channel Enable Register. . . . .	165
14.4.4	PWM Channel Polarity Register . . . . .	165
14.5	PWM During WAIT Mode . . . . .	166

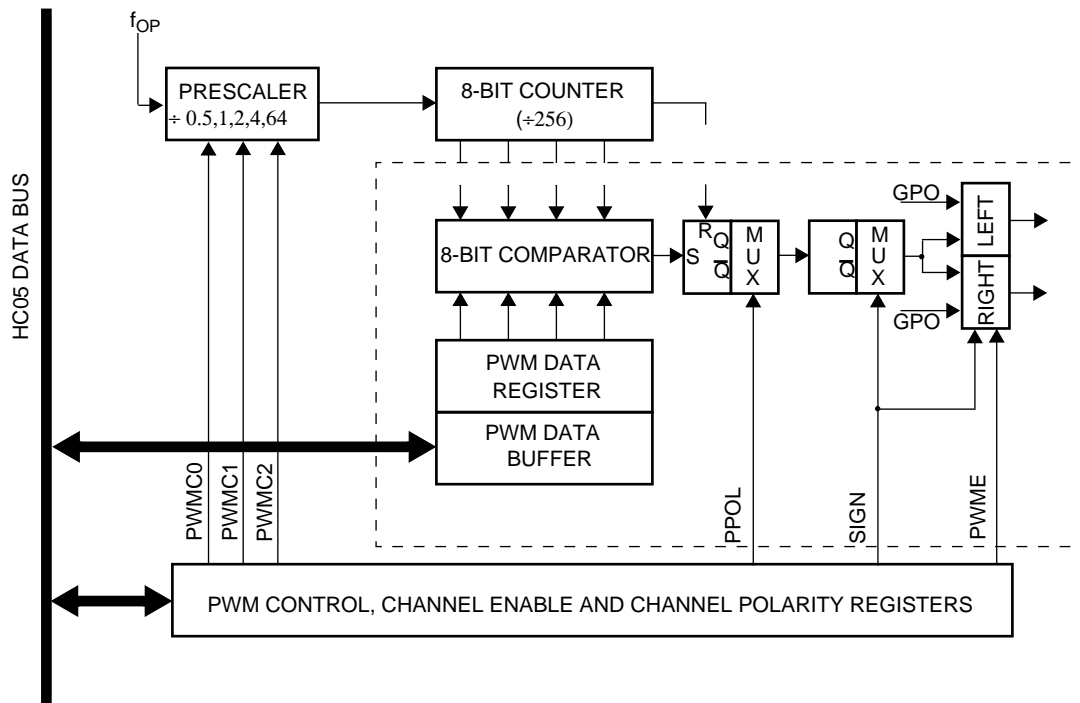
### 14.2 Introduction

The pulse width modulator (PWM) system has eight 8-bit channels. Preceding the 8-bit ( $\div 256$ ) PWM counter is a programmable prescaler. The PWM frequency is selected by choosing the desired divide option from the programmable prescaler.

The four PWM channels 0 to 3 provide four full H-bridge drivers capable of driving air core instruments or stepper motor instruments. Each of the H-bridges will be implemented as a combination of one PWM power driver and another general purpose output (GPO) port power driver. A single PWM channel provides a pulse width ratio for the corresponding PWM driver part of a single H-bridge. Thus the current through the bridge can be controlled by the pulse width ratio.

The four PWM channels 4 to 7 with their power drivers can support four 90° (small angle) aircore instruments.

# Pulse Width Modulator (PWM)



**Figure 14-1. PWM Block Diagram (one channel)**

## 14.3 Functional Description

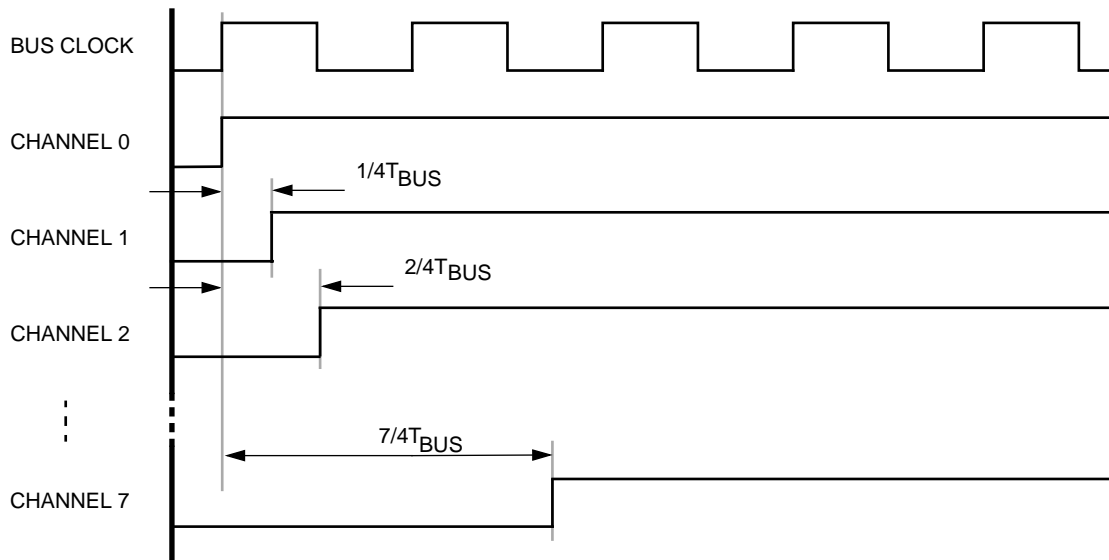
The PWM is capable of generating signals from 0% to 100% duty cycle. A \$00 in the PWM data register yields an 'low' output (0%), but a \$FF yields a duty of 255/256. To achieve the 100% duty ('high' output), the polarity control bit is set to zero while the data register has \$00 in it.

**Figure 14-1** shows the block diagram of a PWM timer channel 0 to 3. The 8-bit counter runs at the rate of the selected clock source provided by the programmable prescaler. The counter is compared to the data register. When the counter matches the data register a flip-flop changes state causing the PWM output to also change state. When the PWM counter rolls over it resets the flip-flop and the output changes back. Notice that there is a select bit called PPOL which allows each channel to independently create a signal which is a low-to-high or high-to-low transition.

The SIGN bit in the PWM control register selects whether the left or the right port line (left or right path of an H-bridge) is enabled for the PWM signal. The opposite port line drives the general purpose output value. The SIGN bit performs also the inversion of the PWM signal. This is done because the duty values are assumed to be 2's complement values in the range from  $-256$  to  $+255$ . A change from duty value  $\$01FF$  to value  $\$0000$  ( $-1$  to  $0$ ) causes a change of the current direction within the corresponding H-bridge. This is done by changing the polarity of the PWM signal and exchanging PWM and output port signals within the H-bridge.

### 14.3.1 PWM Channel Microshifting

Switching more than one PWM channel simultaneously would cause large currents in the corresponding power drivers of the H-bridges. Clocking of different channels must be delayed such that only one channel switches at a time. Therefore microshifts are introduced to achieve a switching delay between different channels.



**Figure 14-2. PWM Microshifts**

The start of the PWM period is shifted by a quarter of the period time of the bus clock  $t_{BUS}$  for the channels 0 to 7. See **Figure 14-2**. Inevitable large currents due to switching of the power drivers are distributed over a number of time slots. They do not load power supply at the same time.

### 14.4 Registers

Associated with the PWM system, there are eight PWM data registers, a control/sign register, a channel enable register and a channel polarity register. The registers can be written to and read at any time.

For updating the PWM values, the following sequence must be followed:

1. Write the corresponding SIGN bit in the PWM control register
2. Write data to the corresponding data register

Not until after the data register is written are the SIGN bits transferred from a buffer to the SIGN register. Data written to a data register is held in a buffer and transferred to the PWM data register at the end of a PWM cycle. Reads of a data register will always result in the read of the PWM data buffer and not the PWM data register.

### 14.4.1 PWM Data Registers

The PWM system has eight 8-bit data registers which hold the duty cycle for each PWM output. The data bits in these registers are set by reset.

		Bit 7	6	5	4	3	2	1	Bit 0
PWM0	Read:	bit 7	bit 6	bit 5	bit 4	bit 3	bit 2	bit 1	bit 0
\$0010	Write:								
PWM1	Read:	bit 7	bit 6	bit 5	bit 4	bit 3	bit 2	bit 1	bit 0
\$0011	Write:								
PWM2	Read:	bit 7	bit 6	bit 5	bit 4	bit 3	bit 2	bit 1	bit 0
\$0012	Write:								
PWM3	Read:	bit 7	bit 6	bit 5	bit 4	bit 3	bit 2	bit 1	bit 0
\$0013	Write:								
PWM4	Read:	bit 7	bit 6	bit 5	bit 4	bit 3	bit 2	bit 1	bit 0
\$0014	Write:								
PWM5	Read:	bit 7	bit 6	bit 5	bit 4	bit 3	bit 2	bit 1	bit 0
\$0015	Write:								
PWM6	Read:	bit 7	bit 6	bit 5	bit 4	bit 3	bit 2	bit 1	bit 0
\$0016	Write:								
PWM7	Read:	bit 7	bit 6	bit 5	bit 4	bit 3	bit 2	bit 1	bit 0
\$0017	Write:								
Reset:		1	1	1	1	1	1	1	1

**Figure 14-3. PWM Data Registers (PWM0–7)**

# Pulse Width Modulator (PWM)

## 14.4.2 PWM Control Register

\$0018	Bit 7	6	5	4	3	2	1	Bit 0
Read:	0	PWMC3	PWMC2	PWMC1	SIGN3	SIGN2	SIGN1	SIGN0
Write:	PWMRST							
Reset:	0	1	1	1	0	0	0	0

**Figure 14-4. PWM Control Register (PWMCTL)**

### PWMRST — PWM Reset

Writing '1' to the PWMRST bit resets the PWM counter. The PWMRST bit reads always as '0'.

### PWMC3–1 — PWM Clock Rate

These bits select the input clock rate and determines the period as shown in **Figure 14-1**. The PWM prescaler clock input is  $f_{OP}$ , which is the bus frequency.

**Table 14-1. PWM Clock Rate**

PWMC3	PWMC2	PWMC1	PWM Clock	PWM OUT
0	0	0	$2 \times f_{OP}$	$f_{OP} / 128$
0	0	1	$f_{OP}$	$f_{OP} / 256$
0	1	0	$f_{OP} / 2$	$f_{OP} / 512$
0	1	1	$f_{OP} / 4$	$f_{OP} / 1024$
1	0	0	$f_{OP} / 64$	$f_{OP} / 16384$
1	0	1	PWM Shut off - to save power if the PWM is not used	
1	1	0		
1	1	1		

### SIGN3–0 — Sign of the PWM Channel 0–3

The SIGN bit selects whether the left or the right output is the PWM signal. The opposite output is the general purpose port. The SIGN bit performs also the inversion of the PWM signal. See **Figure 7-4** for the assignment of the PWM channels to the power driver lines.

1 = Right PWM output

0 = Left PWM output

### 14.4.3 PWM Channel Enable Register

\$0019	Bit 7	6	5	4	3	2	1	Bit 0
Read:	PWME7	PWME6	PWME5	PWME4	PWME3	PWME2	PWME1	PWME0
Write:								
Reset:	0	0	0	0	0	0	0	0

**Figure 14-5. PWM Channel Enable Register (PWMEN)**

#### PWME7–0 — PWM Channel Enable

These bits enable/disable the corresponding PWM channels. If a bit is disabled, the corresponding pin functions as a general purpose output (GPO). Refer to **Section 7.7 Port E and Port F (Power Drivers)**.

1 = The PWM channel is enabled.

0 = The PWM channel is disabled and the corresponding lines are general purpose outputs (GPO)

### 14.4.4 PWM Channel Polarity Register

\$001A	Bit 7	6	5	4	3	2	1	Bit 0
Read:	PPOL7	PPOL6	PPOL5	PPOL4	PPOL3	PPOL2	PPOL1	PPOL0
Write:								
Reset:	0	0	0	0	0	0	0	0

**Figure 14-6. PWM Channel Polarity Register (PWMPOL)**

#### PPOL7–0 — PWM Polarity

These bits initialize the corresponding PWM outputs.

1 = PWM channel is high at the beginning of the period, then toggles to low when the data count is reached.

0 = PWM channel is low at the beginning of the period, then toggles to high when the data count is reached.

### 14.5 PWM During WAIT Mode

The PWM continues normal operation during WAIT mode. To decrease power consumption during WAIT, the PWM should be shut off prior to entering WAIT mode by setting the corresponding bits in the PWM control register. Refer to **Section 7.8 Port E and Port F During WAIT Mode** for information about the corresponding ports.



## Section 15. EPROM

### 15.1 Contents

15.2	Introduction	167
15.3	EPROM Bootloader	167
15.3.1	Bootloader Functions	168
15.4	EPROM Programming	170
15.4.1	EPROM Programming Register (EPROG)	170
15.5	Mask Option Register (MOR)	171

### 15.2 Introduction

The HC705H12 contains 12K EPROM instead of ROM and the mask options are controlled by a programmable nonvolatile mask option register (MOR). The MOR is an EPROM register which must be programmed appropriately prior to operation of the micro-controller.

### 15.3 EPROM Bootloader

Bootloader programming mode is entered upon the rising edge of  $\overline{\text{RESET}}$  if the  $\overline{\text{IRQ}}/V_{\text{PP}}$  pin is at  $V_{\text{TST}}$  and the PB0 pin is at logic one (refer to **Table 6-1**). The bootloader code resides in the ROM from \$3F00 to \$3FEF. This program handles copying of user code from an external EPROM into the on-chip EPROM.

The user code must be a one-to-one correspondence with the internal EPROM addresses (including the MOR).

## 15.3.1 Bootloader Functions

Two pins are used to select various bootloader functions. These pins are PB2 and PB3. Two other pins, PB7 and PB6 are used to drive the PROG LED and the VRF LED respectively. The programming modes are shown in **Table 15-1**.

**Table 15-1. Bootloader Functions**

PB2	PB3	MODE
0	0	Program/Verify EPROM
0	1	Verify only
1	0	Jump to RAM
1	1	Load RAM and Execute

The bootloader uses an external 14 bit counter to address the memory device containing the code to be copied. This counter requires a clock (provided at PB5) and a reset signal (provided at PB4).

**NOTE:** *The EPROM must be erased before performing a program cycle.*

For the communication with a host computer via a standard RS-232 interface PB1 is used as transmitter (TX) and PB0 is used as receiver (RX).

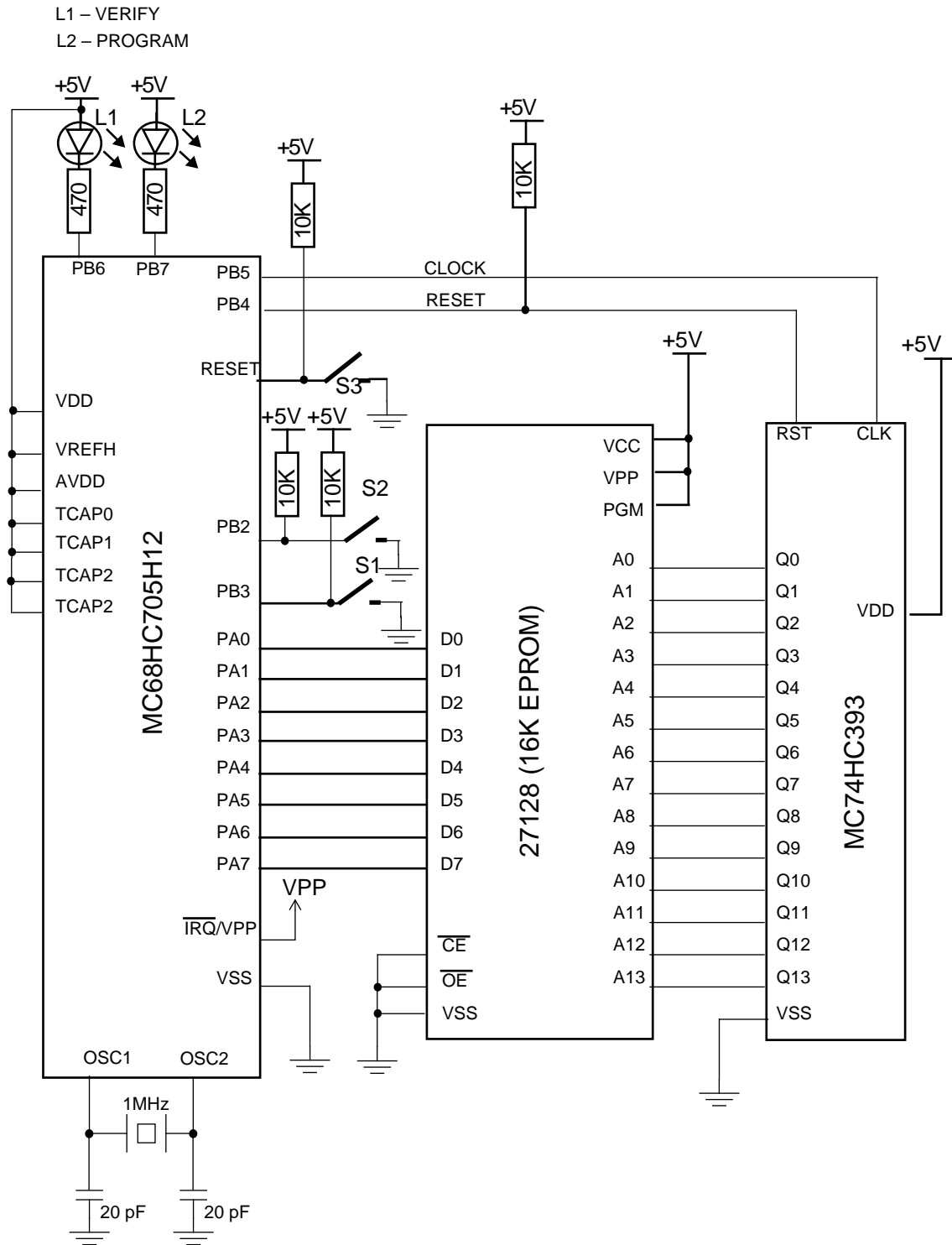
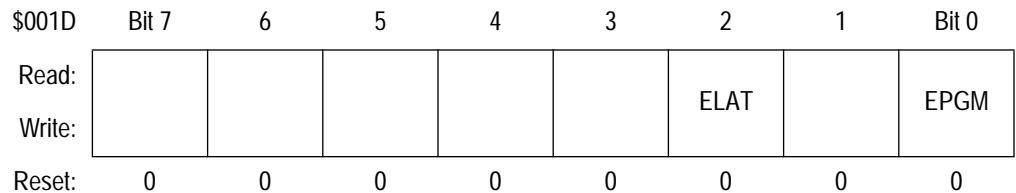


Figure 15-1. MC68HC705H12 Programming Circuit

## 15.4 EPROM Programming

The EPROM array is programmed through manipulation of the programming register located at \$001D. It may be programmed in user, bootstrap or test mode. In addition to the main EPROM array, the mask option register must also be programmed appropriately by the programming software.

### 15.4.1 EPROM Programming Register (EPROG)



**Figure 15-2. EPROM Programming Register (EPROG)**

#### ELAT — EPROM Latch Control

This read/write bit controls the latching of the address and data buses when programming the EPROM.

1 = Address and data buses are latched when the following instruction is a write to one of the EPROM locations. Normal reading is disabled if ELAT = 1

0 = EPROM address and data buses are configured for normal reading

#### EPGM — EPROM Program Control

This read/write bit controls whether the programming voltage is applied to the EPROM array. For programming, this bit can only be set if the LATCH bit has been previously set. Both EPGM and ELAT cannot be set in the single write.

1 = Programming voltage applied to EPROM array

0 = Programming voltage not applied to EPROM array

The sequence for programming the EPROM is as follows:

1. Set the ELAT bit.
2. Write the data to be programmed to the EPROM (or MOR byte) location to be programmed.
3. Set the EPGM bit.
4. Wait a time  $t_{EPGM}$
5. Clear the ELAT and EPGM bits.
6. Repeat for each byte.

## 15.5 Mask Option Register (MOR)

The mask option register (MOR) is used to select all mask options available on the MC68HC705H12. When in the erased state, the EPROM cells read as a logic zero which therefore represents the value transferred from the MOR at reset if it is left unprogrammed. The unimplemented bits of this register are read as '0'.

There are two mask option registers (MOR1, MOR2) implemented. MOR2 is used only.

		Bit 7	6	5	4	3	2	1	Bit 0
MOR1	Read:								
	Write:								
MOR2	Read:								
	Write:	PWDRW							COPE
	Reset:	0	0	0	0	0	0	0	0

**Figure 15-3. Mask Options Registers (MOR1 and MOR2)**

PWDRW — Ports E/F in WAIT mode

1 = Ports E/F continue in WAIT (enabled)

0 = Ports E/F are forced 'low' in WAIT (disabled)

COPE — COP Timer Enable

1 = COP timer enabled.

0 = COP timer disabled.



## Section 16. Electrical Characteristics

### 16.1 Contents

16.2	Maximum Ratings . . . . .	174
16.3	Thermal Characteristics . . . . .	175
16.4	Power Considerations . . . . .	175
16.5	DC Electrical Characteristics . . . . .	176
16.6	Control Timing . . . . .	178
16.7	A/D Converter Characteristics . . . . .	178
16.8	EEPROM Characteristics . . . . .	179
16.9	EPROM Characteristics . . . . .	180
16.10	Power Driver Characteristics . . . . .	180
16.11	Power-on Reset/Low Voltage Reset Characteristics . . . . .	181

## 16.2 Maximum Ratings

(Voltage referenced to  $V_{SS}$ )

Rating	Symbol	Value	Unit
Supply Voltage	$V_{DD}$	-0.3 to +7.0	V
Supply Voltage for Power Drivers	$PV_{DD1,2}$	-0.3 to +10.0	V
Input Voltage Normal Operation	$V_{IN}$	$V_{SS} - 0.3$ to $V_{DD} + 0.3$	V
Monitor Mode ( $\overline{IRQ}$ Pin Only)	$V_{IN}$	$V_{SS} - 0.3$ to $2 \times V_{DD} + 0.3$	V
Current Drain Per Pin	$I_{Omax}$	300	mA
Short Circuit Time for Power Drivers (PE7-0, PF3-0) (note 1)	$t_{SC}$	20	ms
Operating Temperature Range	$T_A$	-40 to +85	°C
Storage Temperature Range	$T_{STG}$	-65 to +150	°C
Write/Erase Cycles EEPROM		10,000	cycles
Data Retention EEPROM		10	years

1. Only one output shorted for a time.

Stresses above those listed as 'maximum ratings' may cause permanent damage to the device. This is a stress rating only and functional operation of the device at these conditions is not implied. Exposure to maximum rating conditions for extended periods may affect device reliability.

This device contains circuitry to protect the inputs against damage due to high static voltages or electric fields; however, it is advised that normal precautions be taken to avoid application of any voltage higher than maximum-rated voltages to this high-impedance circuit. For proper operation, it is recommended that  $V_{IN}$  and  $V_{OUT}$  be constrained to the range  $V_{SS} \leq (V_{IN} \text{ or } V_{OUT}) \leq V_{DD}$ . Unused inputs are connected to the appropriate voltage level, either  $V_{SS}$  or  $V_{DD}$ .

Positive current flow is defined as conventional current flow into the device. Negative current flow is defined as current flow out of the device.



## 16.3 Thermal Characteristics

Characteristic	Symbol	Value	Unit
Thermal Resistance PLCC(52 pin)	$\theta_{JA}$	50	$^{\circ}\text{C/W}$

## 16.4 Power Considerations

The average chip junction temperature,  $T_J$ , in degrees Celsius can be obtained from the following equation:

$$T_J = T_A + (P_D \cdot \theta_{JA}) \quad [1]$$

where:

$T_A$  = Ambient temperature ( $^{\circ}\text{C}$ )

$\theta_{JA}$  = Package thermal resistance, junction-to-ambient ( $^{\circ}\text{C/W}$ )

$P_D = P_{INT} + P_{I/O}$  (W)

$P_{INT}$  = Internal chip power =  $I_{DD} \cdot V_{DD}$  (W)

$P_{I/O}$  = Power dissipation on input and output pins (user determined)

An approximate relationship between  $P_D$  and  $T_J$  (if  $P_{I/O}$  is neglected) is:

$$P_D = \frac{K}{T_J + 273} \quad [2]$$

Solving equations [1] and [2] for K gives:

$$K = P_D \cdot (T_A + 273) + \theta_{JA} \cdot P_D^2 \quad [3]$$

where K is a constant for a particular part. K can be determined by measuring  $P_D$  (at equilibrium) for a known  $T_A$ . Using this value of K, the values of  $P_D$  and  $T_J$  can be obtained for any value of  $T_A$  by solving the above equations. The package thermal characteristics are shown in **Section 16.3 Thermal Characteristics**.

# Electrical Characteristics

## 16.5 DC Electrical Characteristics

( $V_{DD} = 5.0V_{dc} \pm 10\%$ ,  $V_{SS} = 0V_{dc}$ ,  $T_A = -40^\circ C$  to  $+85^\circ C$ , unless otherwise noted)

Characteristic	Symbol	Min	Typ <sup>1</sup>	Max	Unit
Output Voltage $I_{LOAD} = -10 \mu A$ $I_{LOAD} = +10 \mu A$	$V_{OH}$ $V_{OL}$	$V_{DD} - 0.1$ —	— —	— 0.1	V
Output High Voltage $I_{LOAD} = -0.8 \text{ mA}$ PA7-0, PB7-0, PC7-0 $I_{LOAD} = -80 \mu A$ OSC2	$V_{OH}$	$V_{DD} - 0.8$ $V_{DD} - 0.8$	— —	— —	V V
Output Low Voltage $I_{LOAD} = 1.6 \text{ mA}$ PA7-0, PB7-0, PC7-0, $\overline{RESET}$ $I_{LOAD} = 80 \mu A$ OSC2	$V_{OL}$	— —	— —	0.4 0.4	V V
Output Source Current (see maximum ratings) $V_O = 4.5 \text{ V}$ ( $V_{DD} = 5V$ ) $V_O = 4.0 \text{ V}$ ( $V_{DD} = 5V$ ) PA7-0, PB7-0, PC7-0	$I_{OH}$	-1.0 -3.0	— —	-14.5 -26.0	mA mA
Output Sink Current (see maximum ratings) $V_O = 0.5 \text{ V}$ ( $V_{DD} = 5V$ ) $V_O = 1.0 \text{ V}$ ( $V_{DD} = 5V$ ) PA7-0, PB7-0, PC7-0	$I_{OL}$	5.0 10.0	— —	15.0 27.0	mA mA
Input High Voltage PA7-0, PB7-0, PC7-0, PD3-0, $\overline{IRQ}$ , $\overline{RESET}$ , OSC1	$V_{IH}$	$0.7 \times V_{DD}$	—	$V_{DD}$	V
Input Low Voltage PA7-0, PB7-0, PC7-0, PD3-0, $\overline{IRQ}$ , $\overline{RESET}$ , OSC1	$V_{IL}$	$V_{SS}$	—	$0.2 \times V_{DD}$	V
Supply current (note 2) Run ( $f_{OP} = 2.1 \text{ MHz}$ ) Run ( $f_{OP} = 525 \text{ kHz}$ , Slow Mode)	$I_{DD}$ $I_{DD}$	— —	7 —	10 7	mA mA
Wait ( $f_{OP} = 2.1 \text{ MHz}$ ) Wait ( $f_{OP} = 525 \text{ kHz}$ , Slow Mode)	$I_{DD}$ $I_{DD}$	— —	3 1	6 4	mA mA
IO Ports Hi-Z Leakage Current PA7-0, PB7-0, PC7-0	$I_{IL}$	—	—	$\pm 1$	$\mu A$
Input Current PD3-0, $\overline{IRQ}$ , OSC1, $V_{REFH}$	$I_{IN}$	—	—	$\pm 1$	$\mu A$

Characteristic	Symbol	Min	Typ <sup>1</sup>	Max	Unit
Schmitt Trigger Inputs – Hysteresis PA7–0, PB7–5, PC6, PC3–0, $\overline{IRQ}$ , $\overline{RESET}$	$V_{HYRS}$	0.3	—	1.5	V
Internal Pullup Resistor $\overline{RESET}$	$R_{RSTPU}$	8	11	14	K $\Omega$
Injection Current (note 3) PA7–0 PB7–2 PC7–0 PD3–0 PE7–0 PF3–0	$I_{INJ}$	—	—	$\pm 10$ $\pm 10$ $\pm 10$ $\pm 1$ $\pm 10$ $\pm 10$	mA
Data Retention Supply Voltage (note 5)	$V_{DR}$	2			V
Oscillator transconductance ( $I_{OSC2}/V_{OSC1}$ )	$g_m$	1.1	—	—	mA/V

1. Typical values reflect average measurements at midpoint of voltage range at 25 °C.
2. Test Conditions: All I/O Ports are configured as output with no DC load. External Clock Input OSC1 is driven by square wave external clock.
3. A simple protection can be built with a series resistor:  $R > V_{MAX} / I_{INJ}$ . The sum of currents during multiple injection should be limited below the maximum values for a single pin:  $R > (V_{MAX} / I_{INJ}) \cdot (\text{number of pins})$ . The A/D conversion accuracy can degrade to  $\pm 7\text{LSB}$  on a channel adjacent to the one subjected to current injection. Not production tested.
4. The Enabling of the LVR by mask option will cause a permanent current trough the LVR circuitry.
5. The MCU retains RAM contents and CPU register contents.

## 16.6 Control Timing

( $V_{DD} = 5.0V_{dc} \pm 10\%$ ,  $V_{SS} = 0V_{dc}$ ,  $T_A = -40^\circ C$  to  $+85^\circ C$ , unless otherwise noted)

Characteristic	Symbol	Min	Max	Unit
Oscillator Frequency Crystal / Ceramic Resonator External Clock Source	$f_{OSC}$	— dc	4.2 4.2	MHz MHz
Internal Operating Frequency ( $f_{OSC} / 2$ ) Crystal / Ceramic Resonator External Clock	$f_{OP}$	— dc	2.1 2.1	MHz MHz
Cycle Time ( $1 / f_{OP}$ )	$t_{CYC}$	476	—	ns
RESET Pulse Width	$t_{RL}$	1.5	—	$t_{CYC}$
$\overline{IRQ}$ Interrupt Pulse Width Low (Edge-Triggered)	$t_{ILIH}$	120	—	ns
$\overline{IRQ}$ Interrupt Pulse Period	$t_{ILIL}$	— <sup>(1)</sup>	—	$t_{CYC}$
OSC1 Pulse Width	$t_{OH}, t_{OL}$	100	—	ns

1. The minimum period  $t_{ILIL}$  should not be less than the number of cycle times it takes to execute the interrupt service routine plus  $21 t_{CYC}$ .

## 16.7 A/D Converter Characteristics

( $V_{DD} = 5.0V_{dc} \pm 10\%$ ,  $V_{SS} = 0V_{dc}$ ,  $T_A = -40^\circ C$  to  $+85^\circ C$ , unless otherwise noted)

Characteristic	Parameter	Min	Max	Unit
Resolution	Number of bits resolved by the A/D	8	—	Bit
Monotonicity	Conversion result never decreases with an increase in input voltage and has no missing codes	GUARANTEED		
Quantization Error	Uncertainly due to converter resolution	—	$\pm 1/2$	LSB
Offset Error	DC shift of the entire transfer curve of an ideal converter <sup>(1)</sup>	—	$\pm 1/2$	LSB
Gain Error	Difference between the actual and expected gain (end point to end point) <sup>(1)</sup>	—	$\pm 1/2$	LSB
Differential Linearity Error	Difference between the actual analog voltage change and the ideal voltage change <sup>(1)</sup>	—	$\pm 1/2$	LSB
Integral Linearity Error	Max deviation from the best straight line through the A/D transfer characteristics <sup>(1)</sup>	—	$\pm 1/2$	LSB

Characteristic	Parameter	Min	Max	Unit
Absolute Accuracy / Total Unadjusted Error	Difference between the actual input voltage and the full-scale equivalent of the binary code output for all errors <sup>(1)</sup>	—	±1.5	LSB
Conversion Range	Analog input voltage range	V <sub>SS</sub>	V <sub>REFH</sub>	V
V <sub>REFH</sub>	Analog reference voltage <sup>(2)</sup>	V <sub>SS</sub>	VDD + 0.1	V
Conversion Time	Total time to perform a single analog to digital conversion	—	32	cycles
Zero Input Reading	Conversion result when VIN = V <sub>SS</sub>	00	—	Hex
Full Scale Reading <sup>(3)</sup>	Conversion result when VIN = V <sub>REFH</sub>	—	FF	Hex
RC oscillator stabilization time t <sub>RCON</sub>			5	μs
ADC stabilization time t <sub>ADON</sub>			100	μs

1. AVDD = V<sub>REFH</sub> = VDD and V<sub>REFL</sub> = 0 V

2. For 8-bit resolution Vref ≥ 3.5V is necessary

3. When VIN > V<sub>REFH</sub> Conversion result will be 'FF' (for the max input voltage VIN see maximum ratings)

## 16.8 EEPROM Characteristics

(V<sub>DD</sub> = 5.0Vdc±10%, V<sub>SS</sub> = 0Vdc, T<sub>A</sub> = -40°C to +85°C, unless otherwise noted)

Characteristic	Symbol	Min	Max	Unit
EEPROM Byte Programming Time	t <sub>EEPGM</sub>	10	10	ms
EEPROM Byte Erase Time	t <sub>EBYTE</sub>	10	10	ms
EEPROM Block Erase Time	t <sub>EBLOC</sub>	10	50	ms
EEPROM Bulk Erase Time	t <sub>EBULK</sub>	20	50	ms
RC oscillator stabilization time	t <sub>RCON</sub>	—	5	μs

## 16.9 EPROM Characteristics

( $V_{DD} = 5.0V_{dc} \pm 10\%$ ,  $V_{SS} = 0V_{dc}$ ,  $T_A = -40^\circ C$  to  $+85^\circ C$ , unless otherwise noted)

Characteristic	Symbol	Min	Max	Unit
EPROM Programming Voltage Rate <sup>1</sup>	$V_{PP}$	$V_{SS} - 0.3$	17.5	V
EPROM Programming Time	$t_{EPGM}$	4	-	ms
EPROM Data Retention			10	years

1. Typical value = 12 – 15 V.

## 16.10 Power Driver Characteristics

(All voltages are referenced to  $V_{SS}$ ,  $V_{DD} = 5.0V_{dc} \pm 10\%$ ,  $V_{SS} = 0V_{dc}$ ,  $T_A = -40^\circ C$  to  $+85^\circ C$ , inductive load at the Power Drivers Outputs (PE7-0, PF3-0): L=100 mH, R=260 $\Omega$ )

Characteristic	Symbol	Min	Typ	Max	Unit
Operating Supply Voltage for Power Drivers <sup>(1)</sup>	$PV_{DD}$	$V_{DD}$	—	9.5	V
Output High Voltage $I_{OH} = -35$ mA PE7-0, PF3-0	$V_{OH}$	$PV_{DD} - 0.5$	—	$PV_{DD} + 0.5$	V
Output Low Voltage $I_{OL} = +35$ mA PE7-0, PF3-0	$V_{OL}$	0	—	0.5	V
Output Rise Time <sup>(2)</sup> 10% to 90% of $V_{OH}$ , $PV_{DD} = 8V$ , $T = +25^\circ C$ PE7-0, PF3-0	$t_r$	21	—	—	ns
Output Fall Time (note 2) 90% to 10% of $V_{OH}$ , $PV_{DD} = 8V$ , $T = +25^\circ C$ PE7-0, PF3-0	$t_f$	19	—	—	ns

1. The value for the supply voltage for the power driver is under normal operating conditions as well as under short circuit conditions.
2. The power driver outputs are slew rate limited. The value show the minimal time for an inductive load (L=100 mH, R=260 $\Omega$ ) which is connected to  $PV_{DD}$ .

## 16.11 Power-on Reset/Low Voltage Reset Characteristics

( $V_{DD} = 5.0V_{dc} \pm 10\%$ ,  $V_{SS} = 0V_{dc}$ ,  $T_A = -40^{\circ}C$  to  $+85^{\circ}C$ , unless otherwise noted)

Characteristic	Symbol	Min	Typ <sup>(1)</sup>	Max	Unit
Low Voltage Reset (LVR) – Threshold Voltage					
$V_{RON}$ – (VDD Increasing)	$V_{RON}$	3.4	3.85	4.3	V
$V_{ROFF}$ – (VDD Decreasing)	$V_{ROFF}$	3.3	3.75	4.2	V
Hysteresis	$V_{HYST}$	0.1	—	—	V
Minimum Reset Voltage	$V_{min}$	1.0	—	—	V
Supply Voltage Rise and Fall Time	—	—	—	1000	ms
Low Voltage Reset Internal Delay Time	—	—	5	—	ms

1. Typical values reflect average measurements at midpoint of voltage range at 25 °C.





## Section 17. Mechanical Specifications

### 17.1 Contents

17.2 Pin Assignments . . . . .184  
 17.3 Package Dimensions . . . . .184

### 17.2 Pin Assignments

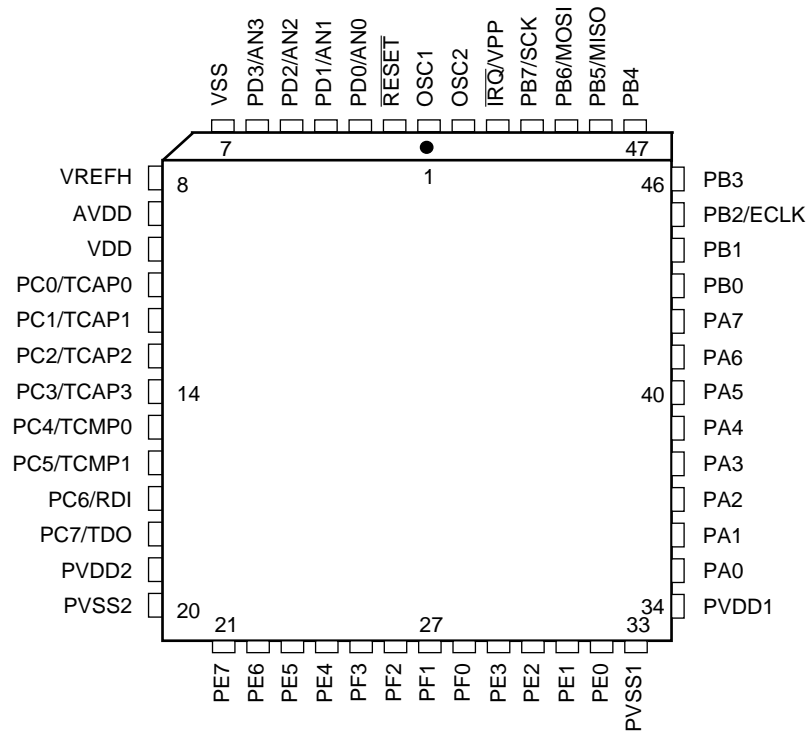


Figure 17-1. 52-Pin PLCC Pin Assignments

# Mechanical Specifications

## 17.3 Package Dimensions

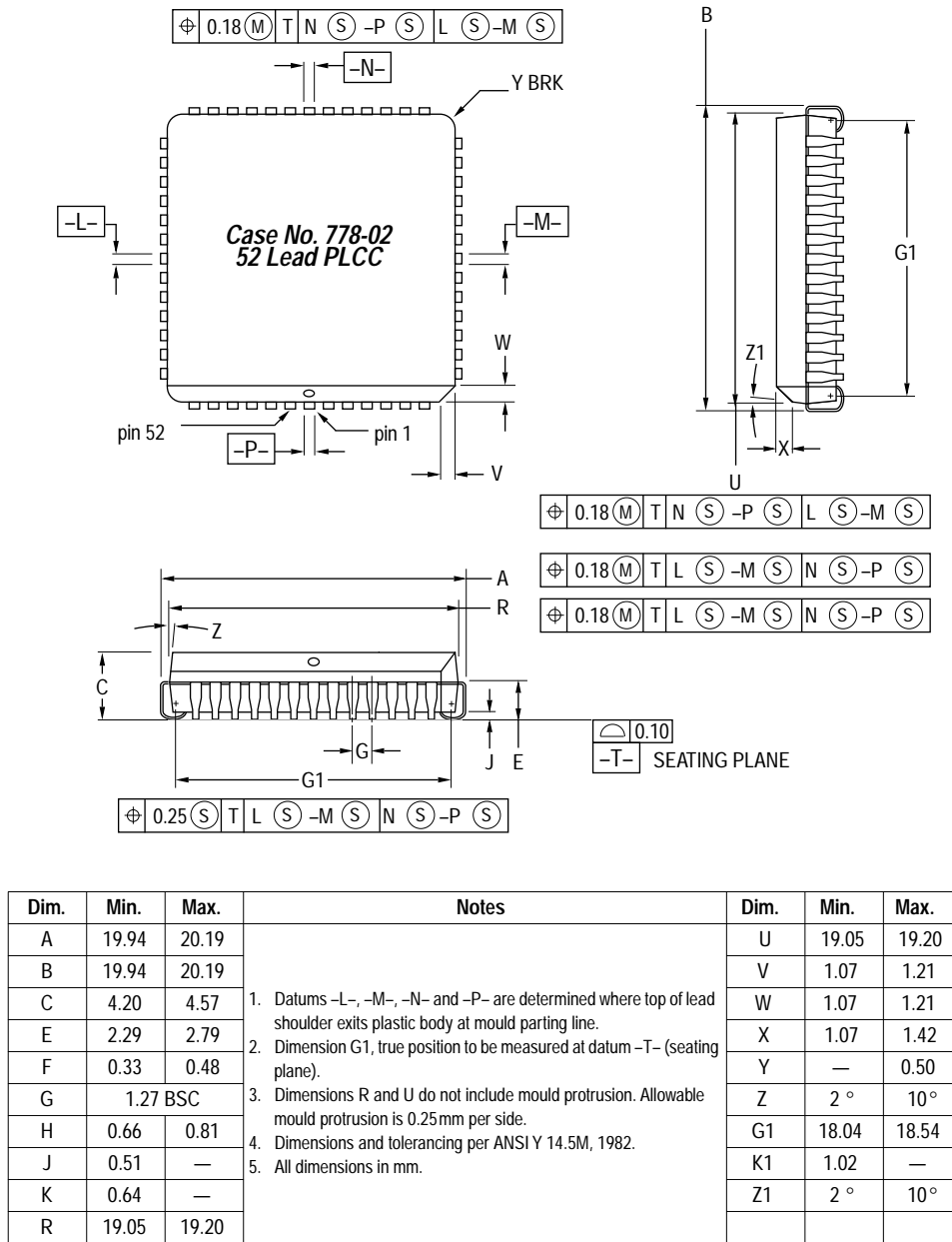


Figure 17-2. 52-Pin PLCC Package Dimensions

- 16-bit timer
  - block diagram [104](#)
  - interrupts [64](#)
  - register addresses [105](#)
- 52-pin PLCC case outline [184](#)
- 52-pin PLCC package [20](#), [183](#)
- 8-bit timer
  - see core timer

## A

### A/D

- channel assignments [147](#)
- clock selection [147](#)
- conversion accuracy [150](#)
- data register (ADDR) [148](#)
- electrical characteristics [178](#)
- errors [151](#)
- status and control register (ADSCR) [146](#), [147](#)

- accumulator [39](#)
- address mark wake-up [131](#)
- addressing modes [42](#)
- ADON bit in ADSCR [146](#)
- ADRC bit in ADSCR [146](#)
- ALU — arithmetic/logic unit [42](#)
- AN0–AN3 [23](#)
- analog input [148](#)
- analog to digital converter
  - see A/D
- AVDD [21](#)

## B

- bit manipulation instructions [50](#)
- block diagrams
  - 16-bit timer [104](#)
  - core timer [98](#)
  - MC68HC(7)05H12 [19](#)
  - PWM [160](#)
  - SCI [128](#)
  - SPI [119](#)
- bootloader [167](#)

## C

- carry/borrow flag [41](#)
- C-bit in CCR [41](#)
- CH3\_0 bits in ADSCR [147](#)
- channel microshifting [161](#)
- CO2E bit in TCR2 [112](#)
- COCO bit in ADSCR [146](#)
- COIE bit in TCR1 [111](#)
- condition code register (CCR) [40](#)
- control instructions [51](#)
- control timing [178](#)
- COP
  - register (COPR) [72](#)
  - reset [70](#), [101](#)
- COPE bit in MOR [171](#)
- COPR bit in COPR [72](#)
- core timer
  - block diagram [98](#)
  - counter register (CTCR) [101](#)
  - interrupts [64](#)

- status and control register (CTSCR) 99
- counter 105
- CPHA bit in SPCR 122
- CPOL bit in SPCR 122
- cross coupled coils 85

## D

- data retention mode 78
- DC electrical characteristics 176
- differential linearity error 151
- direct addressing mode 43
- DOD bit in SPCR 121

## E

- ECLK bit in SYSCR 34
- ECLK pin 22
- EDGE7–0 bits in PAIED 81
- EELAT bit in EEPCCR 155
- EEOSC bit in EEPCCR 154
- EEPGM bit in EEPCCR 155
- EEPROM 35
  - control register (EEPCCR) 154, 155
  - electrical characteristics 179
  - erase 156
  - options register (EEOPR) 155, 156
  - programming 157
  - read 156
- EEPRT bit in EEOPR 156
- EER1, EER0 bits in EEPCCR 154
- ELAT bit in EPROG 170
- EPGM bit in EPROG 170
- EPROM 35
  - bootloader 167
  - electrical characteristics 180
  - programming 170
  - programming register (EPROG) 170
- erase mode select 154

- extended addressing mode 43
- external interrupt 63

## F

- FE bit in SCSR 139
- features 18
- flowcharts
  - interrupt 62
  - WAIT 77

## G

- gain scale error 151

## H

- half-carry flag 41
- hardware interrupts 63–65
- H-bit in CCR 41
- H-bridge
  - driver 86
  - states 90
  - with the PWM 94

## I

- I/O programming 95
- IC1F bit in TSR 113
- IC2F bit in TSR 113
- ICI1E bit in TCR1 111
- ICI2E bit in TCR1 111
- IDLE bit in SCSR 139
- idle line wake-up 131
- IEDG1 bit in TCR1 111
- IEDG2 bit in TCR1 111
- ILIE bit in SCCR2 137
- illegal address reset 72
- immediate addressing mode 43
- index register 39
- indexed addressing mode 44

inherent addressing mode [43](#)  
input capture  
  register 1 [108](#)  
  register 2 [109](#)  
instruction types [45](#)  
integral linearity error [151](#)  
interrupts  
  16-bit timers [64](#)  
  core timer [64](#)  
  flowchart [62](#)  
  hardware [63](#)  
  IRQ [63](#)  
  keyboard [63](#)  
  SCI [65](#)  
  SPI [65](#)  
  SWI [63](#)  
IRQ bit in SYSCR [34](#)  
 $\overline{\text{IRQ}}$  pin [21](#)

## J

jump/branch instructions [48](#)  
junction temperature, chip [175](#)

## K

keyboard interrupt [22](#), [63](#), [80](#)

## L

low power modes [65](#), [76](#)  
low voltage reset (LVR) [72](#)  
  electrical characteristics [181](#)

## M

M bit in SCCR1 [136](#)  
mask options [20](#)  
  register (MOR) [171](#)  
master mode [120](#)

maximum ratings [174](#)  
memory map [26](#)  
MISO [22](#), [116](#)  
modes of operation  
  data retention [78](#)  
  entry conditions [75](#)  
  low power (WAIT) [65](#), [76–78](#)  
  monitor [76](#)  
  slow [78](#)  
  user [75](#)  
monitor mode [76](#)  
monitor ROM [35](#)  
monotonicity [150](#)  
MOR [171](#)  
MOSI [22](#), [117](#)  
MSTR bit in SPCR [121](#)

## N

N-bit in CCR [41](#)  
negative flag [41](#)  
NF bit in SCSR [139](#)

## O

OC1F bit in TSR [113](#)  
OC2F bit in TSR [114](#)  
OCI1E bit in TCR1 [111](#)  
OCI2E bit in TCR2 [112](#)  
offset error [151](#)  
OLVL1 bit in TCR1 [111](#)  
OLVL2 bit in TCR2 [112](#)  
opcode map [58](#)  
operating modes  
  see modes of operation  
OR bit in SCSR [139](#)  
OSC1, OSC2 [21](#)  
oscillator pins [21](#)  
output compare [106](#)

register 1 106  
 register 2 107

## P

PA0–PA7 22  
 PAIE7–0 bits in PAICR 81  
 PAIF7–0 bits in PAISR 82  
 PB0–PB7 22  
 PC0–PC7 22  
 PD0–PD3 23  
 PE0–PE7 23  
 PF0–PF3 23  
 pins  
   AN0–AN3 23  
   assignments 20  
   AVDD 21  
   ECLK 22  
    $\overline{\text{IRQ}}$  21  
   keyboard interrupt 22  
   MISO 22  
   MOSI 22  
   OSC1, OSC2 21  
   port A (PA0–PA7) 22  
   port B (PB0–PB7) 22  
   port C (PC0–PC7) 22  
   port D (PD0–PD3) 23  
   port E (PE0–PE7) 23  
   port F (PF0–PF3) 23  
   PVDD1, PVSS1, PVDD2, PVSS2 23  
   RDI 22  
    $\overline{\text{RESET}}$  21  
   SCK 22  
   TCAPO–3 22  
   TCMP0–1 22  
   TDO 22  
   VDD, VSS 21  
   VPP 21  
   VREFH 23

port A  
   interrupt control register (PAICR) 81  
   interrupt edge register (PAIED) 81  
   interrupt status register (PAISR) 82  
   keyboard interrupt 80  
 port B 82  
 port C 83  
 port D 83  
 port E and port F  
   configurations 92  
   mismatch registers (PEMISM and PFMISM)  
     89, 90  
   power drivers 83  
 power considerations 175  
 power driver  
   circuit 87  
   electrical characteristics 180  
   pins 23, 83  
 power supply pins 21  
 power-on reset (POR) 70  
   electrical characteristics 181  
 PPOL7–0 bits in PWMPOL 165  
 program counter 40  
 programming circuit 169  
 programming model 38  
 pulse width modulator  
   see PWM  
 PVDD1, PVSS1, PVDD2, PVSS2 23  
 PWDRW bit in MOR 171  
 PWM  
   block diagram 160  
   channel enable register (PWME7–0) 165  
   channel microshifting 161  
   channel polarity register (PWMPOL) 165  
   control register (PWMCTL) 164  
   data registers (PWM0–7) 163  
 PWM0–7 bits in PWMCTL 164  
 PWME7–0 bits in PWME7–0 165

PWMRST bit in PWMCTL 164

## Q

quantization error 151

## R

R8 bit in SCCRI 136

RAM 35

RCKB bit in BAUD 141

RDI 22

RDRF bit in SCSR 139

RE bit in SCCR2 138

read-modify-write instructions 47

receive data (RDI) 132

receiver 130

register/memory instructions 46

registers

  ADDR 148

  ADSCR 146

  BAUD 140

  complete listing 29–33

  COPR 72

  CTCR 102

  CTSCR 99

  EEOPR 155

  EEPCCR 154

  EPROG 170

  MOR 171

  PAICR 81

  PAIED 81

  PAISR 82

  PEMISM 89

  PFMISM 90

  PWM07 163

  PWMCTL 164

  PWMEN 165

  PWMPOL 165

  SCCR1 136

  SCCR2 137

  SCDAT 135

  SCSR 138

  SPCR 121

  SPDAT 124

  SPSR 123

  summary 27

  SYSCR 34

  TCR1 110

  TCR2 112

  TSR 113

relative addressing mode 45

$\overline{\text{RESET}}$  21, 67

resets

  computer operating properly (COPR) 70

  external 67

  illegal address 72

  internal 68

  LVR 72

  POR 70

$\overline{\text{RESET}}$  67

RIE bit in SCCR2 137

ROM 35

RRTIF bit in CTSCR 100

RT1, RT0 bits in CTSCR 100

RTI rates 100

RTIE bit in CTSCR 100

RTIF bit in CTSCR 99

RTOF bit in CTSCR 100

RWU bit in SCCR2 138

## S

SBK bit in SCCR2 138

SC bit in SYSCR 34

SCI

  baud rate register (BAUD) 140, 141

  block diagram 128

- control register 1 (SCCR1) 136
- control register 2 (SCCR2) 137, 138
- data format 130
- data register (SCDAT) 135
- interrupt 65
- receiver wake-up 130
- status register (SCSR) 138, 139
- SCK 22, 117
- SCP1, SCPO bits in BAUD 141
- SCR2, SCR1, SCRO bits in BAUD 141
- serial communications interface
  - see SCI
- serial peripheral interface
  - see SPI
- short circuit detection 88
- SIGN3–0 bits in PWMCTL 164
- slave mode 120
- slow mode 78
- software interrupt (SWI) 63
- SPE bit in SPCR 121
- SPI
  - block diagram 119
  - control register (SPCR) 121, 122
  - data I/O register (SPDAT) 124
  - interrupt 65
  - master and slave 120
  - MISO 116
  - MOSI 117
  - serial clock (SCK) 117
  - status register (SPSR) 123
- SPIE bit in SPCR 121
- SPIF bit in SPSR 123
- SPP bit in BAUD 140
- SPR1, SPR0 bits in SPCR 122
- stack pointer 39
- start bit 132
- system control register (SYSCR) 34
  - ECLK — internal system clock available 34

- IRQ — IRQ sensitivity 34
- SC — system clock option 34

## T

- T8 bit in SCCR1 136
- TC bit in SCSR 139
- TCAP0–3 22
- TCAP1 bit in TSR 113
- TCAP2 bit in TSR 113
- TCIE bit in SCCR2 137
- TCLR bit in BAUD 140
- TCMP0–1 22
- TDO 22
- TDRE bit in SCSR 139
- TE bit in SCCR2 137
- thermal characteristics 175
- TIE bit in SCCR2 137
- timer control register 1 (TCR1) 110
  - CO1E — timer compare 1 output enable 111
  - IC11E — input capture 1 interrupt enable 111
  - IC12E — input capture 2 interrupt enable 111
  - IEDG1 — input edge 111
  - IEDG2 — input edge 111
  - OC11E — output compare 1 interrupt enable 111
  - OLVL1 — output level 1 111
  - TOIE — timer overflow interrupt enable 111
- timer control register 2 (TCR2) 112
  - CO2E — timer compare 2 output enable 112
  - OC12E — output compare 2 interrupt enable 112
  - OLVL2 — output level 2 112
- timer status register (TSR) 113
  - IC1F — input capture 1 flag 113
  - IC1F — output compare 1 flag 113
  - IC2F — input capture 2 flag 113
  - IC2F — output compare 2 flag 114
  - TCAP1 — timer capture 1 113



TCAP2 — timer capture 2 [113](#)

TOF — timer overflow flag [113](#)

timing diagrams

data clock [118](#)

$\overline{\text{RESET}}$  and POR [69](#)

TOF bit in CTSCR [99](#)

TOF bit in TSR [113](#)

TOFE bit in CTSCR [100](#)

TOIE bit in TCR1 [111](#)

total unadjusted error [151](#)

transfer curve [150](#)

transmit data (TDO) [135](#)

## U

user mode [75](#)

## V

VDD, VSS [21](#)

vector addresses [61](#)

VPP [21](#)

VREFH [23](#)

## W

WAIT mode [65](#), [77](#)

WAKE bit in SCCR1 [136](#)

wake-up [130](#)

address mark [131](#)

idle line [131](#)

watchdog

see COP

WCOL bit in SPSR [123](#)


## Z

Z-bit in CCR [41](#)

zero flag [41](#)





Motorola reserves the right to make changes without further notice to any products herein. Motorola makes no warranty, representation or guarantee regarding the suitability of its products for any particular purpose, nor does Motorola assume any liability arising out of the application or use of any product or circuit, and specifically disclaims any and all liability, including without limitation consequential or incidental damages. "Typical" parameters which may be provided in Motorola data sheets and/or specifications can and do vary in different applications and actual performance may vary over time. All operating parameters, including "Typicals" must be validated for each customer application by customer's technical experts. Motorola does not convey any license under its patent rights nor the rights of others. Motorola products are not designed, intended, or authorized for use as components in systems intended for surgical implant into the body, or other applications intended to support or sustain life, or for any other application in which the failure of the Motorola product could create a situation where personal injury or death may occur. Should Buyer purchase or use Motorola products for any such unintended or unauthorized application, Buyer shall indemnify and hold Motorola and its officers, employees, subsidiaries, affiliates, and distributors harmless against all claims, costs, damages, and expenses, and reasonable attorney fees arising out of, directly or indirectly, any claim of personal injury or death associated with such unintended or unauthorized use, even if such claim alleges that Motorola was negligent regarding the design or manufacture of the part. Motorola and  are registered trademarks of Motorola, Inc. Motorola, Inc. is an Equal Opportunity/Affirmative Action Employer.

**How to reach us:**

**USA/EUROPE/Locations Not Listed:** Motorola Literature Distribution; P.O. Box 5405; Denver, Colorado 80217.1-800-441-2447 or 303-675-2140

**Mfax™:** RMFAX0@email.sps.mot.com – TOUCHTONE 602-244-6609

**INTERNET:** <http://www.mot.com/SPS/>

**JAPAN:** Nippon Motorola Ltd.; Tatsumi-SPD-JLDC, 6F Seibu-Butsuryu-Center, 3-14-2 Tatsumi Koto-Ku, Tokyo 135, Japan. 81-3-3521-8315

**ASIA/PACIFIC:** Motorola Semiconductors H.K. Ltd.; 8B Tai Ping Industrial Park, 51 Ting Kok Road, Tai Po, N.T., Hong Kong. 852-26629298

Mfax is a trademark of Motorola, Inc.



**MOTOROLA**

© Motorola, Inc., 1997

**HC05H12GRS/D**